

EPSON

6-Axis Robots

C4 series

MANIPULATOR MANUAL

Rev.20

EM208R4411F

6-Axis Robots

C4 series Manipulator Manual

Rev.20

FOREWORD

Thank you for purchasing our robot products.

This manual contains the information necessary for the correct use of the manipulator.

Please carefully read this manual and other related manuals before installing the robot system.

Keep this manual handy for easy access at all times.

WARRANTY

The robot and its optional parts are shipped to our customers only after being subjected to the strictest quality controls, tests, and inspections to certify its compliance with our high performance standards.

Product malfunctions resulting from normal handling or operation will be repaired free of charge during the normal warranty period. (Please contact the supplier of your region for warranty period information.)

However, customers will be charged for repairs in the following cases (even if they occur during the warranty period):

1. Damage or malfunction caused by improper use which is not described in the manual, or careless use.
2. Malfunctions caused by customers' unauthorized disassembly.
3. Damage due to improper adjustments or unauthorized repair attempts.
4. Damage caused by natural disasters such as earthquake, flood, etc.

Warnings, Cautions, Usage:

1. If the robot or associated equipment is used outside of the usage conditions and product specifications described in the manuals, this warranty is void.
2. If you do not follow the WARNINGS and CAUTIONS in this manual, we cannot be responsible for any malfunction or accident, even if the result is injury or death.
3. We cannot foresee all possible dangers and consequences. Therefore, this manual cannot warn the user of all possible hazards.

TRADEMARKS

Microsoft, Windows, and Windows logo are either registered trademarks or trademarks of Microsoft Corporation in the United States and/or other countries. Other brand and product names are trademarks or registered trademarks of the respective holders.

NOTICE

No part of this manual may be copied or reproduced without authorization.

The contents of this manual are subject to change without notice.

Please notify us if you should find any errors in this manual or if you have any comments regarding its contents.

MANUFACTURER

SEIKO EPSON CORPORATION

CONTACT INFORMATION

Contact information is described in “SUPPLIERS” in the first pages of the following manual:

Robot System Safety and Installation Read this manual first

Regarding battery disposal



The crossed out wheeled bin label that can be found on your product indicates that this product and incorporated batteries should not be disposed of via the normal household waste stream. To prevent possible harm to the environment or human health please separate this product and its batteries from other waste streams to ensure that it can be recycled in an environmentally sound manner. For more details on available collection facilities please contact your local government office or the retailer where you purchased this product. Use of the chemical symbols Pb, Cd or Hg indicates if these metals are used in the battery.

This information only applies to customers in the European Union, according to DIRECTIVE 2006/66/EC OF THE EUROPEAN PARLIAMENT AND OF THE COUNCIL OF 6 September 2006 on batteries and accumulators and waste batteries and accumulators and repealing Directive 91/157/EEC and legislation transposing and implementing it into the various national legal systems.

For other countries, please contact your local government to investigate the possibility of recycling your product.

The battery removal/replacement procedure is described in the following manuals:

Robot Controller manual / Manipulator manual (Maintenance section)

Before Reading This Manual

This section describes what you should know before reading this manual.

Structure of Control System

C4 Manipulators can be used with the following combinations of Controllers and software.

Controller : RC700, RC700-A

Software : EPSON RC+ 7.0

Setting by Software

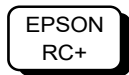

This manual contains setup procedures using the software.

Those sections are indicated by the symbol on the left.

Turning ON/OFF Controller

When you see the instruction “Turn ON/OFF the Controller” in this manual, be sure to turn ON/OFF all the hardware components.

Photos and Illustrations Used in This Manual

The appearance of some parts may differ from those on an actual product depending on when it was shipped or the specifications. The procedures themselves, however, are accurate.

Setup & Operation

1. Safety	3
1.1 Conventions.....	3
1.2 Design and Installation Safety.....	3
1.3 Operation Safety	4
1.4 Emergency Stop.....	6
1.5 How to Move Arms with the Electromagnetic Brake.....	8
1.5.1 Moving the Arm using the brake release unit.....	9
1.5.2 Moving the Arm using the software.....	9
1.6 Precaution for Operation in Low Power Status.....	9
1.7 Warning Labels.....	10
2. Specifications	12
2.1 Features of Manipulators	12
2.2 Model Number.....	13
2.3 Part Names and Motion Range of Each Arm.....	14
2.4 Outer Dimensions.....	15
2.4.1 C4-A601**	15
2.4.2 C4-A901**.....	16
2.5 Standard Motion Range	17
2.5.1 C4-A601**.....	17
2.5.2 C4-A901**	18
2.6 Specifications	20
2.6.1 Specifications table	20
2.6.2 Option	22
2.7 How to Set the Model.....	23
3. Environment and Installation	24
3.1 Environmental Conditions	24
3.2 Unpacking, Transportation, and Relocation.....	25
3.3 Mounting Dimensions.....	29
3.4 Installation	30
3.5 Connecting the Cables.....	33
3.6 User Wires and Pneumatic Tubes.....	34
3.7 Checking the Basic orientation.....	35
4. End Effectors	36
4.1 Attaching an End Effector.....	36
4.2 Attaching Camera and Air Valves.....	37
4.3 WEIGHT and INERTIA Settings.....	39
4.3.1 WEIGHT setting.....	41
4.3.2 INERTIA setting.....	46
4.4 Precautions for Auto Acceleration/Deceleration.....	50

5. Motion Range	51
5.1 Motion Range Setting by Pulse Range (for All Arms).....	52
5.1.1 Max. Pulse Range of Arm #1	53
5.1.2 Max. Pulse Range of Arm #2	54
5.1.3 Max. Pulse Range of Arm #3	54
5.1.4 Max. Pulse Range of Arm #4	55
5.1.5 Max. Pulse Range of Arm #5	56
5.1.6 Max. Pulse Range of Arm #6	56
5.2 Motion Range Setting by Mechanical Stops.....	57
5.2.1 Motion Range Setting of Arm #1	57
5.2.2 Motion Range Setting of Arm #2.....	58
5.2.3 Motion Range Setting of Arm #3.....	58
5.3 Restriction of Manipulator Operation by Joint Angle Combination	59
5.4 Coordinate System.....	61
5.5 Changing the Robot.....	62
5.6 Setting the Cartesian (Rectangular) Range in the XY Coordinate System of the Manipulator	63
6. Options	64
6.1 Brake Release Unit	64
6.2 Camera Plate Unit.....	67
6.3 PS Compatible Plate (Tool Adapter)	70
6.4 Base Side Angled Fittings	72
6.5 Base Side Fittings	74
6.6 PS Compatible Plate (Base Adapter).....	77
6.7 Adjustable Mechanical Stop (Joint #2: only C4-A901**)	78

Maintenance

1. Safety Maintenance	81
2. General Maintenance	83
2.1 Maintenance Inspection	83
2.1.1 Schedule for Maintenance Inspection.....	83
2.1.2 Inspection Point.....	84
2.2 Overhaul (Parts Replacement)	86
2.3 Greasing.....	88
2.4 Tightening Hexagon Socket Head Bolts	90
2.5 Layout of Maintenance Parts	91
3. Covers	92
3.1 Arm #1 Top Cover	93
3.2 Arm #1 Side Cover.....	93
3.3 Arm #2 Side Cover.....	94
3.4 Arm #3 Head Cover	94
3.5 Arm #3 Bottom Cover.....	95

3.6	Arm #4 side cover	95
3.7	Base Bottom Cover	96
3.8	Connector Plate.....	96
3.9	Connector Sub Plate	97
3.10	User Plate.....	97
4.	Cable Unit	98
4.1	Replacing the Cable Unit	98
4.2	Connector Pin Assignments	125
4.2.1	Signal Cable	125
4.2.2	Power Cable	131
4.2.3	User Cable.....	134
4.2.4	Color of Cables.....	134
5.	Joint #1	135
5.1	Joint #1 - Replacing the Motor	136
5.2	Joint #1 - Replacing the Reduction Gear Unit	140
5.3	Joint #1 - Replacing the Timing Belt	148
5.4	Joint #1 - Replacing the Electromagnetic Brake.....	149
6.	Joint #2	150
6.1	Joint #2 - Replacing the Motor	151
6.2	Joint #2- Replacing the Reduction Gear Unit	156
6.3	Joint #2 - Replacing the Timing Belt	164
6.4	Joint #2 - Replacing the Electromagnetic Brake.....	165
7.	Joint #3	166
7.1	Joint #3 - Replacing the Motor (with a Brake).....	167
7.2	Joint #3 - Replacing the Reduction Gear Unit	171
7.3	Joint #3 - Replacing the Timing Belt	179
8.	Joint #4	180
8.1	Joint #4 - Replacing the Motor	181
8.2	Joint #4 - Replacing the Reduction Gear Unit	186
8.3	Joint #4 - Replacing the Timing Belt	193
8.4	Joint #4 - Replacing the Electromagnetic Brake.....	194
9.	Joint #5	195
9.1	Joint #5 - Replacing the Motor	196
9.2	Joint #5 - Replacing the Reduction Gear Unit	200
9.3	Joint #5 - Replacing the Timing Belt	210
9.4	Joint #5 - Replacing the Electromagnetic Brake.....	211

10. Joint #6	212
10.1 Joint #6 - Replacing the Motor	213
10.2 Joint #6 - Replacing the Reduction Gear Unit	217
10.3 Joint #6 - Replacing the Timing Belt	222
10.4 Joint #6 - Replacing the Electromagnetic Brake.....	223
11. Replacing the Arm #5 O-ring	224
Removal: Arm #5 O-ring	224
Installation: Arm #5 O-ring	224
12. Replacing the Battery Unit	225
12.1 Replacing the Battery Unit (Lithium Battery)	227
12.2 Replacing the Battery Board.....	229
13. Replacing the Control Board	231
13.1 Replacing the Control Board 1.....	231
13.2 Replacing the Control Board 2.....	232
14. Replacing the LED Lamp	234
15. Replacing the M/C Cable	236
16. Calibration	239
16.1. Overview	239
16.2. Calibration Procedure	241
17. Maintenance Parts List	246
18. Option Parts List	249

Setup & Operation

This volume contains information for setup and operation of the Manipulators.
Please read this volume thoroughly before setting up and operating the Manipulators.

1. Safety



Installation and transportation of the Manipulators and robotic equipment shall be performed by qualified personnel and should conform to all national and local codes.

Please read this manual and other related manuals before installing the robot system or before connecting cables.

Keep this manual handy for easy access at all times.

1.1 Conventions

Important safety considerations are indicated throughout the manual by the following symbols. Be sure to read the descriptions shown with each symbol.

 WARNING	This symbol indicates that a danger of possible serious injury or death exists if the associated instructions are not followed properly.
 WARNING	This symbol indicates that a danger of possible harm to people caused by electric shock exists if the associated instructions are not followed properly.
 CAUTION	This symbol indicates that a danger of possible harm to people or physical damage to equipment and facilities exists if the associated instructions are not followed properly.

1.2 Design and Installation Safety

Only trained personnel should design and install the robot system. Trained personnel are defined as those who have taken robot system training and maintenance training classes held by the manufacturer, dealers, or local representative companies, or those who understand the manuals thoroughly and have the same knowledge and skill level as those who have completed the training courses.

To ensure safety, a safeguard must be installed for the robot system. For details on the safeguard, refer to the *Installation and Design Precautions* in the *Safety* chapter of the EPSON RC+ User's Guide.

The following items are safety precautions for design personnel:

 WARNING	<ul style="list-style-type: none"> ■ Personnel who design and/or construct the robot system with this product must read the <i>Safety</i> chapter in the EPSON RC+ User's Guide. Designing and/or constructing the robot system without understanding the safety requirements is extremely hazardous, and may result in serious bodily injury and/or severe equipment damage to the robot system.
--	--

 WARNING	<ul style="list-style-type: none"> ■ The Manipulator and the Controller must be used within the environmental conditions described in their respective manuals. This product has been designed and manufactured strictly for use in a normal indoor environment. Using the product in an environment that exceeds the specified environmental conditions may not only shorten the life of the product but may also cause serious safety problems. ■ The robot system must be used within the installation requirements described in the manuals. Using the robot system outside of the installation requirements may not only shorten the life of the product but also cause serious safety problems.
--	---

Further precautions for installation are described in the chapter *Setup & Operation 3. Environment and Installation*. Please read this chapter carefully to understand safe installation procedures before installing the robots and robotic equipment.

1.3 Operation Safety

The following items are safety precautions for qualified Operator personnel:

 WARNING	<ul style="list-style-type: none"> ■ Please carefully read the <i>Safety-related Requirements</i> in the <i>Safety</i> chapter of the <i>Safety and Installation</i> manual. Operating the robot system without understanding the safety requirements is extremely hazardous and may result in serious bodily injury and/or severe equipment damage to the robot system. ■ Do not enter the operating area of the Manipulator while the power to the robot system is turned ON. Entering the operating area with the power ON is extremely hazardous and may cause serious safety problems as the Manipulator may move even if it seems to be stopped. ■ Before operating the robot system, make sure that no one is inside the safeguarded area. The robot system can be operated in the mode for teaching even when someone is inside the safeguarded area. The motion of the Manipulator is always in restricted status (low speeds and low power) to secure the safety of an operator. However, operating the robot system while someone is inside the safeguarded area is extremely hazardous and may result in serious safety problems in case that the Manipulator moves unexpectedly. ■ Immediately press the Emergency Stop switch whenever the Manipulator moves abnormally during operation. Continuing the operation while the Manipulator moves abnormally is extremely hazardous and may result in serious bodily injury and/or severe equipment change to the robot system.
--	--

 WARNING	<ul style="list-style-type: none"> ■ Be sure to connect the AC power cable to a power receptacle. DO NOT connect it directly to a factory power source. To shut off power to the robot system, disconnect the power plug from the power source. Performing any work while connecting the AC power cable to a factory power source is extremely hazardous and may result in electric shock and/or malfunction of the robot system.
--	--

 <p>WARNING</p>	<ul style="list-style-type: none">■ Before performing any replacement procedure, turn OFF the Controller and related equipment, and then disconnect the power plug from the power source. Performing any replacement procedure with the power ON is extremely hazardous and may result in electric shock and/or malfunction of the robot system.■ Do not connect or disconnect the motor connectors while the power to the robot system is turned ON. Connecting or disconnecting the motor connectors with the power ON is extremely hazardous and may result in serious bodily injury as the Manipulator may move abnormally, and also may result in electric shock and/or malfunction of the robot system.
--	--

 <p>CAUTION</p>	<ul style="list-style-type: none">■ Whenever possible, only one person should operate the robot system. If it is necessary to operate the robot system with more than one person, ensure that all people involved communicate with each other as to what they are doing and take all necessary safety precautions.■ If the joints are operated repeatedly with the operating angle less than 5 degrees, they may get damaged early because the bearings are likely to cause oil film shortage in such situation. To prevent early breakdown, move the joints larger than 30 degrees for about five to ten times a day.■ Oscillation (resonance) may occur continuously in low speed Manipulator motion (Speed: approx. 5 to 20%) depending on combination of Arm orientation and end effector load. Oscillation arises from natural oscillation frequency of the Arm and can be controlled by following measures.<ul style="list-style-type: none">Changing Manipulator speedChanging the teach pointsChanging the end effector load
--	--

1.4 Emergency Stop

If the Manipulator moves abnormally during operation, immediately press the Emergency Stop switch. Pressing the Emergency Stop switch immediately changes the Manipulator to deceleration motion and stops it at the maximum deceleration speed.

However, avoid pressing the Emergency Stop switch unnecessarily while the Manipulator is running normally. Otherwise, the Manipulator may hit the peripheral equipment since the operating trajectory until the robot system stops is different from that in normal operation.

Do not press the Emergency Stop switch unnecessarily while the Manipulator is operating. Pressing the switch during operation makes the brakes work. This will shorten the life of the brakes due to the worn friction plates.

Normal brake life cycle: About 2 years (when the brakes are used 100 times/day)

Also, the Emergency Stop during operation applies impact on the reduction gear unit, and it may result in the short life of the reduction gear unit.

To place the robot system in emergency mode during normal operation, press the Emergency Stop switch while the Manipulator is not moving.

Refer to the Robot Controller manual for instructions on how to wire the Emergency Stop switch circuit.

Do not turn OFF the Controller while the Manipulator is operating.

If you attempt to stop the Manipulator in emergency situations such as “Safeguard Open”, make sure to stop the Manipulator using the Emergency Stop switch of the Controller.

If the Manipulator is stopped by turning OFF the Controller while it is operating, the following problems may occur.

Reduction of the life and damage of the reduction gear unit

Position gap at the joints

In addition, if the Controller was forced to be turned OFF by blackouts and the like while the Manipulator is operating, make sure to check the following points after power restoration.

Whether or not the reduction gear is damaged

Whether or not the joints are in their proper positions

If there is a position gap, perform calibration by referring to the Maintenance 16. Calibration in this manual.

Before using the Emergency Stop switch, be aware of the followings.

- The Emergency Stop (E-STOP) switch should be used to stop the Manipulator only in case of emergencies.
- To stop the Manipulator operating the program except in emergency, use Pause (halt) or STOP (program stop) commands.
Pause and STOP commands do not turn OFF the motors. Therefore, the brake does not function.
- For the Safeguard system, do not use the circuit for E-STOP.

For details of the Safeguard system, refer to the following manuals.

*EPSON RC+ User's Guide 2. Safety - Installation and Design Precautions
- Safeguard System*

Safety and Installation 2.6 Connection to EMERGENCY Connector

To check brake problems, refer to the following manuals.

Manipulator Manual Maintenance 2.1.2 Inspection Point

*- Inspection While the Power is ON
(Manipulator is operating)*

Safety and Installation

5.1.1 Manipulator

*- Inspection While the Power is ON
(Manipulator is operating)*

Free running distance in emergency

The Manipulator in operation cannot stop immediately after the Emergency Stop switch is pressed. However, time, angle, and distance of the free running vary by following factors:

Hand weight WEIGHT Setting ACCEL Setting
Workpiece weight SPEED Setting Posture etc.

Approximate time and distance of the free running are as follow:

Conditions of Measurement

	C4 series
ACCEL Setting	100
SPEED Setting	100
Load [kg]	4
WEIGHT Setting	4

Manipulator	C4-A601**	C4-A901**	
Robot Controller	RC700/RC700-A		
Free running time [s]	Arm #1	0.4	0.3
	Arm #2	0.4	0.4
	Arm #3	0.4	0.5
	Arm #4	0.3	
	Arm #5	0.4	
	Arm #6	0.3	
Free running angle [°]	Arm #1	85	60
	Arm #2	60	65
	Arm #3	55	55
	Arm #4	40	
	Arm #5	40	
	Arm #6	25	

1.5 How to Move Arms with the Electromagnetic Brake

There are two methods to release the electromagnetic brake. Follow either method to release the electromagnetic brake and move the arms manually.

1.5.1 Moving the arm using the brake release unit

Follow the method when you just unpack the delivered boxes or when the Controller does not start up yet.

1.5.2 Moving the arm using the software

Follow the method when you can use the software.

While the electromagnetic brake is ON (such as in emergency mode), you cannot move any arm by pushing manually.

Arm Motion

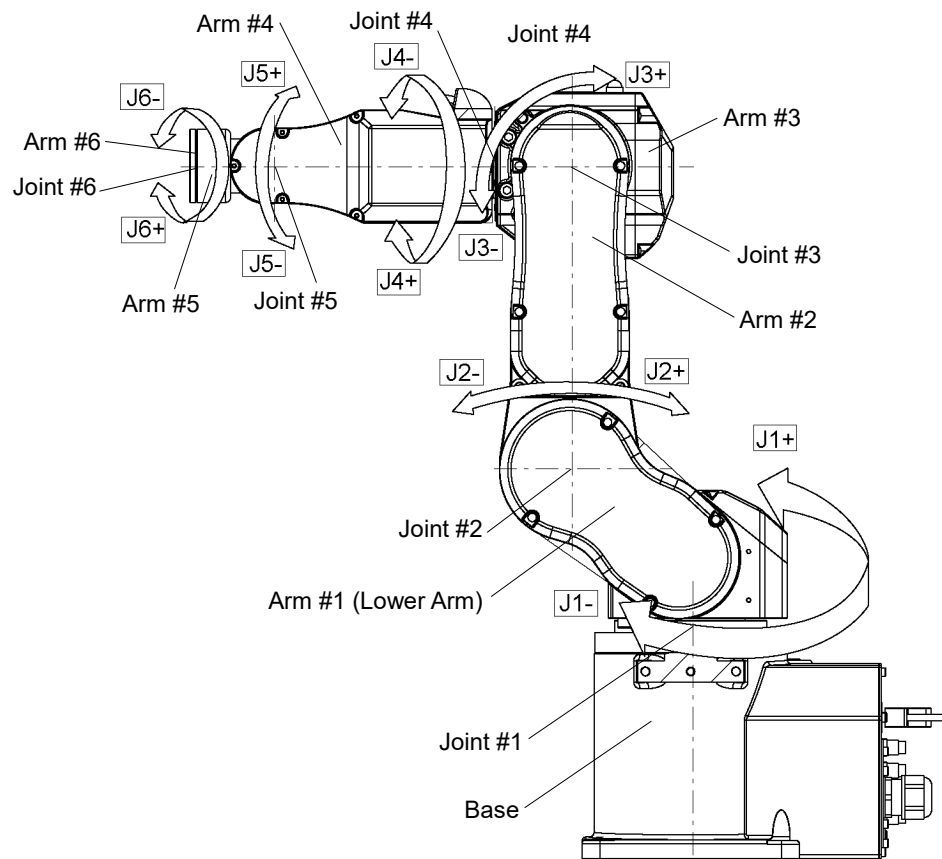

1.5.1 Moving the Arm using the brake release unit

The C4 series has the Brake Release Unit as an option.
For details, refer to *Setup & Option: 6 Options*.

1.5.2 Moving the Arm using the software

 CAUTION	<ul style="list-style-type: none"> ■ Normally, release the brake of joints one by one. Take extra care if you need to release the brakes of two or more joints simultaneously. Releasing the brakes of two or more joints simultaneously may cause hands and fingers to be caught and/or equipment damage to or malfunction of the Manipulator as the arms of the Manipulator may move in unexpected directions. ■ Be careful of the arm falling when releasing the brake. While the brake is being released, the Manipulator's arm falls by its own weight. The arm falling may cause hands and fingers to be caught and/or may cause equipment damage to or malfunction of the Manipulator. ■ Before releasing the brake, be sure to keep the Emergency Stop switch handy so that you can immediately press the Emergency Stop switch. Otherwise, you cannot immediately stop the arm falling due to an erroneous operation. The arm falling may cause equipment damage to and/or malfunction of the Manipulator.
--	--

EPSON
RC+

After releasing the Emergency Stop switch, execute the following command in [Command Window].

```
>Reset
```

```
>Brake Off, [the number (from 1 to 6) corresponding to the arm whose brake will be turned OFF]
```

Execute the following command to turn on the brake again.

```
>Brake On, [The number (from 1 to 6) corresponding to the arm whose brake will be turned ON]
```

1.6 Precaution for Operation in Low Power Status

In the low power status, the Manipulator operates at low speed and low torque. However, comparatively high torque as shown in the table below may be generated to support the Manipulator's own weight.

Carefully operate the Manipulator since it may get your hands or fingers caught during operation. The Manipulator may also collide with peripheral equipment and cause equipment damage to or malfunction of the Manipulator.

Maximum Joint Torque in Low Power Status

[Unit: N·m]

Joint	#1	#2	#3	#4	#5	#6
Joint Torque	116.24	193.74	59.31	12.45	11.41	6.88



 CAUTION	<ul style="list-style-type: none"> ■ Carefully operate the Manipulator in the low power status. A comparatively high joint torque may be generated. It may cause your hands and fingers caught and/or cause equipment damage to or malfunction of the Manipulator as it may collide with peripheral equipment.
--	---

1.7 Warning Labels

The Manipulator has the following warning labels.

The warning labels are attached around the locations where specific dangers exist. Be sure to comply with descriptions and warnings on the labels to operate and maintain the Manipulator safely.

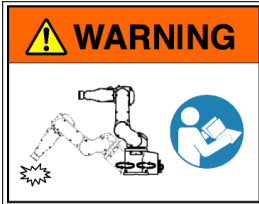
Do not tear, damage, or remove the warning labels. Use meticulous care when handling those parts or units to which the following warning labels are attached as well as the nearby areas.

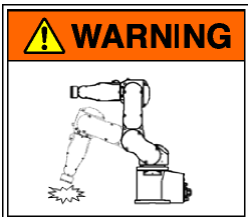
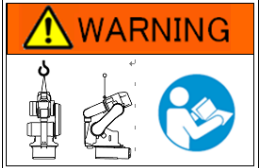
Location	Warning Label	NOTE
A	 <div data-bbox="560 622 842 860" style="border: 1px solid black; padding: 5px;"> <p>WARNING / AVERTISSEMENT</p> <p>Take measures to prevent the manipulator from falling and dropping before removing base mounting bolts.</p> <p>Prendre les mesures nécessaires pour empêcher le manipulateur de tomber avant de démonter les vis de fixation de la base.</p> </div>	To avoid getting hands or fingers caught, fold the Arm and fix it with a belt or a similar tool before removing the base mounting screws.
B	 <div data-bbox="517 887 863 1070" style="border: 1px solid black; padding: 5px;"> <p>WARNING / AVERTISSEMENT</p> <p>When moving, robot arm can cause death, or serious injury. Do not enter work envelope.</p> <p>En se déplaçant, le bras du robot peut provoquer des blessures graves ou mortelles. Ne pas pénétrer dans l'enveloppe de travail.</p> </div>	Do not enter the work space when the Manipulator is operating. It is extremely hazardous since the Arm may collide and cause serious safety problems,
C		Do not touch the current-carrying parts inside the Manipulator while the power is ON. It may cause electrical shock.
D		Be careful of the arm falling due to its own weight when pressing the brake release switch. These labels are attached on the optional brake release box
	<div data-bbox="280 1487 619 1704" style="border: 1px solid black; padding: 5px;"> <p>WARNING/AVERTISSEMENT</p> <p>EMERGENCY BRAKE RELEASE</p> <p>1. Turn off the controller.</p> <p>2. Operate the brake release unit using instructions on the brake release unit.</p> <p>DESSERRAGE DU FREIN D'URGENCE</p> <p>1. Éteindre le contrôleur.</p> <p>2. Utiliser l'élément de desserrage de frein à l'aide des instructions sur l'élément de desserrage de frein.</p> </div>	When the brake release box is used: Details of procedures for releasing the brakes using the brake release box are described in the Manipulator manuals.
E	 <div data-bbox="560 1778 855 1966" style="border: 1px solid black; padding: 5px;"> <p>WARNING/ AVERTISSEMENT</p> <p>Follow instructions manual during lifting and transportation.</p> <p>Respecter les instructions du manuel d' utilisation pendant le levage et le transport.</p> </div>	Only authorized personnel should perform sling work and operate a crane and a forklift. When these operations are performed by unauthorized personnel, it is extremely hazardous and may result in serious bodily injury and/or severe equipment damage to the robot system.

Location	Label
F	<p>MODEL : <u>C4-A601S</u> SERIAL NO. : *C40E000001* MANUFACTURED : <u>12 / 2012</u> WEIGHT : 27kg MAXPAYLOAD : 4kg MOTOR POWER AXIS1 : 400W AXIS2 : 400W AXIS3 : 150W AXIS4 : 50W AXIS5 : 50W AXIS6 : 50W SEIKO EPSON CORPORATION MADE IN CHINA .</p>
G	<p>Air pressure max. 0.59Mpa, 86psi</p>

Location of Labels

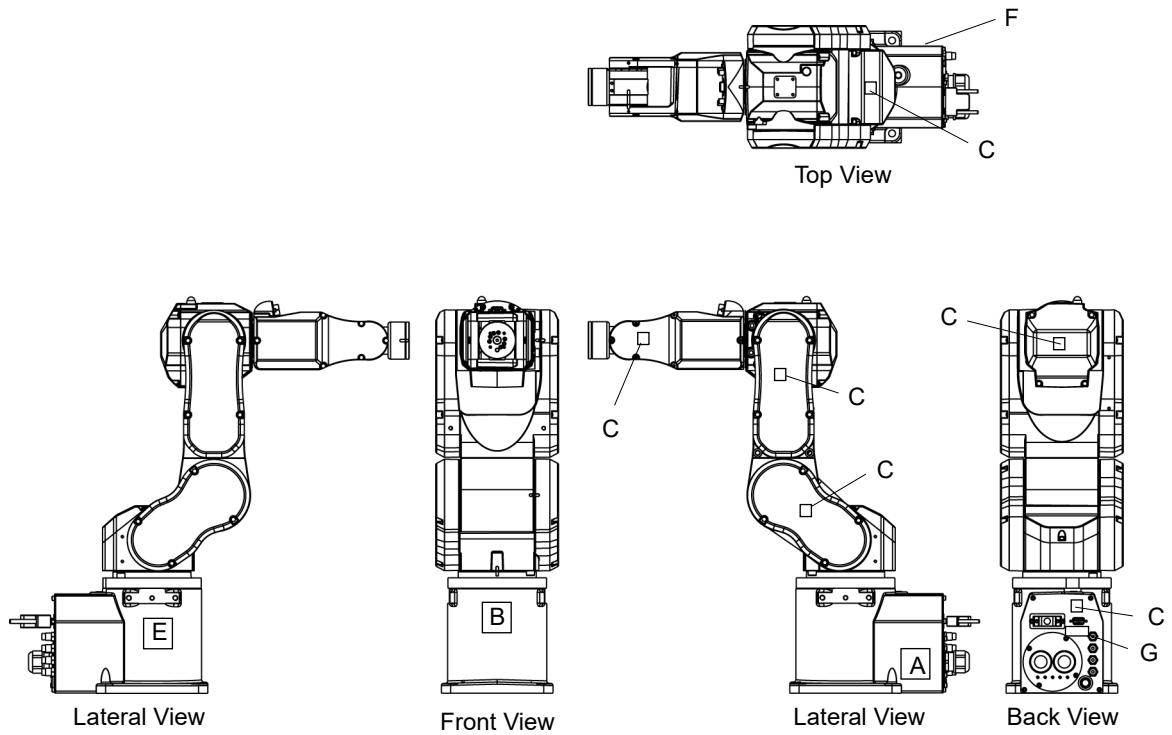

2. Specifications

2.1 Features of Manipulators

Speed & Accuracy

Increased productivity by balanced, best-in class fast and accurate operation.

C4-A601**

Average cycle time (300 mm) 0.39 s (Speed 100 / Accel 100)

0.37 s (Speed 100 / Accel 120)

Repeatability error ± 0.02 mm

C4-A901**

Average cycle time (300 mm) 0.49 s (Speed 100 / Accel 100)

0.47 s (Speed 100 / Accel 120)

Repeatability error ± 0.03 mm

Slim Body

High space efficiency

Manipulator size is only 1/44 of its motion range

Small elbow area (Joint #3) which is half of that of the existing models

Less interference with peripherals, walls, and ceiling permits more compact installation

Skillful Wrist

Compact wrist (Joint #5) with wide motion range enables smooth movement and the ability to work from many angles

Minimal interference with surroundings improves flexibility in hand design

2.2 Model Number

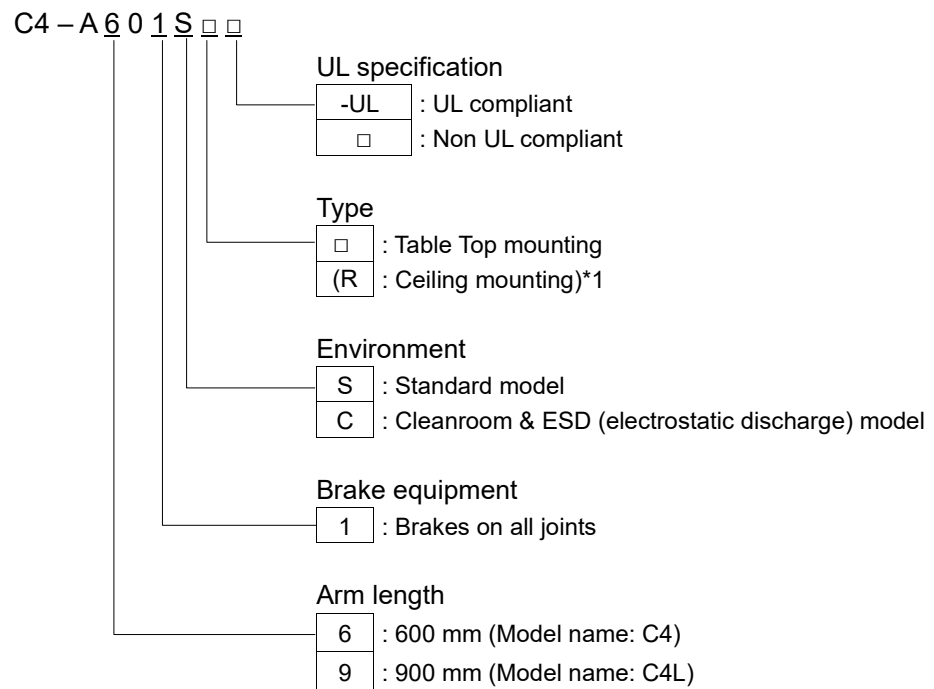

*1 Manipulators are set to “Table Top mounting” at shipment. To use the Manipulators as “Ceiling mounting”, you need to change the model settings.

For details on how to change the model settings, refer to *5.5 Changing the Robot*, and *EPSON RC+ User’s Guide Robot Configuration*.

2.3 Part Names and Motion Range of Each Arm

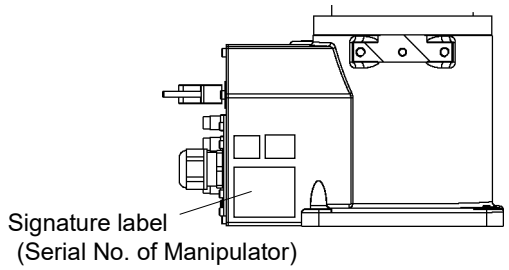
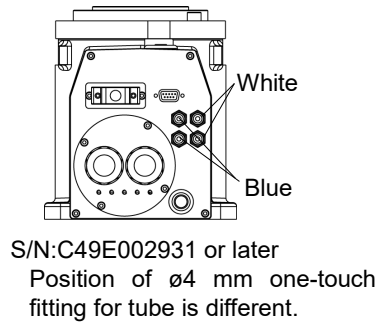
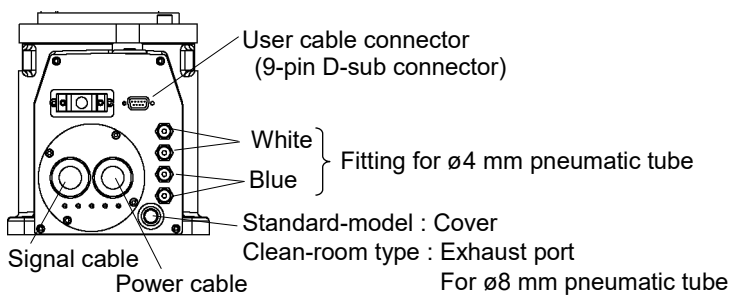
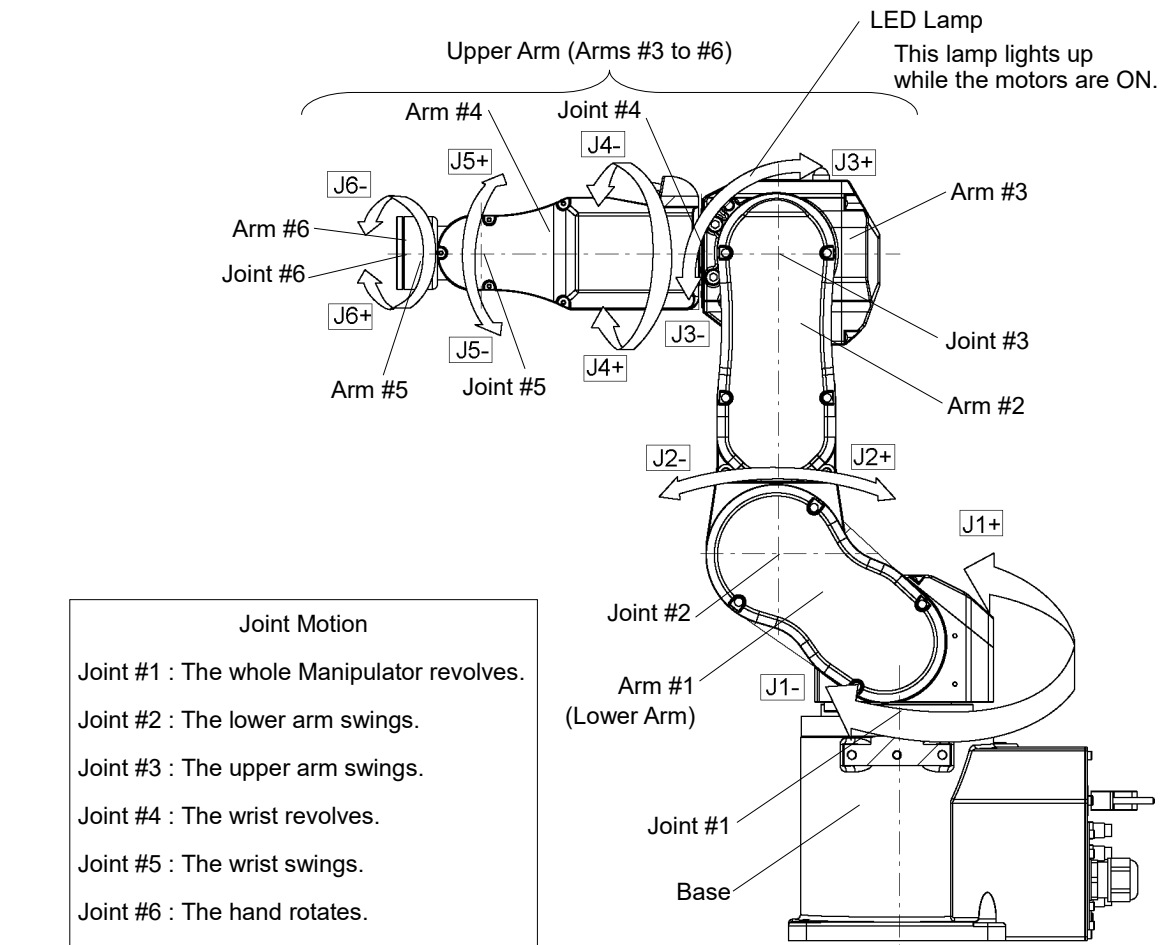

NOTE When the LED lamp is lighting or the Controller power is on, the current is being applied to the Manipulator. (The LED lamp may not be seen depending on the Manipulator's posture. Be very careful.) Performing any work with the power ON is extremely hazardous and it may result in electric shock and/or improper function of the robot system. Make sure to turn OFF the Controller power before the maintenance work.

2.4 Outer Dimensions

2.4.1 C4-A601**

[Unit: mm]

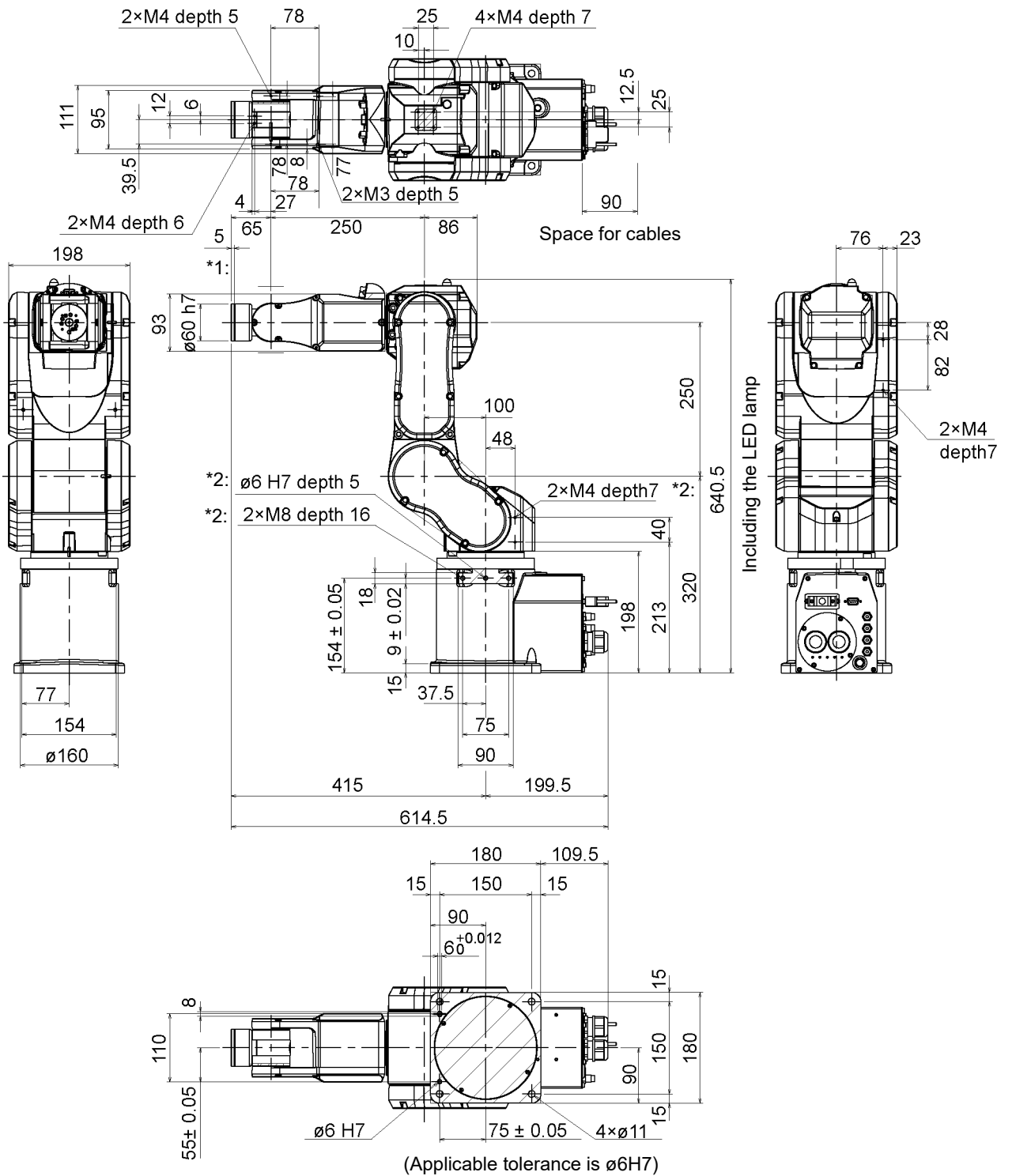

*1: Applicable area

*2: Same for the other side

2.4.2 C4-A901**

[Unit: mm]

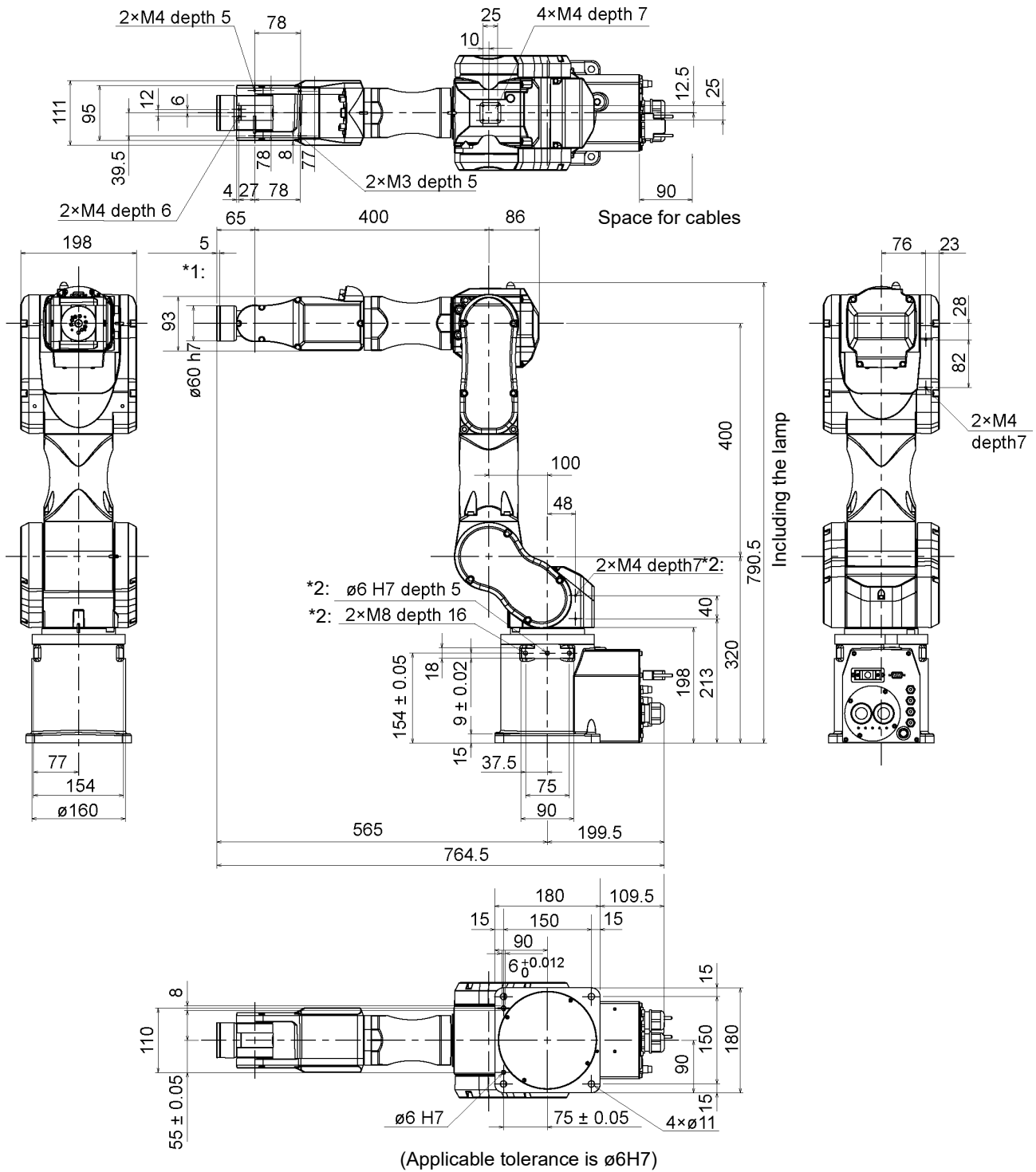

2.5 Standard Motion Range

2.5.1 C4-A601**

[Unit: mm]

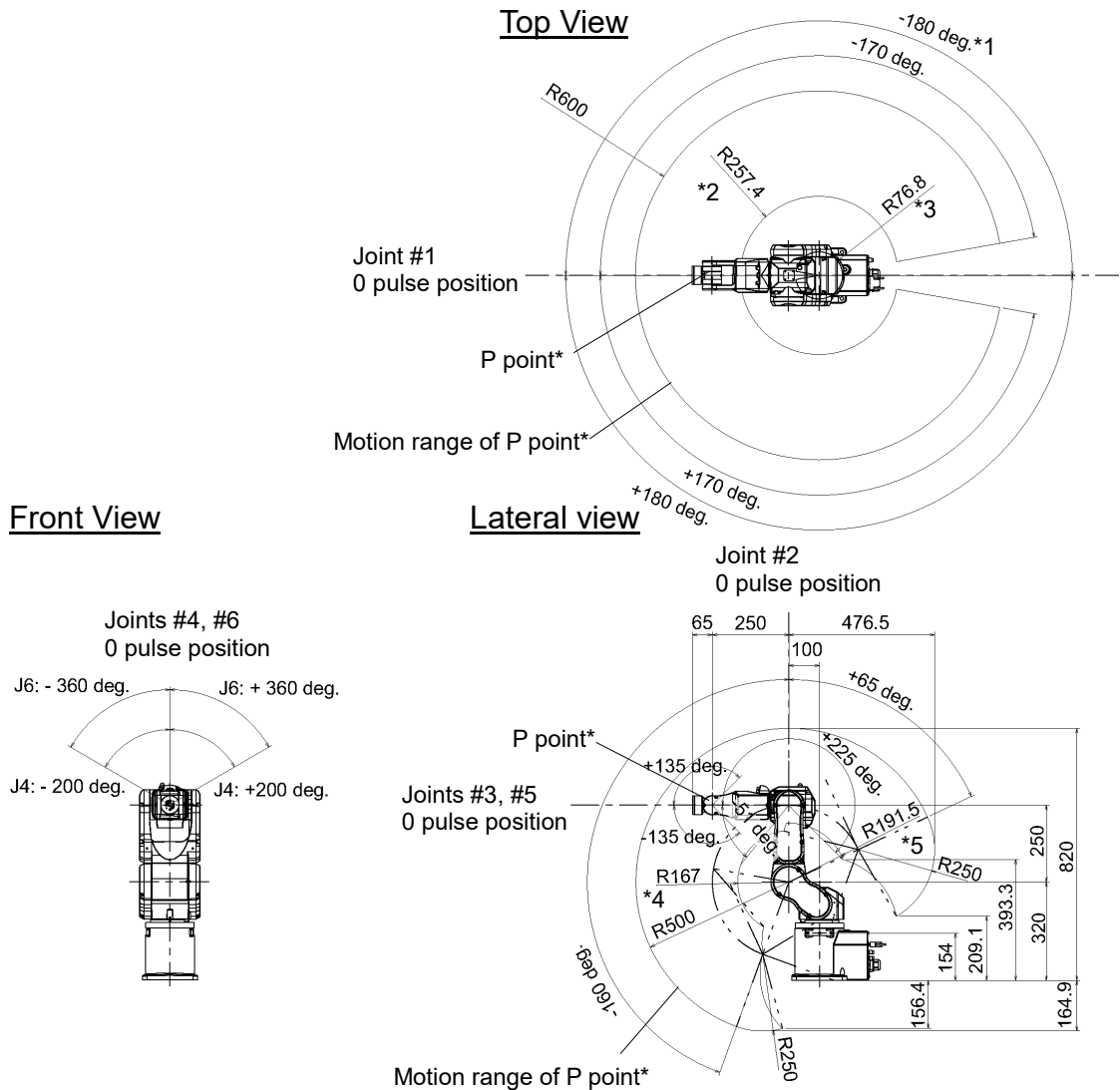

(deg. = °)

* P point : Intersection of the rotation centers for Joint #4, #5, and #6

*1 : Joint #1 without mechanical stop ($\pm 180^\circ$)

For the mechanical stop removal procedure, refer to *Setup & Operation: 5.2.1 Motion Range Setting of Arm #1*.

*2 : P point from top with Joint #3 declining -51° (Joint #1 center – P point center)

*3 : P point from top with Joint #3 tilting up $+225^\circ$ (Joint #1 center – P point center)

*4 : P point from lateral with Joint #3 declining -51° (Joint #2 center – P point center)

*5 : P point from lateral with Joint #3 tilting up $+225^\circ$ (Joint #2 center – P point center)



■ Pay attention to the arm pose of the basic arms (Arms #1, #2, and #3) when operating the Manipulator. Arm #5 moves keeping a constant angle regardless of the arm pose. Depending on the arm pose of the basic arms, the wrist may collide with the Manipulator. The collision may cause equipment damage to and/or malfunction of the Manipulator.

2.5.2 C4-A901**

[Unit: mm]

Top View

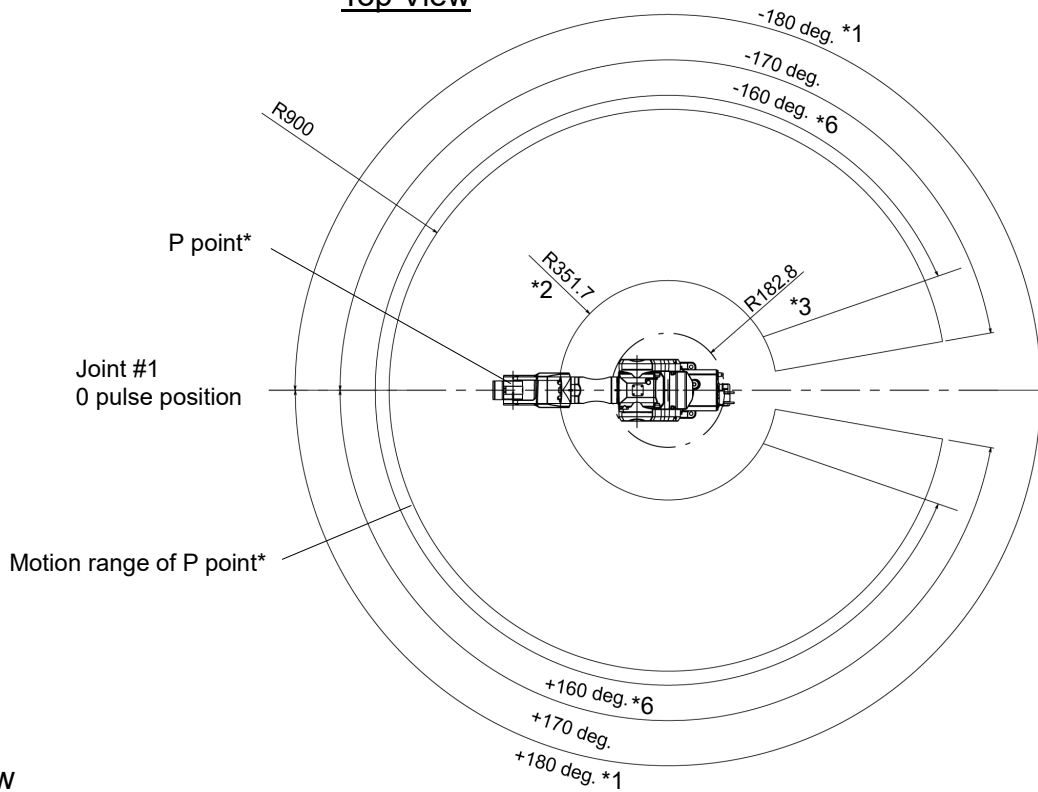

Front View

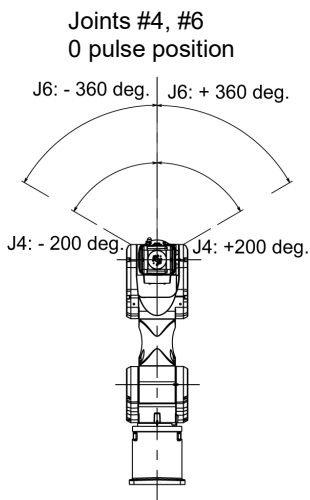

Lateral view

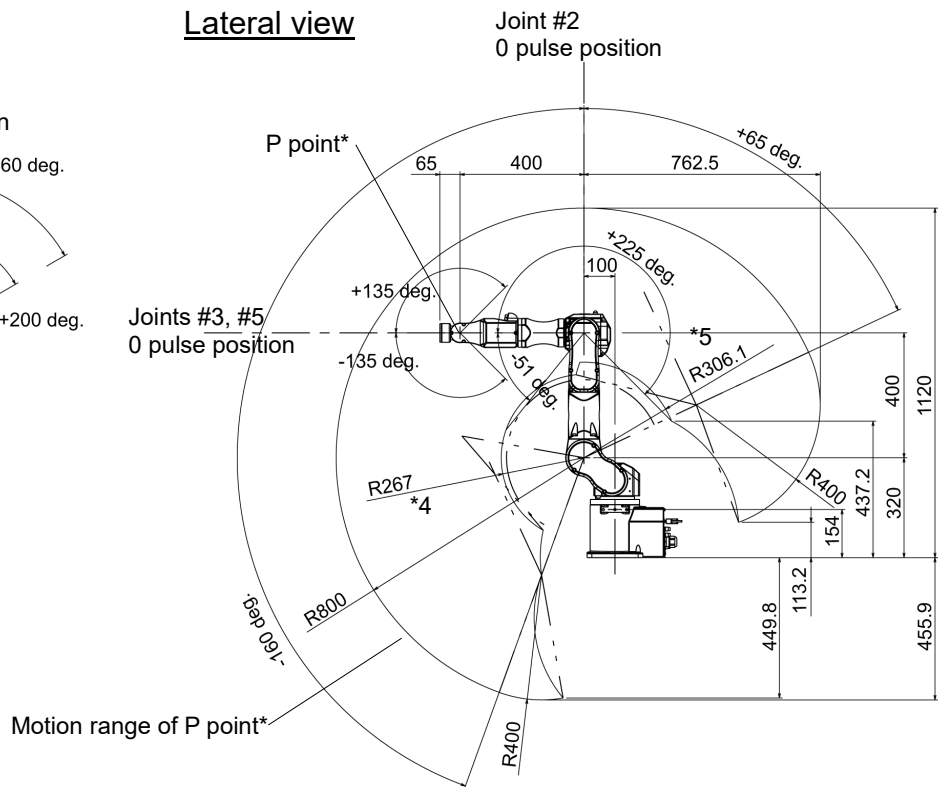

(deg. = °)

- * P point : Intersection of the rotation centers for Joint #4, #5, and #6
- *1 : Joint #1 without mechanical stop ($\pm 180^\circ$)
For the mechanical stop removal procedure, refer to Setup & Operation: 5.2.1 Motion Range Setting of Arm #1.
- *2 : P point from top with Joint #3 declining -50° (Joint #1 center – P point center)
- *3 : P point from top with Joint #3 tilting up $+210^\circ$ (Joint #1 center – P point center)
- *4 : P point from lateral with Joint #3 declining -50° (Joint #2 center – P point center)
- *5 : P point from lateral with Joint #3 tilting up $+210^\circ$ (Joint #2 center – P point center)
- *6 : Max. motion range of Joint #1 for UL specification of C4L is $\pm 160^\circ$.



CAUTION

- Pay attention to the arm pose of the basic arms (Arms #1, #2, and #3) when operating the Manipulator. Arm #5 moves keeping a constant angle regardless of the arm pose. Depending on the arm pose of the basic arms, the wrist may collide with the Manipulator. The collision may cause equipment damage to and/or malfunction of the Manipulator.

2.6 Specifications

2.6.1 Specifications table

Item		Specification	
Model Number		C4-A601**	C4-A901**
Model Name		C4	C4L
Mounting type		Table Top mounting (Ceiling mounting) *1	
Weight (not include the weight of cables or shipping jigs)		27 kg (59.5 lbs.)	29 kg (63.9 lbs.)
Driving method		All joints AC servo motor	
Max. operating speed *2	Joint #1	450°/s	275°/s
	Joint #2	450°/s	275°/s
	Joint #3	514°/s	289°/s
	Joint #4	555°/s	
	Joint #5	555°/s	
	Joint #6	720°/s	
Maximum synthetic speed		9459 mm/s	8495 mm/s
Repeatability		Joint #1 to #6 ± 0.02 mm ± 0.03 mm	
Max. motion range	Joint #1	± 170°	±170° (UL specification ± 160°)
		± 180° without the mechanical stop	
		-	UL specification: ± 160°
	Joint #2	- 160° to + 65°	
	Joint #3	- 51° to + 225°.	
	Joint #4	± 200°	
	Joint #5	±135°	
	Joint #6	±360°	
Max. pulse range	Joint #1	± 4951609	± 8102633 (UL specification 7626008)
		± 5242880 without the mechanical stop	± 8579259 without the mechanical stop
		-	UL specification: ± 7626008
	Joint #2	- 4660338 to + 1893263	- 7626008 to + 3098066
	Joint #3	- 1299798 to + 5734400	- 2310751 to + 10194489
	Joint #4	± 4723316	
	Joint #5	± 3188238	
	Joint #6	± 6553600	
Resolution	Joint #1	0.0000343°/pulse	0.0000210°/pulse
	Joint #2	0.0000343°/pulse	0.0000210°/pulse
	Joint #3	0.0000392°/pulse	0.0000221°/pulse
	Joint #4	0.0000423°/pulse	
	Joint #5	0.0000423°/pulse	
	Joint #6	0.0000549°/pulse	
Motor rated capacity	Joint #1	400 W	
	Joint #2	400 W	
	Joint #3	150 W	
	Joint #4	50 W	
	Joint #5	50 W	
	Joint #6	50 W	
Payload *3	Rated	1 kg	
	Max.	4 kg 5 kg with arm downward positioning	

Item		Specification	
Allowable moment	Joint #4	4.41 N·m (0.45 kgf·m)	
	Joint #5	4.41 N·m (0.45 kgf·m)	
	Joint #6	2.94 N·m (0.3 kgf·m)	
Model Number		C4-A601**	C4-A901**
Model Name		C4	C4L
Allowable moment of inertia (GD ² /4) *4	Joint #4	0.15 kg·m ²	
	Joint #5	0.15 kg·m ²	
	Joint #6	0.10 kg·m ²	
Installed wire for customer use		9 wires (D-sub)	
Installed pneumatic tube for customer use *5		4 pneumatic tubes, Allowable pressure: 0.59MPa (6 kgf/cm ²) (86 psi)	
Environmental requirements *6	Ambient Temperature	5 to 40°	
	Ambient relative humidity	20 to 80 % (no condensation)	
	Vibration	4.9 m·s ⁻² (0.5 G) or less	
Noise level *7		LAeq = 70 dB (A) or under	
Environment		Standard / Cleanroom model & ESD *8	
Applicable Controller		RC700, RC700-A (UL specification: RC700-A only)	
Default values (Max. setting values)	SPEED	5 (100)	
	ACCEL *9	5, 5 (120, 120)	
	SPEEDS	50 (2000)	
	ACCELS	200 (25000)	200 (15000) *10
	FINE	10000, 10000, 10000, 10000, 10000, 10000 (65535, 65535, 65535, 65535, 65535, 65535)	
	WEIGHT	1 (5)	
Safety standard		CE Marking: EMC Directive, Machinery Directive KC Marking / KCs Marking UL standards (In case of UL specification): UL1740 ANSI/RIA R15.06 NFPA 79	

*1: Manipulators are set to “Table Top mounting” at shipment. To use the Manipulators as “Ceiling mounting”, you need to change the model settings.

For details on how to change the model settings, refer to 5.5 *Changing the Robot*, and *EPSON RC+ User's Guide Robot Configuration*.

*2: In case of PTP control

*3: If the payload exceeds the maximum payload, refer to the section “*Restrictions on payload exceeding the maximum payload*” in *Setup & Operation 4.3.1 WEIGHT Setting*.

*4: If the center of gravity is at the center of each arm. If the center of gravity is not at the center of each arm, set the eccentric quantity using INERTIA command.

*5: For details of the installed pneumatic tube for customer use, refer to the *Setup & Operation 3.6 User Wires and Pneumatic Tubes*.

*6: For details of the environmental requirements, refer to the *Setup & Operation 3.1 Environmental Conditions*.

*7: Conditions of Manipulator at measurement are as follows:

Operating conditions: Under rated load, 6 arms simultaneous motion, maximum speed, maximum acceleration/deceleration, and duty 50%.

Measurement point: 1000 mm apart from the rear of Manipulator

*8: The exhaust system in the Cleanroom-model Manipulator draws air from the base interior and arm cover interior.

A crack or other opening in the base unit can cause loss of negative air pressure in the outer part of the arm, which can cause increased dust emission.

Cleanliness level : Class ISO 3 (ISO14644-1)

Exhaust System : Fitting for $\varnothing 8$ mm pneumatic tube

Refer to *Setup & Operation: 3.6 User Wires and Pneumatic Tubes.*

60 L/min vacuum

Exhaust tube : Polyurethane tube

Outer diameter: $\varnothing 8$ mm (Inner diameter: $\varnothing 5$ to 6 mm)

ESD specification uses resin materials with antistatic treatment. This model controls adhesion of dust due to electrification.

*9: In general use, Accel setting 100 is the optimum setting that maintains the balance of acceleration and vibration when positioning. Although values larger than 100 can be set to Accel, it is recommended to minimize the use of large values to necessary motions since operating the Manipulator continuously with the large Accel setting may shorten the product life remarkably.

*10: Maximum AccelS setting value for payload of 4 kg or more is 12000.

Although setting the value exceeding 12000 does not cause an error, do not set the value in order to prevent Manipulator malfunction.

2.6.2 Option

C4 series have the following options.

Brake release unit

Camera mounting plate

PS compatible plate (Tool adapter, Base adapter)

Base side angled fittings

Base side fittings

Adjustable Mechanical Stop (Joint #2: Only C4-A901**)

For details of options, refer to *Setup & Operation: 6. Options.*

2.7 How to Set the Model

The Manipulator for your system has been set before shipment from the factory.



- When you need to change the setting of the Manipulator model, be sure to set the Manipulator model properly. Improper setting of the Manipulator model may result in abnormal or no operation of the Manipulator and/or cause safety problems.



If the custom specifications number (MT***) is described on MODEL of the signature label (S/N label), the Manipulator has custom specifications. (A label with only the custom specifications number may be attached depending on shipment time).

The custom specifications may require a different configuration procedure; check the custom specifications number (MT***) and please contact the supplier of your region if necessary.

The Manipulator model can be set from software.

Refer to the chapter *Robot Configuration* in the *EPSON RC+ User's Guide*.

3. Environment and Installation

Installation and transportation of robots and robotic equipment shall be performed by qualified personnel and should conform to all national and local codes.

3.1 Environmental Conditions

A suitable environment is essential for the robot system to function properly and safely. Be sure to install the robot system in an environment that meets the following conditions:

Item	Conditions
Ambient temperature*	5 to 40 °C
Ambient relative humidity	20 % to 80 % (no condensation)
First transient burst noise	1 kV or less (Signal wire)
Electrostatic noise	4 kV or less
Environment	<ul style="list-style-type: none"> - Install indoors. - Keep away from direct sunlight. - Keep away from dust, oily smoke, salinity, metal powder or other contaminants. - Keep away from flammable or corrosive solvents and gases. - Keep away from water. - Keep away from shock or vibration. - Keep away from sources of electric noise.

* The ambient temperature conditions are for the Manipulators only. For the Controller the Manipulators are connected to, refer to the Robot Controller manual.



When using the Manipulators in inadequate environments that do not meet the above conditions, please contact the supplier of your region.

Special Environmental Conditions

The surface of the Manipulator has general oil resistance. However, if your requirements specify that the Manipulator must withstand certain kinds of oil, please contact the supplier of your region.

Rapid change in temperature and humidity can cause condensation inside the Manipulator.

If your requirements specify that the Manipulator handles food, please contact the supplier of your region to check whether the Manipulator will damage the food or not.

The Manipulator cannot be used in corrosive environments where acid or alkaline is used. In a salty environment where the rust is likely to gather, the Manipulator is susceptible to rust.

 WARNING	<ul style="list-style-type: none"> Use an earth leakage breaker on the AC power cable of the Controller to avoid the electric shock and circuit breakdown caused by an unexpected water leak. Prepare the earth leakage breaker that pertains the Controller you are using. For details, refer to the Robot Controller manual.
--	---

 CAUTION	<ul style="list-style-type: none"> When cleaning the Manipulator, do not rub it strongly with alcohol or benzene. It may lose luster on the coated face.
--	---

3.2 Unpacking, Transportation, and Relocation

Using a cart or similar equipment, transport the Manipulator in the same conditions as it was delivered. Observe the following when unpacking the Manipulator. The installation shall be made by qualified installation personnel and should conform to all national and local codes.

 WARNING	<ul style="list-style-type: none"> Only authorized personnel should perform sling work and operate a crane or a forklift. When these operations are performed by unauthorized personnel, it is extremely hazardous and may result in serious bodily injury and/or severe equipment damage to the robot system. Stabilize the Manipulator with your hands when hoisting it. Unstable hoisting is extremely hazardous and may result in serious bodily injury and/or severe equipment damage to the robot system as the fall of the Manipulator.
--	--

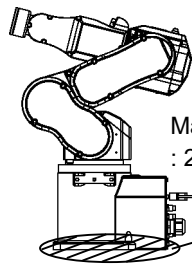
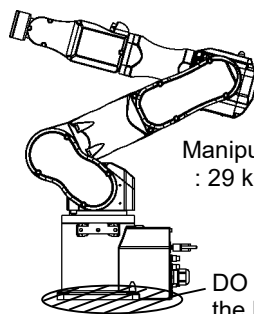
 CAUTION	<ul style="list-style-type: none"> When removing the anchor bolts, support the Manipulator to prevent falling. Removing the anchor bolts without supporting the Manipulator may get hands, fingers, or feet caught as the Manipulator may fall. To transport the Manipulator, secure it to the delivery equipment or have at least 2 people to hold it by hand. Also, do not hold the bottom of the base (the screened parts in the figure). Holding these parts by hand is extremely hazardous and may cause your hands and fingers caught. <div style="display: flex; justify-content: space-around;"> <div style="text-align: center;"> <p>C4-A601**</p>  <p>Manipulator weight : 27 kg (59.5 lbs.)</p> <p>DO NOT hold the bottom of the base by hand.</p> </div> <div style="text-align: center;"> <p>C4-A901**</p>  <p>Manipulator weight : 29 kg (63.9 lbs.)</p> <p>DO NOT hold the bottom of the base by hand.</p> </div> </div> <ul style="list-style-type: none"> Avoid excessive vibration or shock during Manipulator transporting. Excessive vibration or shock may cause equipment damage to and/or malfunction of the Manipulator.
--	---

During unpacking and relocation, avoid applying external force to the arms and motors of the Manipulator.

When transporting the Manipulator for a long distance, secure it to the delivery equipment so that the Manipulator cannot fall. If necessary, pack the Manipulator in the same way as it was delivered.

When condensation occurs on the Manipulator during transport or storage, turn ON the power only after the condensation dries.

Be sure to transport and store the robot system in environments that meet the following conditions:

Item	Conditions
Ambient temperature	0 to 45 °C
Ambient relative humidity	20 to 80 %

When using the Manipulator for the robot system again after long-term storage, perform a test run to verify that the Manipulator works properly. Then, operate the Manipulator thoroughly.

Relocating

Follow the procedures described below when relocating the Manipulator.

- (1) Turn OFF the power for all devices and unplug the power cable connector and signal cable connector from the Controller.

Do not unplug the M/C cable (power cable and signal cable) from the Manipulator.
(MC cable 3 m: 2 kg)



Remove the mechanical stops if using them to limit the motion range.

For details on the motion range, refer to the *Setup & Operation 5.2 Motion Range Setting by Mechanical Stops*.

- (2) Unscrew the anchor bolts. Then, remove the Manipulator from the base table.

- (3) C4-A601**

Position the Manipulator as shown in the figure. Then, secure the Manipulator to the delivery equipment or have at least 2 people to carry the Manipulator.

Recommend: Joint #2 +65°.
Joint #3 -51°.

Do not hold the bottom of the base (the screened parts in the figure). Holding these parts by hand is extremely hazardous and may cause your hands and fingers to be caught.

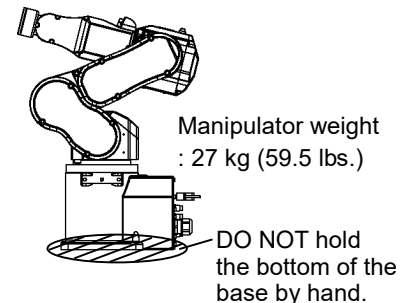

- (3) C4-A901**

Position the Manipulator as shown in the figure. Then, secure the Manipulator to the delivery equipment or have at least 3 people to carry the Manipulator.

Recommend: Joint #2 +53°.
Joint #3 -51°.

Do not hold the bottom of the base (the screened parts in the figure). Holding these parts by hand is extremely hazardous and may cause your hands and fingers to be caught.

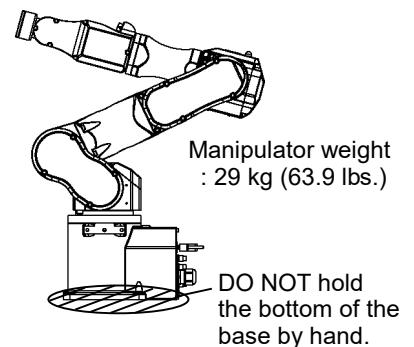

Using Eyebolt

Check that the eyebolts are securely fastened before carrying the Manipulator.

After transporting the Manipulator, remove the eyebolts and keep them for future use.

The eyebolts and wire must be strong enough to withstand the weight (See the figures below). If you use the eyebolts to lift up the Manipulator, be sure to use the bifilar wire of 1 m long or more to avoid contact with the Arm #4 side cover.

Also, the Manipulator may swing while being lifted up even when using the appropriate length of wire, so be sure to handle it with care.

Take extra care if you use the wire of 240 mm-long or shorter (for C4-A601**), or 360 mm-long or shorter (for C4-A901**), to lift the Manipulator, because the wire is likely to touch the Arm #4 side cover and break the Manipulator.

(deg.= °)

C4-A601**

Holes for eye bolt
2-M6 depth 12.5

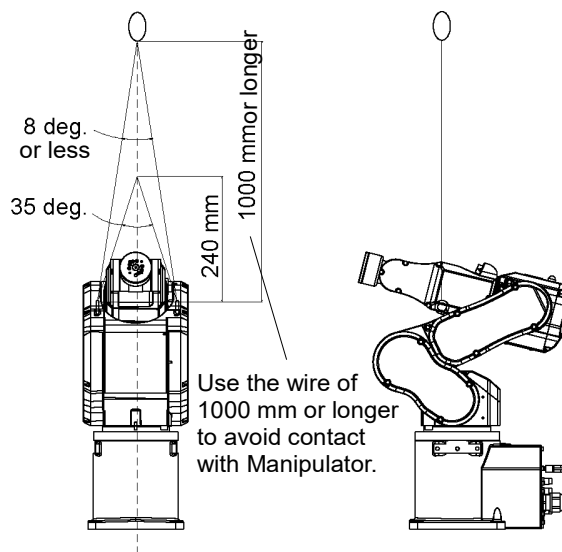
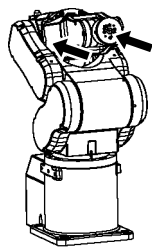

C4-A901**

Lifting load
: 29 kg (63.9 lb.)

Holes for eye bolt
2-M6 depth 12.5

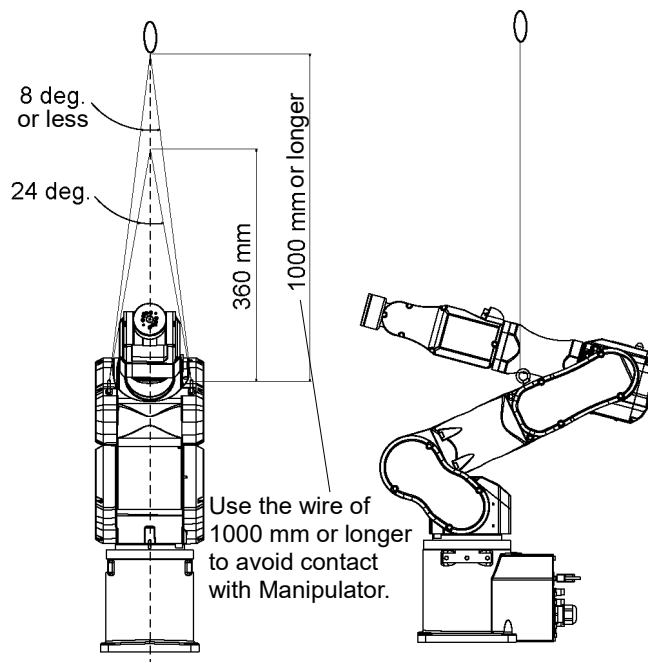

3.3 Mounting Dimensions

Mounting Area

Be sure to have the following space available in addition to the space for mounting the Manipulator, Controller, and peripheral equipment.

- Space for teaching points
- Space for maintenance and inspections (for installing jigs)
- Space for cables
- Space for mounting holes (only for V/P model)



The minimum bend radius of the power cable is 90 mm. When installing the cable, be sure to maintain sufficient distance from obstacles. In addition, leave enough space for other cables so that they are not bent forcibly.

Mounting Dimensions (C4 series)

[Unit: mm]

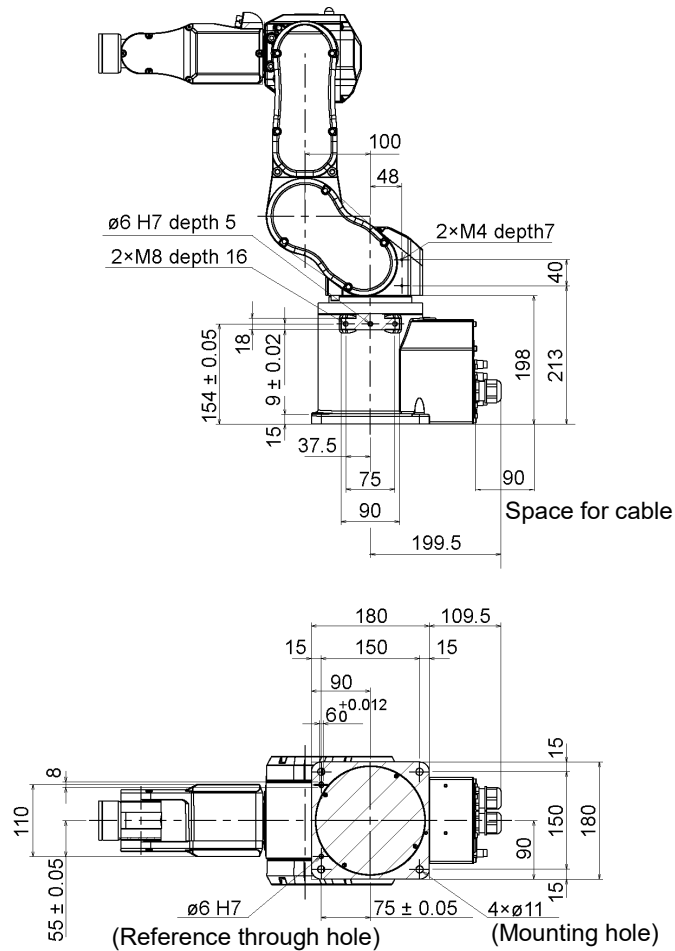

3.4 Installation

The installation shall be made by qualified installation personnel and should conform to all national and local codes.

 WARNING	<ul style="list-style-type: none"> ■ To ensure safety, a safeguard must be installed for the robot system. For details on the safeguard, refer to the <i>Installation and Design Precautions</i> in the <i>Safety</i> chapter of the EPSON RC+ User's Guide. ■ Install the Manipulator in a location with sufficient space so that a tool or a work piece does not touch a wall or a safeguard when the Manipulator extends its arm fully while holding a work piece. Installing the Manipulator at a location with insufficient space is extremely hazardous and may result in serious bodily injury and/or severe equipment damage to the robot system as a tool or a work piece may collide with a wall or a safeguard. ■ Anchor the Manipulator before turning ON the power to or operating the Manipulator. Turning ON the power to or operating the Manipulator that is not anchored is extremely hazardous and may result in serious bodily injury and/or severe equipment damage to the robot system as the Manipulator may fall down. ■ Before installing and operating the Manipulator, make sure that all parts of the Manipulator are in place and have no external defects. Missing or defective parts may cause improper operation of the Manipulator. Improper operation of the Manipulator is extremely hazardous and may result in serious bodily injury and/or severe equipment damage to the robot system.
--	---

 CAUTION	<ul style="list-style-type: none"> ■ The Manipulator must be installed to avoid interference with buildings, structures, utilities, other machines and equipment that may create a trapping hazard or pinch points. ■ Oscillation (resonance) may occur during operation depending on rigidity of the installation table. If the oscillation occurs, improve rigidity of the table or change the speed or acceleration and deceleration settings.
--	---

Mounting bolt

For the dimensions, refer to *Setup & Operation 3.3 Mounting Dimensions*.

There are four threaded holes for the Manipulator base.

Use M8 mounting bolts conforming to the strength of ISO898-1 property class 12.9.

Tightening torque: 32.0 N·m (326 kgf·cm)

Base table

A base table for anchoring the Manipulator is not supplied. Please make or obtain the base table for your Manipulator. The shape and size of the base table differ depending on the intended use of the robot system. The following is the basic requirements of Manipulator table for your reference.

The base table must not only be able to bear the weight of the Manipulator but also be able to withstand the dynamic movement of the Manipulator when it operates at maximum acceleration/deceleration. Ensure that there is enough strength on the base table by attaching reinforcing materials such as crossbeams.

The torque and reaction force produced by the movement of the Manipulator are as follows:

	C4-A601**	C4-A901**
Max. Horizontal rotating torque	500 N·m	700 N·m
Max. Horizontal reaction force	800 N	800 N
Max. Vertical rotating torque	600 N·m	1000 N·m
Max. Vertical reaction force	2500 N	2500 N

The plate for the Manipulator mounting face should be 30 mm thick or more and made of steel to reduce vibration. The surface roughness of the steel plate should be 25 μm or less.

The base table must be secured on the floor to prevent it from moving.

The Manipulator must be installed horizontally.

When using a leveler to adjust the height of the base table, use a screw with M16 diameter or more.

Connector

If you are passing cables through the holes on the base table, see the figures below.
[unit : mm]

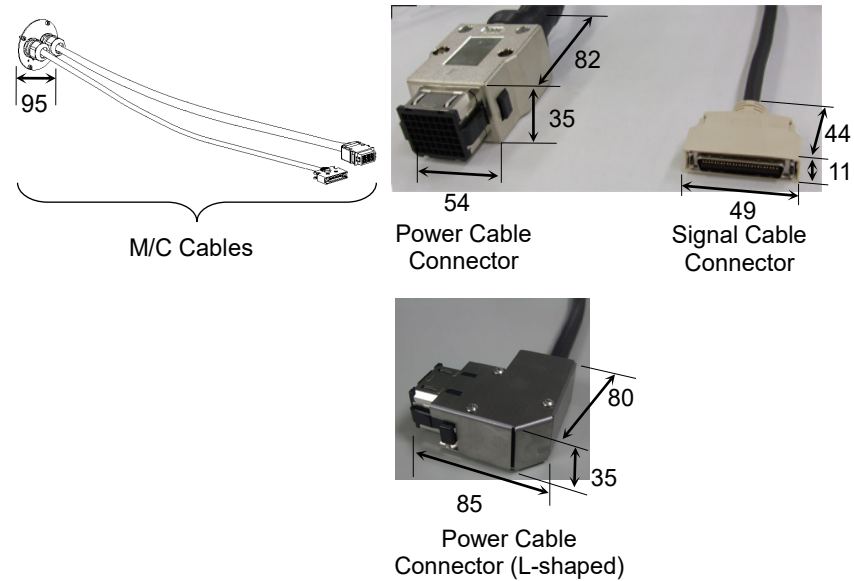

Do not remove the M/C cables from the Manipulator.





For environmental conditions regarding space when placing the Controller on the base table, refer to the Robot Controller manual.

When using the Manipulator in the clean room, follow the steps below before the installation.

- (1) Unpack it outside of the clean room.
- (2) Secure the Manipulator to delivery equipment such as a pallet with bolts so that the Manipulator does not fall.
- (3) Wipe off the dust on the Manipulator with a little alcohol or distilled water on a lint-free cloth.
- (4) Carry the Manipulator in the clean room.
- (5) Secure the Manipulator to the base table.

3.5 Connecting the Cables

 WARNING	<ul style="list-style-type: none"> ■ Before performing any replacement procedure, turn OFF the Controller and related equipment, and then disconnect the power plug from the power source. Performing any replacement procedure with the power ON is extremely hazardous and may result in electric shock and/or malfunction of the robot system. ■ Be sure to connect the AC power cable to a power receptacle. DO NOT connect it directly to a factory power source. To shut off power to the robot system, disconnect the power plug from the power source. Performing any work while connecting the AC power cable to a factory power source is extremely hazardous and may result in electric shock and/or malfunction of the robot system. ■ Be sure to connect the cables properly. Do not allow unnecessary strain on the cables. (Do not put heavy objects on the cables. Do not bend or pull the cables forcibly.) The unnecessary strain on the cables may result in damage to the cables, disconnection, and/or contact failure. Damaged cables, disconnection, or contact failure is extremely hazardous and may result in electric shock and/or improper function of the robot system. ■ Before wiring, turn OFF the Controller and related equipment, and then pull up a warning sign (e.g. DO NOT TURN ON THE POWER.). Wiring with the power ON is extremely hazardous and may result in electric shock and/or malfunction of the robot system. ■ Grounding the Manipulator is done by connecting with the Controller. Ensure that the Controller is grounded and the cables are correctly connected. If the ground wire is improperly connected to ground, it may result in the fire or electric shock. ■ When connecting / replacing the brake release unit or the external short connector, turn OFF the power to the Controller and the brake release unit. Inserting and removing the connector while the power is ON may result in electrical shock.
 CAUTION	<ul style="list-style-type: none"> ■ When connecting the Manipulator and the Controller, make sure that the serial numbers on each equipment match. Improper connection between the Manipulator and Controller may not only cause improper function of the robot system but also safety problems. The connection method varies with the Controller used. For details on the connection, refer to the Robot Controller manual. ■ Only authorized or certified personnel should be allowed to perform wiring. Wiring by unauthorized or uncertified personnel may result in bodily injury and/or malfunction of the robot system. ■ If the Manipulator is operated without connecting the brake release unit or the external short connector, the brakes cannot be released and it may cause damage on them. After using the brake release unit, be sure to connect the external short connector to the Manipulator, or check connection of the connector for the brake release unit.

Cleanroom-model Manipulator

For the Cleanroom-model, an exhaust system is necessary. For details, refer to *Setup & Operation: 2.6 Specifications*.

M/C Cable Connection method

Connect the power connector and the signal connector of the M/C cables to the Controller.

3.6 User Wires and Pneumatic Tubes

 CAUTION	<p>■ Only authorized or certified personnel should be allowed to perform wiring. Wiring by unauthorized or uncertified personnel may result in bodily injury and/or malfunction of the robot system.</p>
---	--

User electrical wires and pneumatic tubes are contained in the cable unit.

Electrical Wires

Rated Voltage	Allowable Current	Wires	Nominal Sectional Area	Outer Diameter	Note
AC/DC30 V	1 A	9	0.211 mm ²	ø8.3 ± 0.3 mm	Shielded

		Maker	Standard
9 pin	Suitable Connector	JAE	DE-9PF-N (Solder type), DEU-9PF-F0 (Crimping type)
	Clamp Hood	JAE	DE-C8-J9-F2-1R (Connector setscrew: #4-40 NC)

Pins with the same number, indicated on the connectors on both ends of the cables, are connected.

Pneumatic Tubes

Max. Usable Pneumatic Pressure	Pneumatic Tubes	Outer Diameter × Inner Diameter
0.59 MPa (6 kgf/cm ² : 86 psi)	4	ø4 mm × ø2.5 mm

Tubes with the same number, indicated in details of View A and B, are connected.

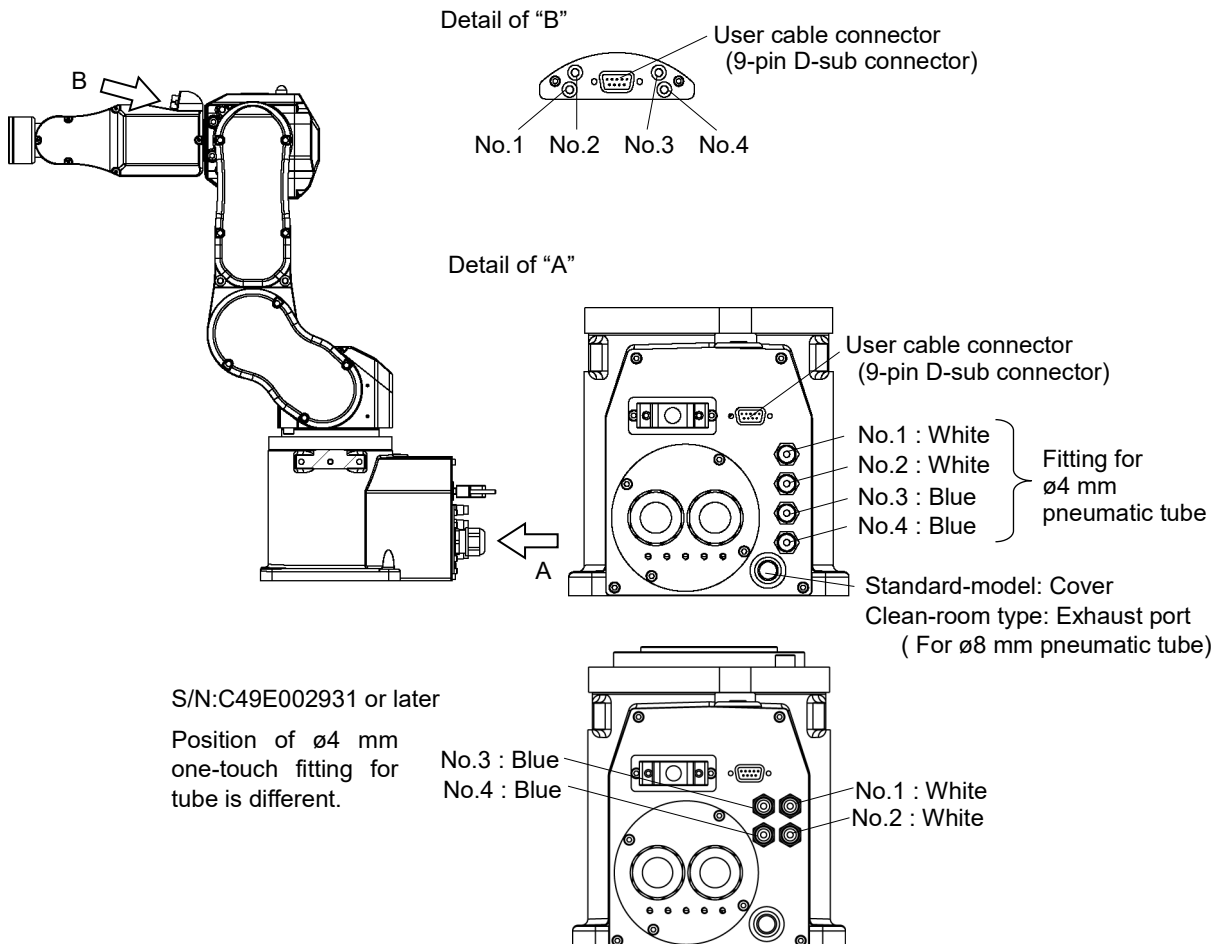

3.7 Checking the Basic orientation

After parts have been replaced (motors, reduction gear units, belts, etc.), the Manipulator cannot operate properly because a gap exists between the origin positions stored in each motor and these stored in the Controller. The process to compensate the position gap is called “Calibration”.

At the time of shipment, the basic orientation of the Manipulator shown below is set as the origin position.

After installing the Manipulator and setup the operating environment, move the Manipulator to the origin position and check if it moves to the basic position properly.

To make the Manipulator move to the origin position, select [Tool]-[Robot Manager] - [Control Panel] and click <Home>.

If the gap still exists and the Manipulator cannot be in the basic orientation after the calibration, please contact the supplier of your region.

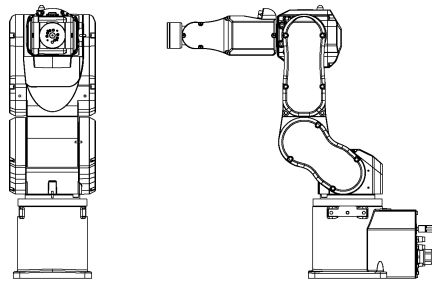

Basic orientation

4. End Effectors

4.1 Attaching an End Effector

Create an end effector for your Manipulator. Flange dimensions of the wrist attached to the end of Arm #6 is as below.

 CAUTION	<p>■ If you use an end effector equipped with a gripper or chuck, connect wires and/or pneumatic tubes properly so that the gripper does not release the work piece when the power to the robot system is turned OFF. Improper connection of the wires and/or pneumatic tubes may damage the robot system and/or work piece as the work piece is released when the Emergency Stop switch is pressed. I/O outputs are configured at the factory so that they are automatically shut off (0) by power disconnection, the Emergency Stop switch, or the safety features of the robot system.</p>
---	---

Wrist Flange

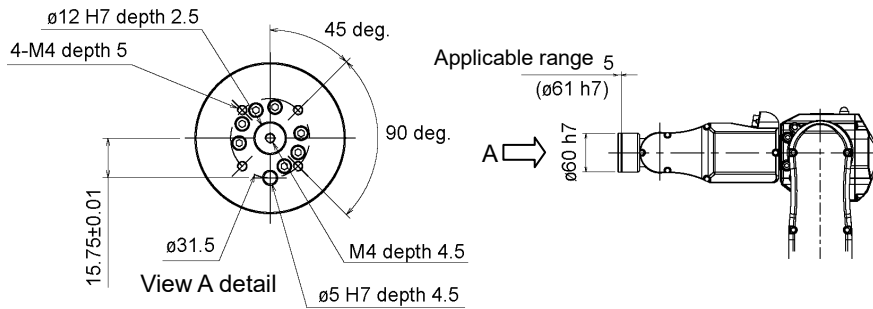

Arm #6

Attach an end effector to the end of the Arm #6 using the M4 bolts.

Layouts

When you operate the Manipulator with an end effector, the end effector may interfere with the Manipulator body depending on the outer diameter of the end effector, the size of the work piece, or the position of the arms. When designing your system layout, pay close attention to the interference area of the end effector.

Compatibility with PS series:

To install the end effector used in the PS series to the C4 series, we provide the optional PS Compatible Plate. For details, refer to *Setup & Operation: 6. Options.*

4.2 Attaching Camera and Air Valves

Decks are equipped to Arms #3 and #5 to enable the easy installation of air valve.

If the payload exceeds the maximum payload, refer to the section “*Restriction on payload exceeding the maximum payload*” in the *Setup & Operation 4.3.1 WEIGHT Setting*.

To mount the camera, the camera plate unit is necessary.

We provide the optional Camera Plate Unit. For details, refer to *Setup & Operation: 6. Options*.

[Unit: mm]

C4-A601**

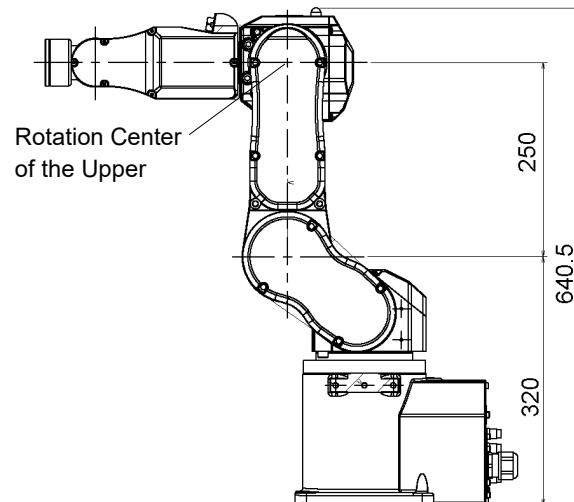
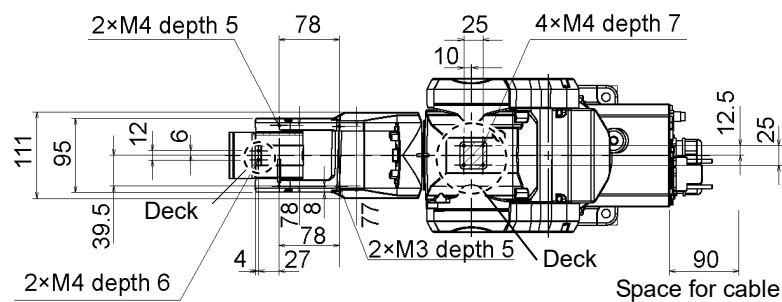

C4-A901**

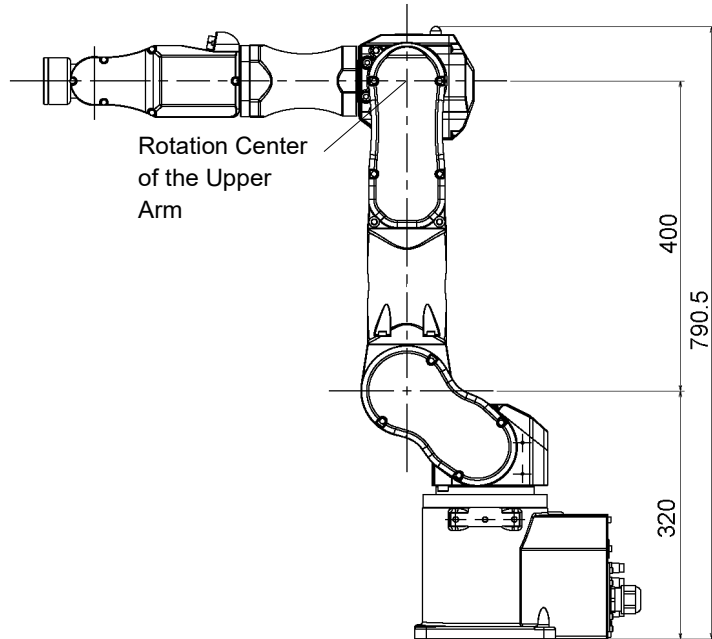
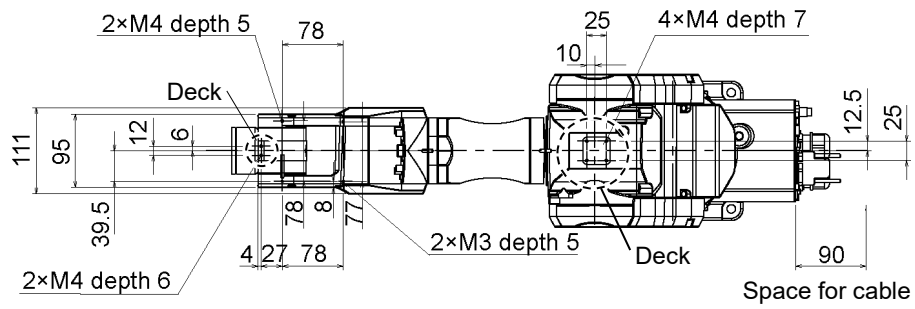

4.3 WEIGHT and INERTIA Settings

The WEIGHT and INERTIA commands are for setting the load parameters of the Manipulator. These settings optimize the Manipulator motion.

WEIGHT Setting

The WEIGHT command is for setting the load weight. The more the load weight increases, the more the speed and acceleration/deceleration are reduced.

INERTIA Setting

The INERTIA command is for setting the inertia moment and the eccentricity of the load. The more the inertia moment increases, the more the acceleration and deceleration of the Arm #6 are reduced. The more the eccentricity increases, the more the acceleration and deceleration for the Manipulator movement are reduced.

To ensure optimum Manipulator performance, make sure that the load (weight of the end effector and work piece) and inertia moment of the load are within the maximum rating for the Manipulator, and that Arm #6 does not become eccentric.

If the load or the inertia moment exceeds the ratings or if the load becomes eccentric, follow the steps in the *Setup & Operation 4.3.1 WEIGHT Setting* and *4.3.2 INERTIA Setting*, to set parameters.

Setting parameters makes the operation of the Manipulator optimal, reduces vibration to shorten the operating time, and improves the capacity for larger loads. In addition, it reduces persistent vibration produced when the inertia moment of the end effector and work piece is bigger.

The allowable load for C4 series Manipulators is as follows:

Up to 4 (5) kg*

Due to the limitations shown in the tables below, the moment and the inertia moment should also meet these conditions.

If force is applied to the Manipulator instead of weight, it should not exceed the values shown in the table below.

* If the payload exceeds the maximum payload, refer to the section “*Restriction on payload exceeding the maximum payload*” in the *Setup & Operation 4.3.1 WEIGHT Setting*.

Allowable Load

Joint	Allowable Moment *1	GD ² /4 Allowable Moment of Inertia
#4	4.41 N·m (0.45 kgf·m)	0.15 kg·m ²
#5 *2	4.41 N·m (0.45 kgf·m)	0.15 kg·m ²
#6	2.94 N·m (0.3 kgf·m)	0.1 kg·m ²

*1 Torque unit

*2 The allowable load for Arm #5 are calculated as follows:

Distance from the center of Arm #5 rotation (Figure: a + 65 [mm]).

Critical Dimension of Load

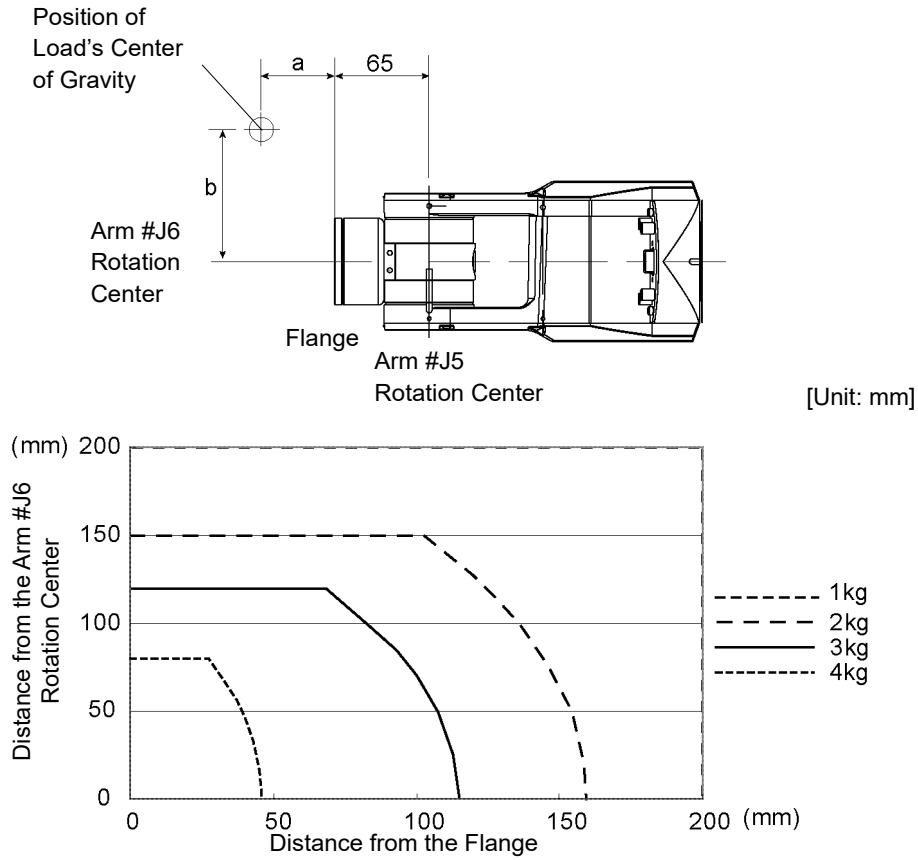

When calculating the critical dimension of the load on the Arm #5 using the allowable moment and inertia moment, the calculated value represents a distance from the Arm #5 rotation center, not the distance from the flange. Therefore, to get a value of the critical dimension of the load on Arm #5, subtract 65 (mm) from the calculated distance as shown in the example below.

Example: Calculate the critical dimension of the load on the Arm #5 (c) when a 2.5 kg load is on the Arm #6 rotation center line (b = 0).

$$\begin{aligned} & \text{Allowable Moment of the Arm \#5 (N}\cdot\text{m)} / \text{Load (kg)} \\ & = \text{Distance from the Arm \#5 rotation center (m)} \\ & 4.41 \text{ (N}\cdot\text{m)} / 9.8 / 2.5 \text{ (kg)} = 0.18 \rightarrow 0.18 \text{ (m)} = 180 \text{ (mm)} \end{aligned}$$

$$\begin{aligned} c &= \text{Distance from the Arm \#5 rotation center (mm)} - 65 \text{ (mm)} \\ c &= 180 \text{ (mm)} - 65 \text{ (mm)} = 115 \text{ (mm)} \end{aligned}$$

Moment

A moment is a necessary torque (holding torque) to counteract the gravity affecting the load. Design an end effector so that the eccentric quantity at the position where the load is attached is within the allowable moment.

A maximum torque (T) is calculated by the following formula.

$$T = m \text{ (kg)} \times L \text{ (m)} \times g \text{ (m/s}^2\text{)}$$

m: Weight of load (kg)

L: Eccentric quantity of load (m)

g: Gravitational acceleration (m/s²)

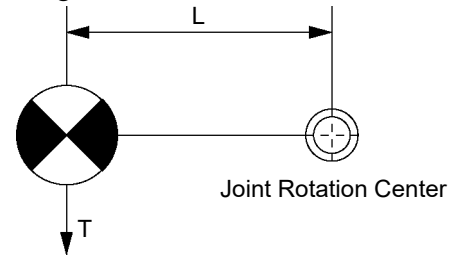

Max. Eccentric Quantity of Load

(Distance between the joint rotation center and the load's center of gravity)

Axis	WEIGHT 1 kg	WEIGHT 2 kg	WEIGHT 2.5 kg	WEIGHT 3 kg
#4	200 mm	200 mm	150 mm	112 mm
#5	200 mm	200 mm	150 mm	112 mm
#6	200 mm	150 mm	100 mm	75 mm

(The maximum eccentric quantity of load is restricted to 200 mm or less.)

4.3.1 WEIGHT setting



CAUTION

- Set the total weight of the end effector and the work piece smaller than the maximum payload.

The C4 Manipulators can operate without limitations on the condition unless and until the load exceeds this maximum payload. When the payload of the Manipulator exceeds the maximum payload, refer to the section “*Restrictions on payload exceeding the maximum payload*” in the later part of this section for details.

Always set the Weight parameters of the WEIGHT command according to the load. Setting a value that is smaller than the actual load may cause errors, excessive shock, insufficient function of the Manipulator, and/or shorten the life cycle of parts/mechanisms.

The acceptable weight capacity (end effector and work piece) for C4 Manipulators is as follows:

Rated	Maximum
1 kg	4(5) kg*

When the load exceeds the rating, change the setting of the Weight parameter.

After changing the Weight parameter setting, the maximum acceleration/deceleration and speed of the robot system corresponding to the load is set automatically.

* If the payload exceeds the maximum payload, refer to the section “*Restriction on payload exceeding the maximum payload*” in the *Setup & Operation 4.3.1 WEIGHT Setting*.



Setting method of Weight parameters

Select [Tools]-[Robot Manager]-[Weight] panel and set the value in [Weight:].
 You may also execute the Weight command from [Command Window].

Load on the Manipulator

Mounting location of the load

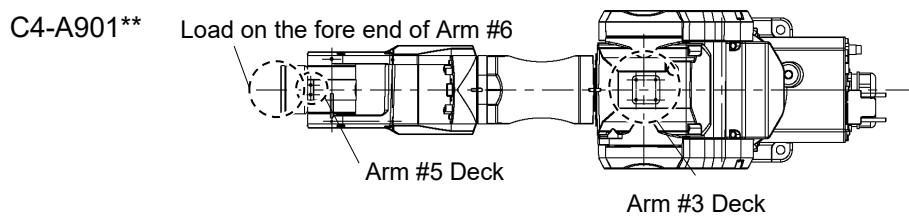
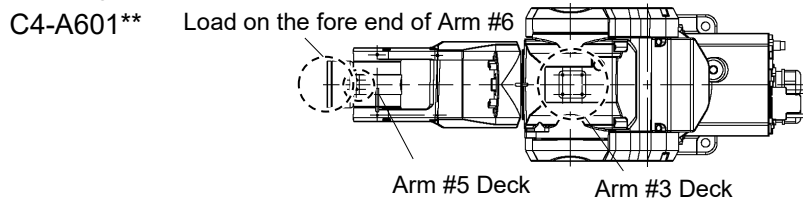

C4 series

Deck detailed

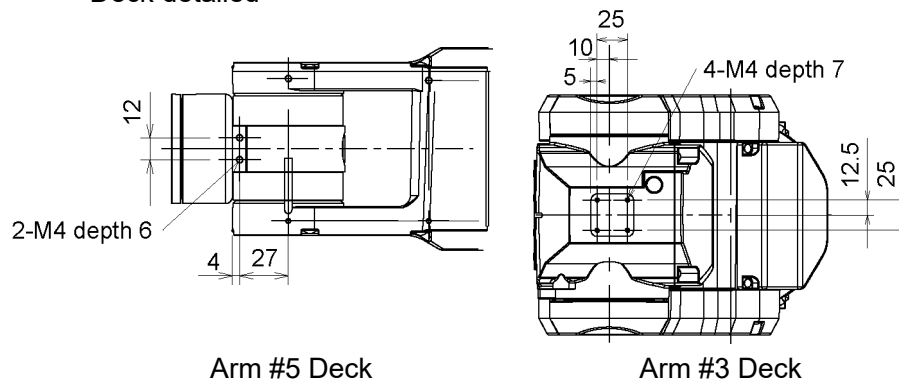

[Unit: mm]

When you attach the equipment to the decks on the upper arm, convert its weight into equivalent weight assuming that the equipment is attached to the end of the Arm #6. Then, this equivalent weight added to the load will be a Weight parameter.

Calculate the Weight parameter by using the formula below and enter the value.

Weight Parameter Formula

$$\text{Weight parameter} = M_w + W_a + W_b$$

M_w : Load on the fore end of Arm #6 (kg)

W_a : Equivalent weight of the Arm #3 deck (kg)

W_b : Equivalent weight of the Arm #5 deck (kg)

$$W_a = M_a (L_a)^2 / (L)^2$$

$$W_b = M_b (L_b)^2 / (L)^2$$

M_a : Weight of the air valve on the Arm #3 deck

M_b : Weight of the camera on the Arm #5 deck

L : Length of the upper arm (315 mm)

L_a : Distance between the Joint #3 and the center of gravity of the air valve on the Arm #3 deck (mm)

L_b : Distance between the Joint #3 and the center of gravity of the camera on the Arm #5 deck (mm)

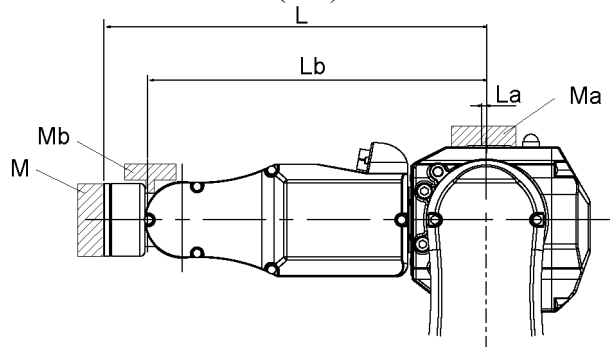

<Example> The fore end of the Arm #6 is 315 mm (L) away from the Joint #3.

Load on the fore-end of Arm #6 is 1 kg (M_w).

Load on the Arm #3 deck is 1.5 kg (M_a).

The deck is 0 mm (L_a) away from Joint #3.

Load on the Arm #5 deck is 0.5 kg (M_b).

The deck is 280 mm (L_b) away from the Joint #3.

$$W_a = 1.5 \times 0^2 / 315^2 = 0$$

$$W_b = 0.5 \times 280^2 / 315^2 = 0.395 \rightarrow 0.4 (\text{round up})$$

$$M_w + W_a + W_b = 1 + 0 + 0.4 = 1.4$$

Enter "1.4" for the Weight parameter.

Automatic speed setting by Weight parameter (C4-A601**)

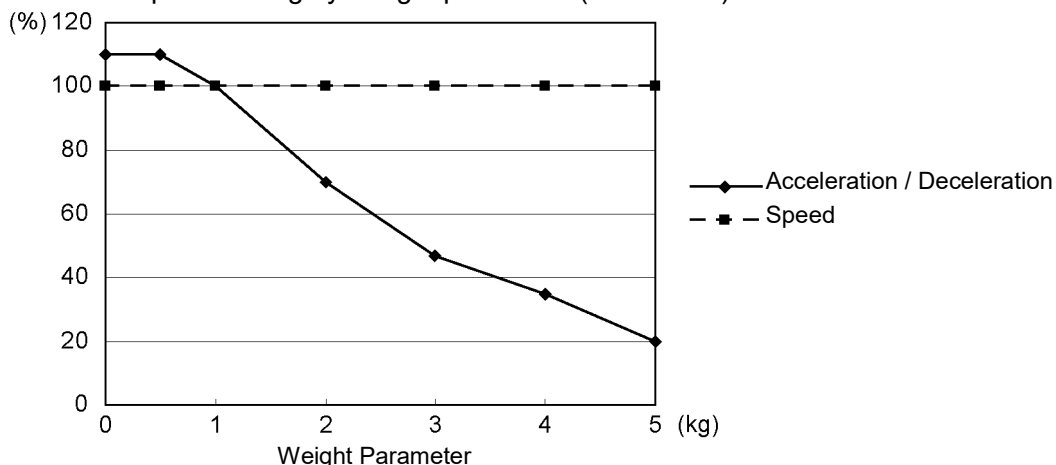

Automatic speed setting by Weight parameter (C4-A901**)

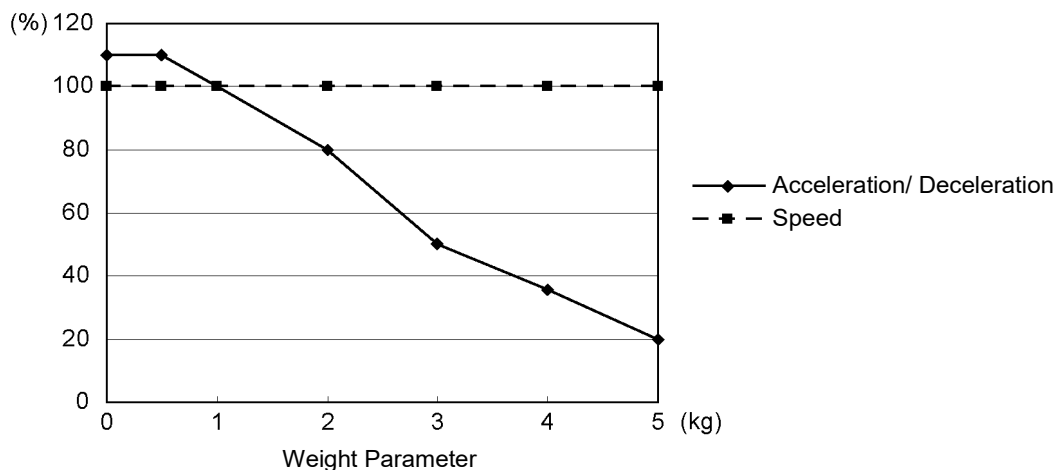

* The percentage in the graph is based on the speed at rated weight (1 kg) as 100%.

* If the payload exceeds the maximum payload, refer to the section “*Restriction on payload exceeding the maximum payload*” in the *Setup & Operation 4.3.1 WEIGHT Setting*.

Restrictions on payload exceeding the maximum payload

Maximum payload for C4 Manipulators is as follows:

Payload can be increased by restricting the arm posture of the Arm #5 downward.

Max. Payload	Max. Payload with Pose Restriction
4 kg	5 kg

If the load exceeds the maximum payload, use the Arm #5 with a posture angle within the range indicated in the following graph.

The graph shows the relation of the load weight and Arm #5 angle limit (A^1) measured in vertical direction (direction of gravity). Note that the heavier the load on the Arm #6, the smaller the angle limit becomes.

When the Manipulator operates vertically to the operating surface, the limit of the Arm #5 is equivalent to the limit of the operating angle (A^2).

In addition, for the eccentric load, the angle limit is an angle of the line joining the center of the load and the Arm #5 rotation axis with the vertical direction (B).

The eccentric quantity of the load should be within the allowable moment and inertia moment of Arms #4, #5, and #6.

Relation of load weight and Arm #5 angle limit

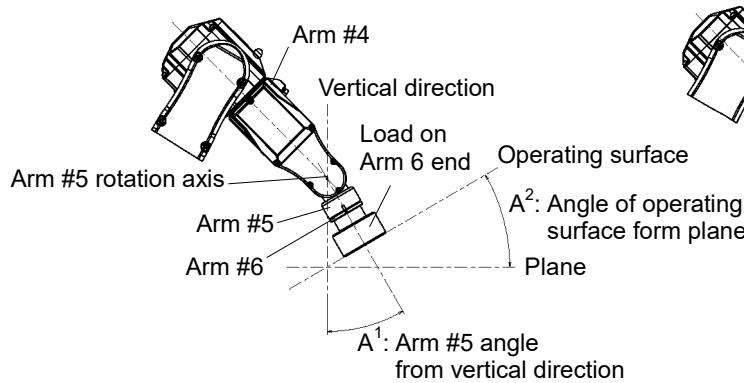
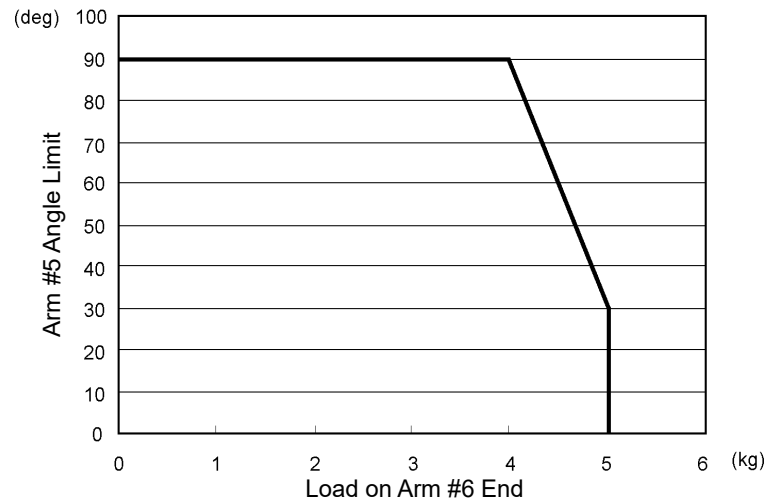

Relation of Arm #5 angle and operating surface

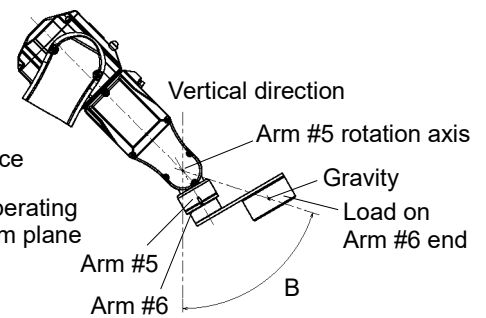

Angle limit for eccentric load

4.3.2 INERTIA setting

Inertia Moment and the INERTIA Setting

The inertia moment is defined as “the ratio of the torque applied to a rigid body and its resistance to motion”. This value is typically referred to as “the moment of inertia”, “inertia”, or “GD²”. When the Manipulator operates with objects such as an end effector attached to the Arm #6, the moment of inertia of load must be considered.



CAUTION

- The inertia moment of the load (weight of the end effector and work piece) must be 0.1 kg·m² or less. The C4 Manipulators are not designed to work with inertia moment exceeding 0.1 kg·m².
Always set the inertia moment (INERTIA) parameter according to the inertia moment. Setting a value that is smaller than the actual inertia moment may cause errors, excessive shock, insufficient function of the Manipulator, and/or shorten the life of parts/mechanisms.

The acceptable inertia moment of load for C4 Manipulator is 0.005 kg·m² nominal rating and 0.1 kg·m² maximum. When the inertia moment of the load exceeds the rating, change the setting of the inertia moment using the INERTIA command. After the setting has been changed, the maximum acceleration/deceleration speed of Arm #6 responding to “inertia moment” is set automatically.

Inertia moment of load on Arm #6

The inertia moment of the load (weight of the end effector and work piece) on the Arm #6 can be set by the “inertia moment (INERTIA)” parameter of the INERTIA command.

EPSON
RC+

Select [Tools]–[Robot Manager]-[Inertia] panel and enter the value in [Load inertia:].
You may also execute the Inertia command from [Command Window].

Eccentric Quantity and the INERTIA Setting



- The eccentric quantity of the load (weight of the end effector and work piece) must be 200 mm or less. The C4 Manipulators are not designed to work with eccentric quantity exceeding 200 mm. Always set the eccentric quantity parameter according to the eccentric quantity. Setting a value that is smaller than the actual eccentric quantity may cause errors, excessive shock, insufficient function of the Manipulator, and/or shorten the life cycle of parts/mechanisms.

The acceptable eccentric quantity of the load for C4 Manipulators is 30 mm at nominal rating and 200 mm at maximum. When the eccentric quantity of the load exceeds the rating, change the setting of eccentric quantity parameter using the INERTIA command. After changing the setting, the maximum acceleration/deceleration speed of Manipulator corresponding to “eccentric quantity” is set automatically.

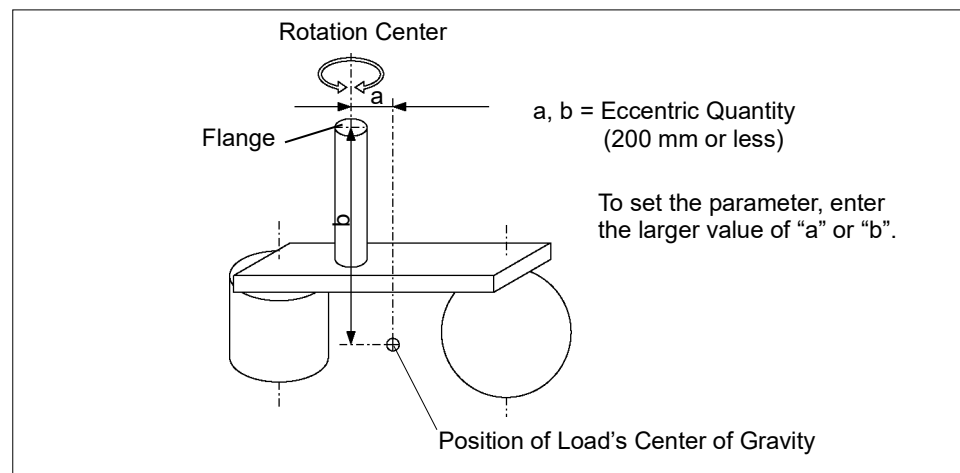

Eccentric Quantity

Eccentric quantity of load on Arm #6

The eccentric quantity of the load (weight of the end effector and work piece) on the Arm #6 can be set by the “eccentric quantity” parameter of the INERTIA command. Enter the larger value of either “a” or “b” in the figure above to [Eccentricity].



Select [Tools]–[Robot Manager]–[Inertia] panel and enter the value into [Eccentricity:]. You may also execute the Inertia command from [Command Window].

Automatic acceleration/deceleration setting by INERTIA (eccentric quantity)

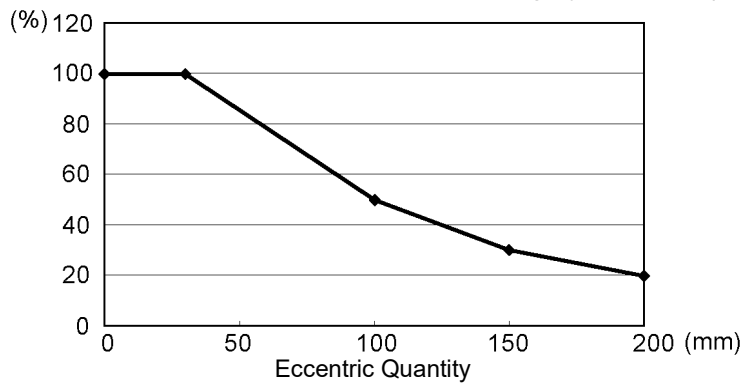

* The percentage in the graph is based on the acceleration/ deceleration at rated eccentricity (30 mm) as 100%.

INERTIA (eccentric quantity) is affected by the load setting. Refer to *Setup & Operation 4.3: WEIGHT and INERTIA Settings* and configure the load setting carefully.

Calculating the Inertia Moment

Refer to the following example formulas to calculate the inertia moment of the load (end effector with work piece).

The inertia moment of the entire load is calculated by the sum of (a), (b), and (c).

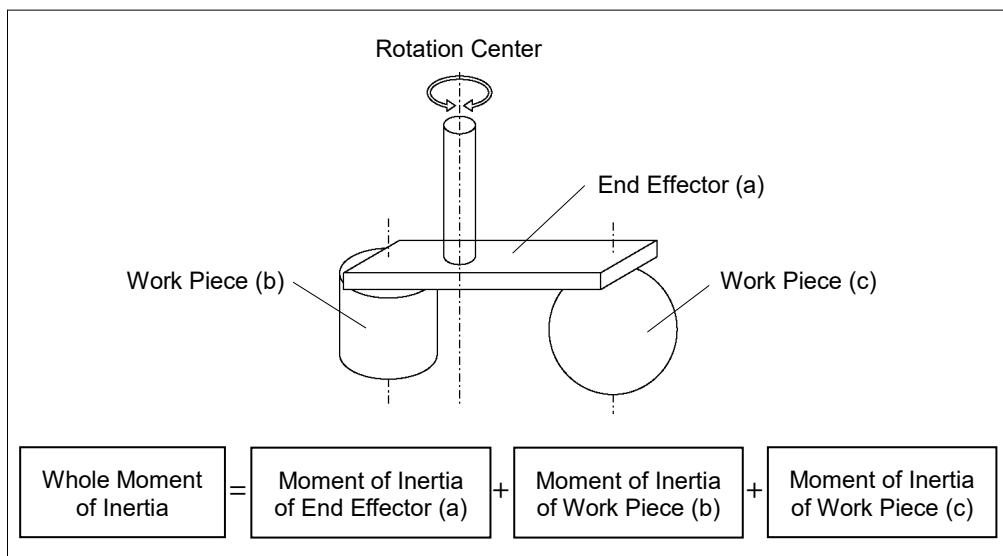

The methods for calculating the inertia moment for (a), (b), and (c) are shown in this and the next page. Figure out the whole inertia moment using the basic formulas below.

(a) Inertia moment of a rectangular parallelepiped

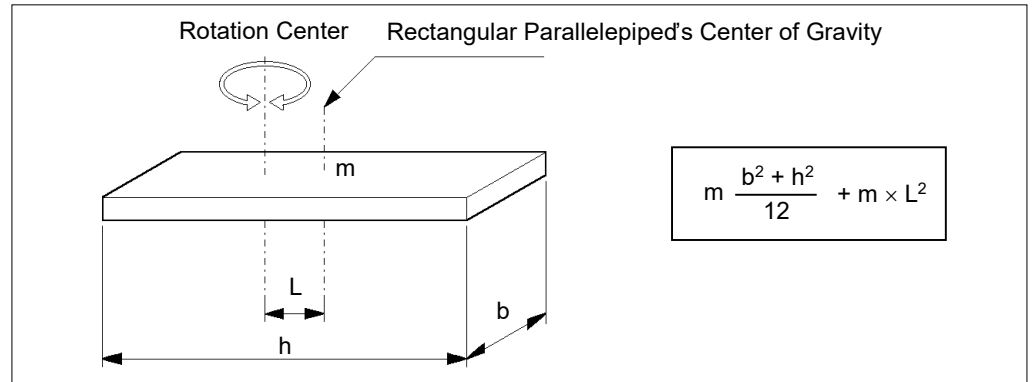

(b) Inertia moment of a cylinder

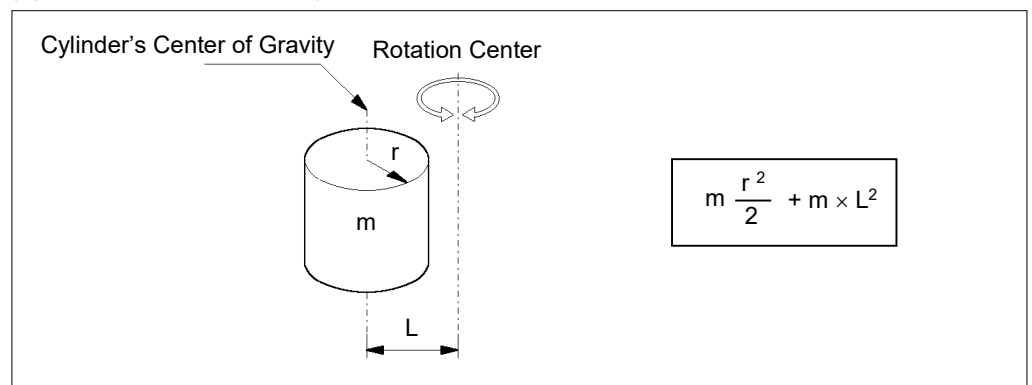

(c) Inertia moment of a sphere

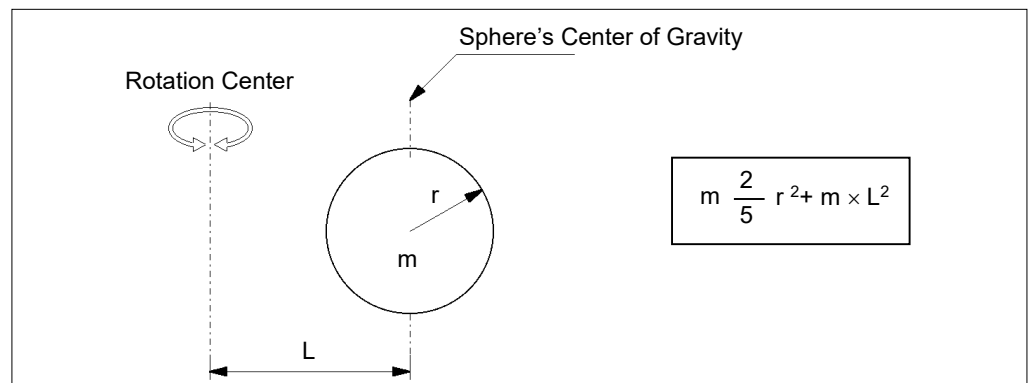

4.4 Precautions for Auto Acceleration/Deceleration

The speed and acceleration/deceleration of the Manipulator motion are automatically optimized according to the values of WEIGHT and INERTIA and the Manipulator's postures.

WEIGHT Setting

The speed and acceleration/deceleration of the Manipulator are controlled according to the load weight set by the WEIGHT command.

The more the load weight increases, the more the speed and acceleration/deceleration are reduced to prevent residual vibration.

INERTIA Setting

The acceleration/deceleration of Arm #6 are controlled according to the inertia moment set by the INERTIA command. The acceleration/deceleration of the whole Manipulator are controlled according to the eccentricity set by the INERTIA command. The more the inertia moment and eccentricity of the load increase, the more the acceleration/deceleration are reduced.

Auto Acceleration/Deceleration According to Manipulator's Posture

The acceleration/deceleration are controlled according to the Manipulator's posture. When the Manipulator extends its arms or when the movement of the Manipulator produces vibration frequently, the acceleration/deceleration are reduced.

Set appropriate values for WEIGHT and INERTIA so that the Manipulator operation is optimized.

5. Motion Range



WARNING

- When limiting the motion range for safety, be sure to set by both the pulse range and mechanical stops. Failure to do so may cause serious safety problems.

The motion range is preset at the factory as describes in the *Setup & Operation 2.5 Standard Motion Range*. This is the maximum motion range of the Manipulator.

Motion range is set by the following three methods:

1. Setting by pulse range (for all arms)
2. Setting by mechanical stops
3. Setting the Cartesian (rectangular) range in the X, Y coordinate system of the Manipulator

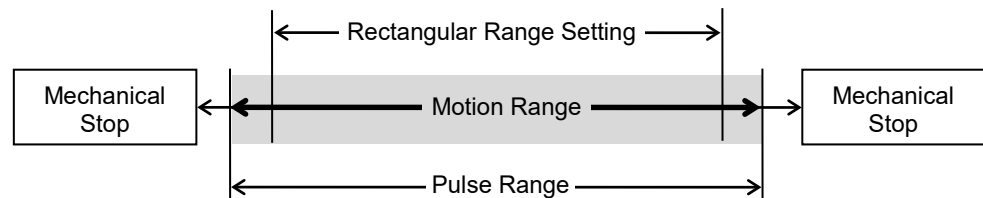

When the motion range is changed due to layout efficiency or safety, follow the descriptions in 5.1 through 5.4 to set the range.

5.1 Motion Range Setting by Pulse Range (for All Arms)

Pulses are the basic unit of Manipulator motion. The motion range of the Manipulator is controlled by the pulse range (the lower limit and the upper limit) of each axis.

Pulse values are read from the encoder output of the servo motor.

The pulse range should be set within the mechanical stop range.



- Do not set and/or use the Arm #4 with a pulse range exceeding the maximum value.
The Arm #4 does not have a mechanical stop. Using the Arm #4 with a pulse range exceeding the maximum pulse range may cause the inner wiring damaged and/or malfunction to the Manipulator.

Torsion of the inner wiring can be checked by removing the Arm #3 head cover.

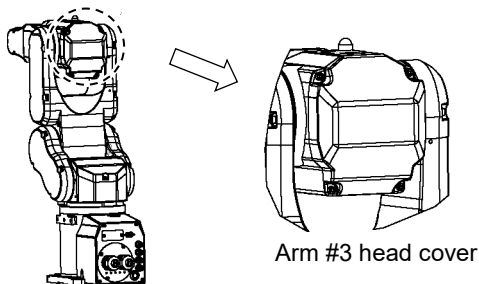

Once the Manipulator receives an operating command, it checks whether the target position specified by the command is within the pulse range before operating. If the target position is out of the set pulse range, an error occurs and the Manipulator does not move.



The pulse range can be set in [Tools]-[Robot manager]-[Range] panel.
You may also execute the Range command from the [Command Window].

5.1.1 Max. Pulse Range of Arm #1

Pulse values in counterclockwise direction are positive (+) and values in clockwise direction are negative (-).

C4-A601**

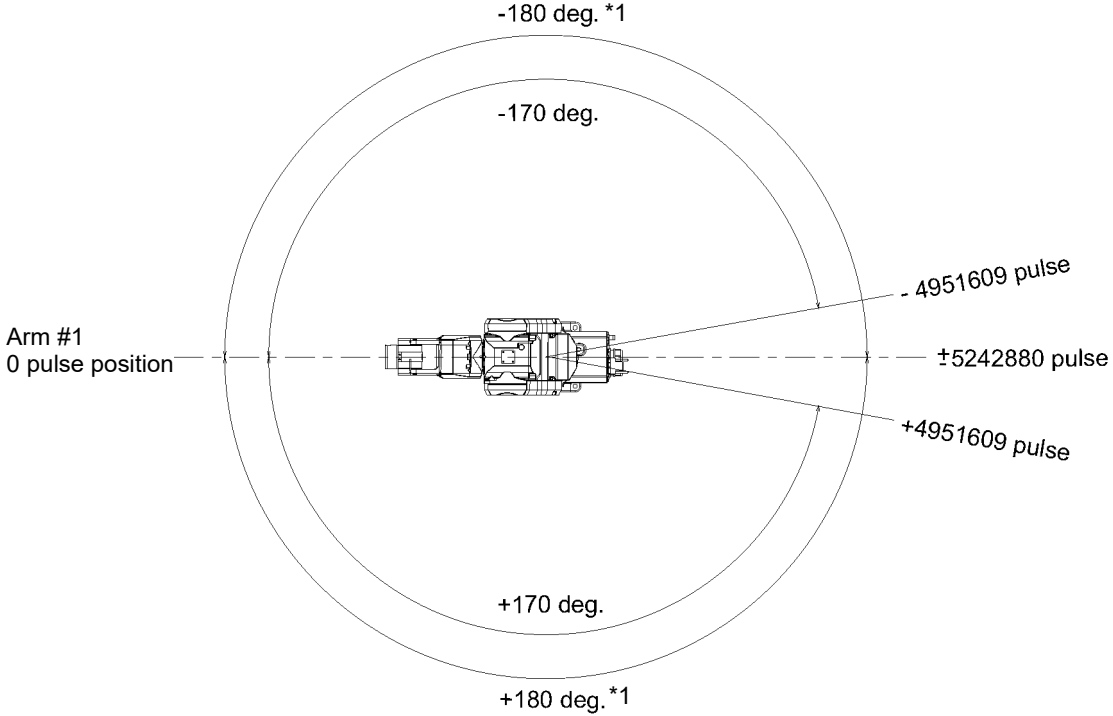

C4-A901**

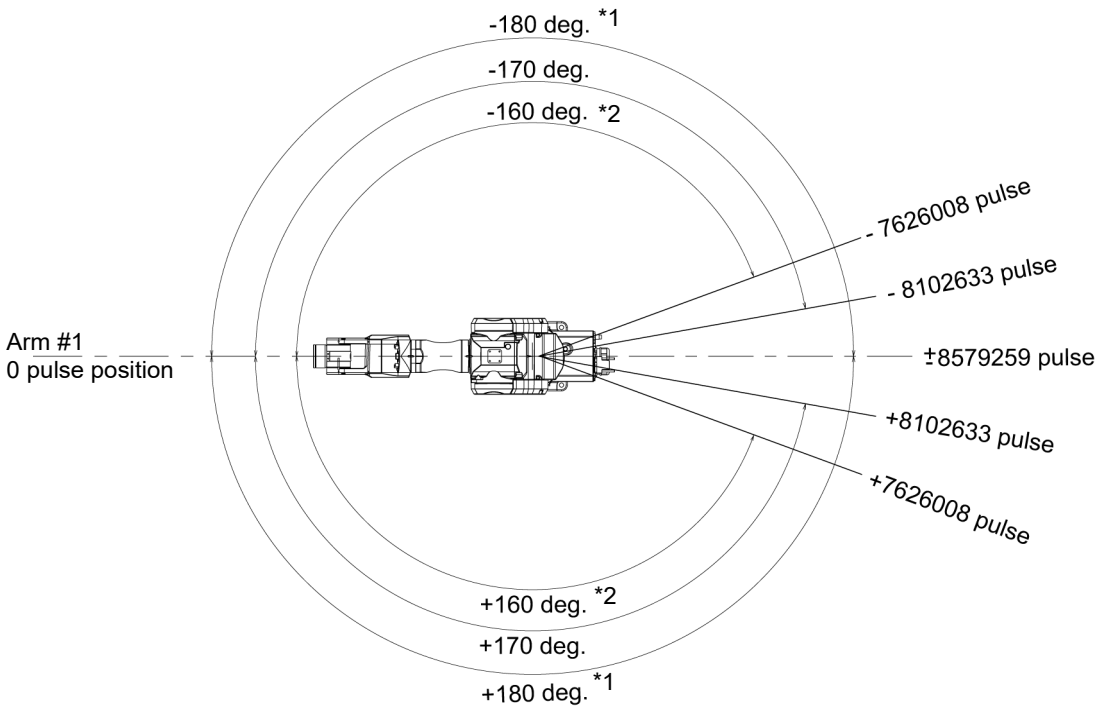

*1 without mechanical stop

*2 UL Specification

5.1.2 Max. Pulse Range of Arm #2

Pulse values in clockwise direction are positive (+) and values in counterclockwise direction are negative (-).

C4-A601**

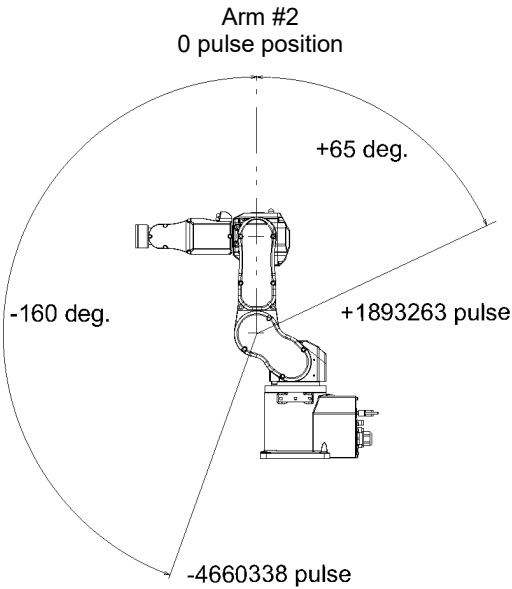

C4-A901**

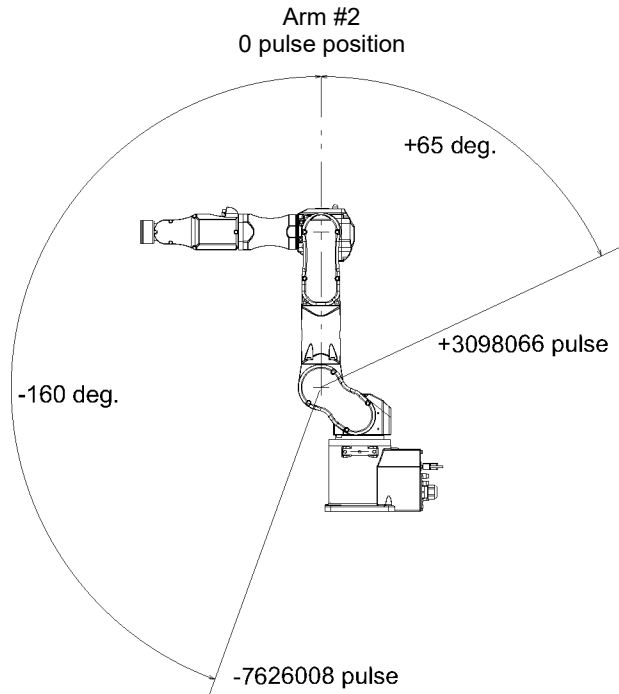

5.1.3 Max. Pulse Range of Arm #3

Pulse values in clockwise direction are positive (+) and values in counterclockwise direction are negative (-).

C4-A601**

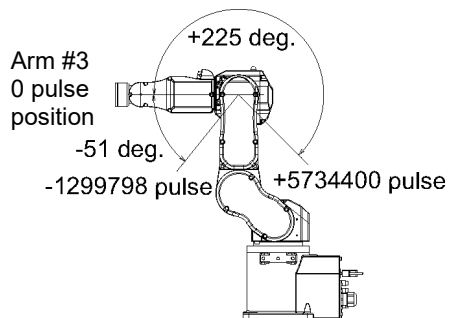

C4-A901**

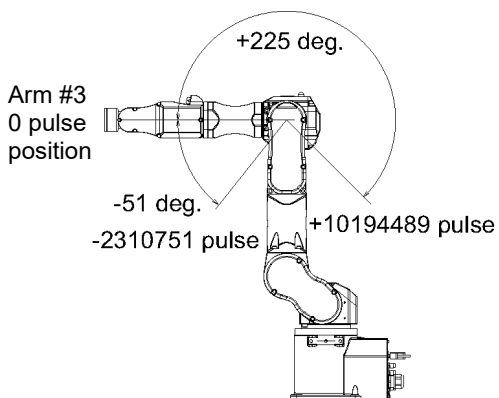

5.1.4 Max. Pulse Range of Arm #4

From the angle of arm end, clockwise pulse values are positive (+) and counterclockwise pulse values are negative (-).

C4-A601**

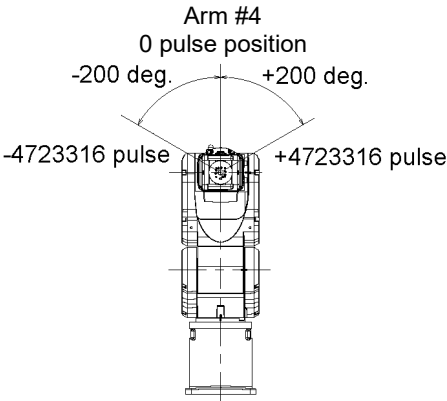

C4-A901**

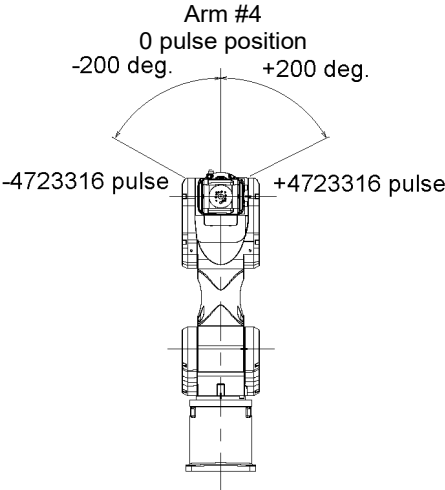

<p>CAUTION</p>	<ul style="list-style-type: none">Do not set and/or use the Arm #4 with a pulse range exceeding the maximum value. The Arm #4 does not have a mechanical stop. Using the Arm #4 with a pulse range exceeding the maximum pulse range may cause the inner wiring damaged and/or malfunction to the Manipulator.
----------------	--

Torsion of the inner wiring can be checked by removing the Arm #3 head cover.

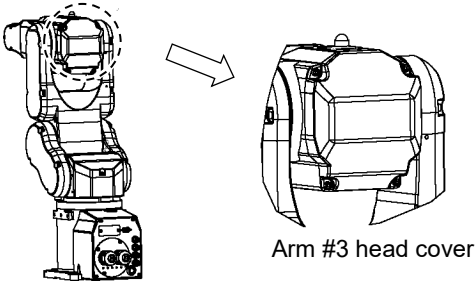

5.1.5 Max. Pulse Range of Arm #5

Pulse values in clockwise direction are positive (+) and values in counterclockwise direction are negative (-).

C4-A601**

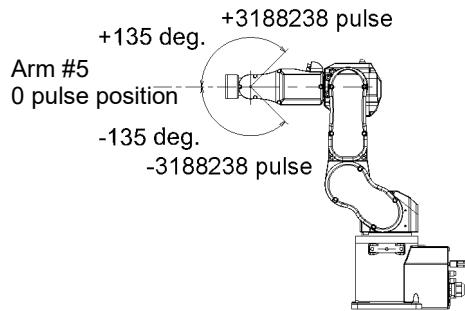

C4-A901**

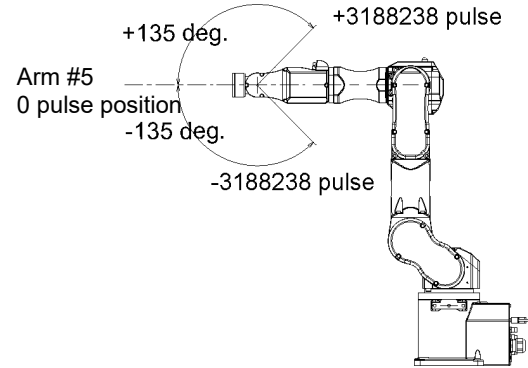

5.1.6 Max. Pulse Range of Arm #6

From the angle of arm end, clockwise pulse values are positive (+) and counterclockwise pulse values are negative (-).

C4-A601**

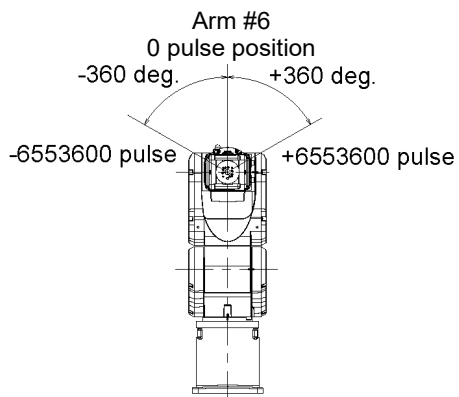

C4-A901**

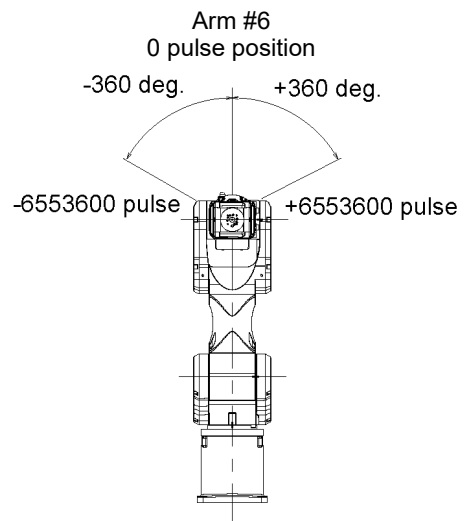

5.2 Motion Range Setting by Mechanical Stops

Mechanical stops physically limit the absolute area that the Manipulator can move.

Be sure to turn OFF the Controller in advance.

Use bolts conforming to the specified length and surface processing (ex: nickel plating) with high corrosion resistance.

Specify the pulse range again after changing the position of the mechanical stop.

For details on the pulse range setting, refer to the *Setup & Operation 5.1 Motion Range Setting by Pulse Range (for All Arms)*.

Be sure to set the pulse range not to exceed the setting angles of the mechanical stop.

5.2.1 Motion Range Setting of Arm #1

Install the bolt to the threaded hole corresponding to the angle you want to set.

Normally a mechanical stop is equipped at [b].

[a] and [c] limit the one side of motion range.

Remove the bolts when the motion range of the Arm #1 is set to $\pm 180^\circ$.

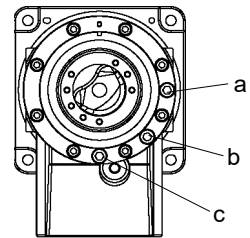

M8×15 hexagon socket head cap bolt

Tightening torque 37.2 N·m (380 kgf·cm)

		a	b		c
Angle (°)		-125	±170	±180	+125
Pulse (pulse)	C4-A601**	-3640889	±4951609	±5242880	+3640889
	C4-A901**	-5957819	±8102633	±8579259	+5957819
	C4-A901**-UL		±7626008		
Bolt		Applied	Applied (standard)	Not applied	Applied

Mechanical stop for UL specification

There is a specified mechanical stop for UL specification.

Mount the mechanical stop as shown in the figure below.

C4

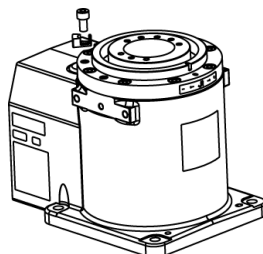

C4L

The setting angle differs from the non-UL compliant model. (refer to the above table)

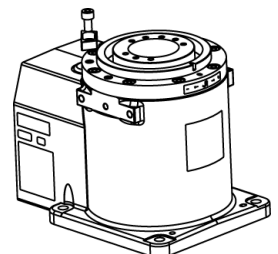

5.2.2 Motion Range Setting of Arm #2

There are threaded holes corresponding to each angle on the Manipulator.

Normally there is no mechanical stop equipped.
(-160 to +65°)

[d] and [e] limit the one side of motion range.

C4-A601**

M10×15 hexagon socket head cap bolt

Tightening torque 73.5 N·m (750 kgf·cm)

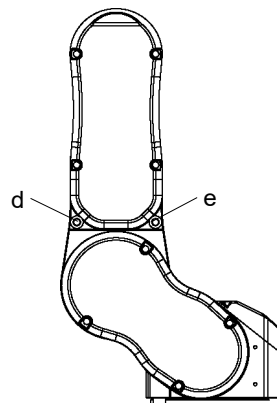

	d	e	-	-
Angle (°)	-143	+48	-160	+65
Pulse (pulse)	-4165177	+1398102	-4660338	+1893263
Bolt	Applied	Applied	Not applied (standard)	Not applied (standard)

For C4-A901**, please contact the supplier of your region.

5.2.3 Motion Range Setting of Arm #3

There are threaded holes corresponding to each angle on the Manipulator.

Normally mechanical stops are equipped to [f] and [g].
(+225° to -51°)

C4-A601**, C4-A901**

M8×12 hexagon socket head cap bolt

Tightening torque 37.2 N·m (380 kgf·cm)

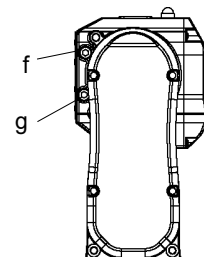

		f	g
Angle (°)		+225	-51
Pulse (pulse)	C4-A601**	+5734400	-1299798
	C4-A901**	+10194489	-2310751
Bolt		Applied (standard)	Applied (standard)

5.3 Restriction of Manipulator Operation by Joint Angle Combination

To prevent the arms of the Manipulator from interfering each other, the Manipulator operation is restricted in the specified motion range according to the joint angle combination of the Arm #1, #2, and #3.

The Manipulator operation is restricted and the Manipulator stops when the joint angles of the Arm are within the gray areas in the following figure.

The restriction to Manipulator operation is enabled:

- During CP motion command execution
- When you attempt to execute the motion command for moving the Manipulator to a target point (or pose) in the specified motion range.

The restriction to the Manipulator operation is disabled:

- The Arms of the Manipulator momentarily go through the specified motion range during the PTP motion command execution even though the joint angles of the Arms are in the gray areas of the figures above.

(deg.=°)

Combination of Joint #1 and #2 (C4-A601**)

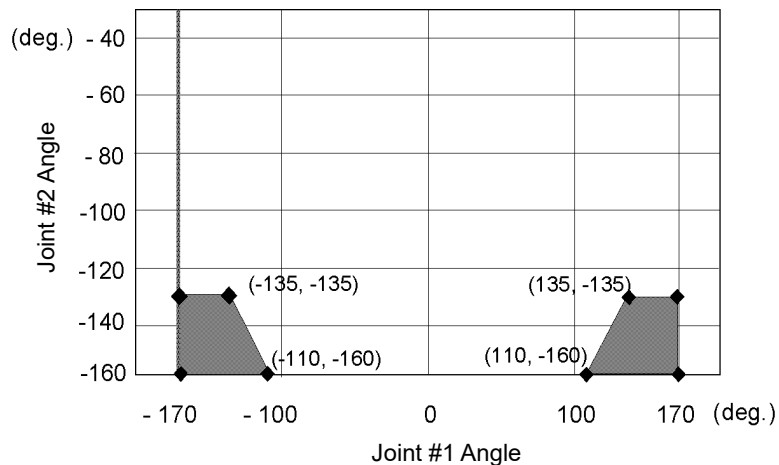

Combination of Joint #2 and #3 (C4-A601**)

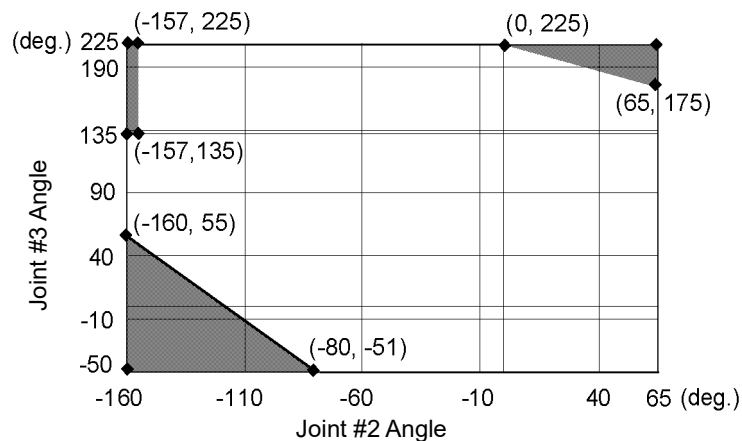

Combination of Joint #1 and #2 (C4-A901**)

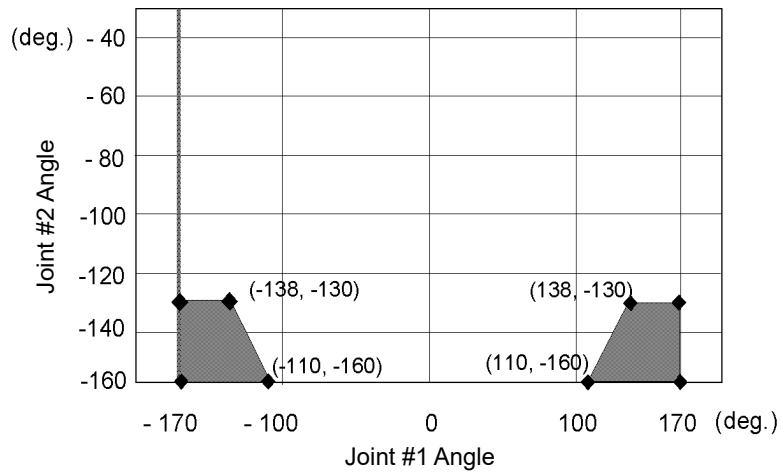

Combination of Joint #1 and #2 (C4-A901**-UL)

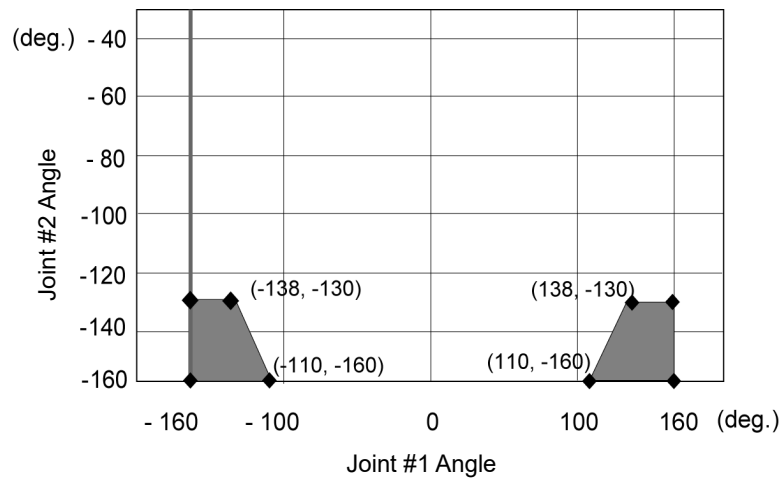

Combination of Joint #2 and #3 (C4-A901**)

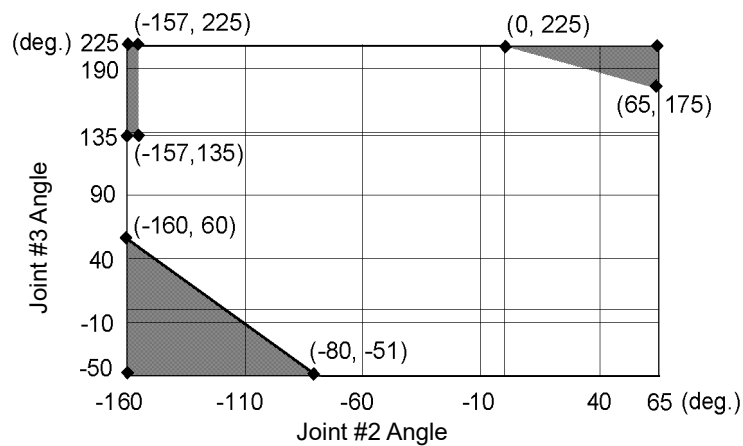

5.4 Coordinate System

The origin point is where the Manipulator base intersects with the rotation axis of Joint #1.
 For details on the coordinate system, refer to the *EPSON RC+ Users Guide manual*.

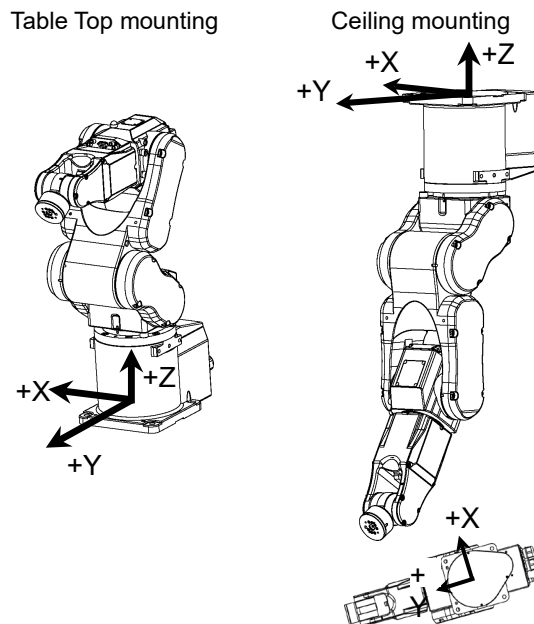

BASE setting is suitable for install the robot obliquely.

BASE setting can change a specific coordinate system of the robot and match the World coordinate system of the Jog & Teach and the coordinate system of the equipment.

For procedure of the BASE setting, refer to *SPEL+ Language Reference: BASE Command*.

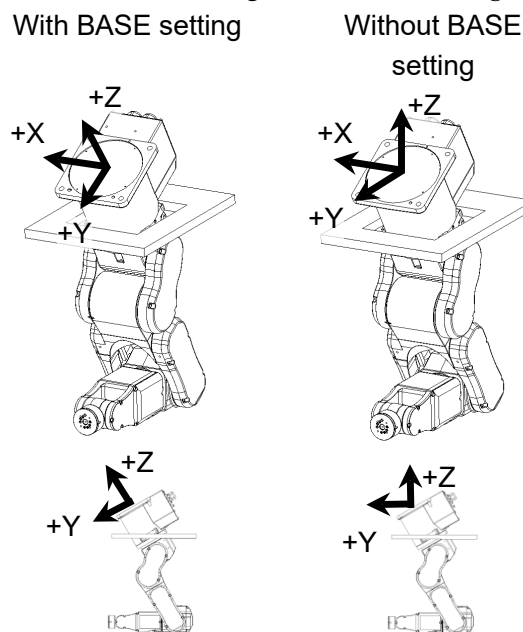

5.5 Changing the Robot

This section describes how to change the Manipulator model on EPSON RC+.
(Default setting is “table top mounting”.)

 CAUTION	<p>■ Changing the Manipulator should be done with great caution. It initializes the robot calibration parameters (Hofs, CalPIs), additional axis information, and PG parameter data. Before changing the robot, make sure to save the calibration data by following the procedure below.</p> <ol style="list-style-type: none"> 1. Select the EPSON RC+ 7.0 menu-[Setup]-[System Configuration]. 2. Select [Controller]-[Robots]-[Robot**]-[Calibration] from the tree list. Then, click <Save>.
---	--

(1) Select the EPSON RC+ 7.0 menu-[Setup]-[System Configuration].

(2) Select [Controller]-[Robots]-[Robot**] from the tree list.



(3) Click the <Change...> button. The following dialog box will be displayed.

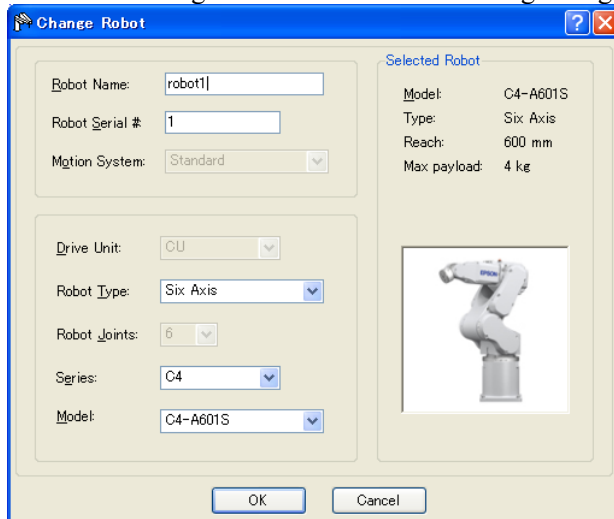

(4) Input the robot name and serial number printed on the name plate of the Manipulator. Any serial number can be entered. However, enter the number printed on the Manipulator.

(5) Select the robot type in the [Robot type] box.

- (6) Select the series name of the Manipulator in the [Series] box.
- (7) Select the robot model in the [Model] box. Available robots will be displayed according to the format of the currently installed motor driver. When [Dry run] is used, all the Manipulators of the series selected in Step 6 will be displayed.
For the ceiling mount type, select the model which ends with “R” (e.g. C4-A601SR).
- (8) Click the <OK> button. The Controller will be restarted.

5.6 Setting the Cartesian (Rectangular) Range in the XY Coordinate System of the Manipulator

The Cartesian (rectangular) range in the XY coordinate system of the Manipulator is specified by the limited Manipulator operation area and the XYLIM setting.

The limited Manipulator operation area is defined so that the end effector does not interfere with the rear side of the Manipulator. The XYLIM setting that you can determine the upper and lower limits of the X and Y coordinates.

The limited Manipulator operation area and the XYLIM setting apply only to the software. Therefore, these settings do not change the physical range. The maximum physical range is based on the position of the mechanical stops.

These settings are disabled during a joint jogging operation. Therefore, be careful not to allow the end effector to collide with the Manipulator or peripheral equipment.

The method for changing the XYLIM setting varies with the software used.

EPSON
RC+

Set the XYLIM setting in [Tools]-[Robot manager]-[XYZ Limits] panel.
You may also execute the XYLim command from the [Command Window].

6. Options

C4 series Manipulator has the following options.

- 6.1 Brake Release Unit
- 6.2 Camera Plate Unit
- 6.3 PS Compatible Plate (Tool Adapter)
- 6.4 Base Side Angled Fittings
- 6.5 Base Side Fittings
- 6.6 PS Compatible Plate (Base Adapter)
- 6.7 Adjustable Mechanical Stop (Joint #2: Only C4-A901**)

6.1 Brake Release Unit

With the electromagnetic brake is ON (such as in Emergency Stop status), all arms don't move.

You can move the Arms by hand using the brake release unit while the Controller power is OFF or right after unpacking.

 WARNING	<ul style="list-style-type: none"> ■ When connecting / replacing the brake release unit or the external short connector, turn OFF the power to the Controller and the brake release unit. Inserting and removing the connector while the power is ON may result in electrical shock.
--	---

 CAUTION	<ul style="list-style-type: none"> ■ Normally, release the brake of joints one by one. Take extra care if you need to release the brakes of two or more joints simultaneously. Releasing the brakes of two or more joints simultaneously may cause hands and fingers to be caught and/or equipment damage to or malfunction of the Manipulator as the arms of the Manipulator may move in unexpected directions. ■ Be careful of the arm falling when releasing the brake. While the brake is being released, the Manipulator's arm falls by its own weight. The arm falling may cause hands and fingers to be caught and/or may cause equipment damage to or malfunction of the Manipulator.
--	---

Width	180 mm
Depth	150 mm
Height	87 mm
Weight (Cables are not included.)	1.7 kg
Cable to the Manipulator	2 m
Power cable length	2 m
Power cable (US)	100 V specification
Power cable (EU)	200 V specification

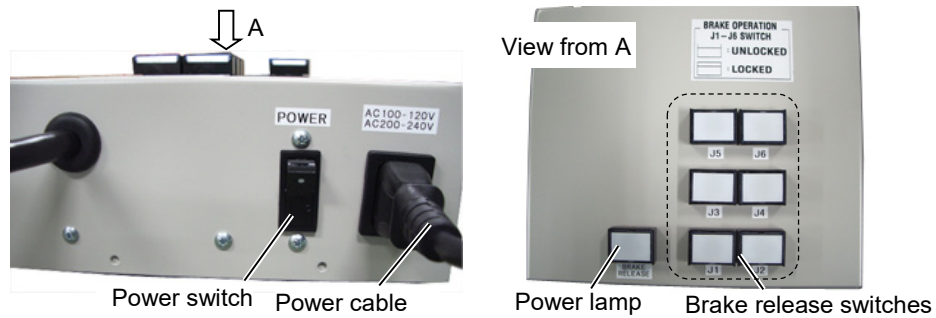

Precautions for use



CAUTION

- After the brake release unit is disconnected, be sure to connect the external short connector. Otherwise, you cannot release the brakes.
If the Manipulator is operated without connecting the brake release unit and the external short connector, the brakes cannot be released and it may cause damage on them. After using the brake release unit, be sure to connect the external short connector to the Manipulator, or check connection of the connector for the brake release unit.
- Keep the external short connector.
Otherwise you cannot release the brakes.
- If you turn ON the brake release unit while the brake release switch is being pressed, an unintended arm may move downward.
Before turning ON the brake release unit, make sure that the brake release switch is not pressed.
- If you turn ON the brake release unit without the connector, it may lead to the short for the male pin used in the connector.
Before turning ON the brake release unit, make sure that the connector is connected.

Mount the brake release unit

- (1) Turn OFF the Controller.
- (2) Remove the external short connector.

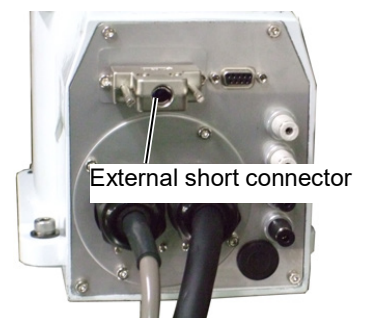

- (3) Connect the brake release unit to the connector of the connection cable.

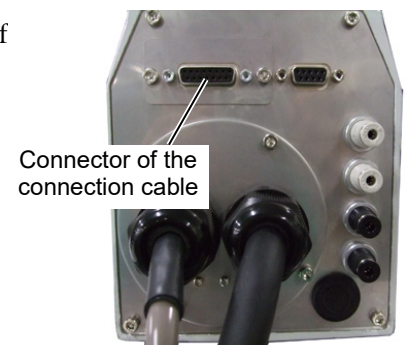

Remove the brake release unit

- (1) Turn OFF the brake release unit.
- (2) Remove the power cable of the brake release unit.
- (3) Disconnect the brake release unit from the connector of the connection cable.
- (4) Connect the external short connector to the connector of the connection cable.

How to use the brake release unit



- Be careful of the arm falling when releasing the brake.
While the brake is being released, the Manipulator's arm falls by its own weight. The arm falling may cause hands and fingers to be caught and/or may cause equipment damage to or malfunction of the Manipulator.
- If the arm you released its brake moves awkwardly or faster than usual, stop the operation promptly and contact the supplier of your region. The brake release unit may be broken.
If you keep operating the Manipulator, it may lead to the breakdown of the Manipulator or you may get your hand or fingers caught.



Power switch Power cable



Power lamp Brake release switches

- (1) Disconnect the external short connector.
- (2) Plug the power cable into the brake release unit.
- (3) Plug the power cable into the power supply plug.
- (4) Turn ON the brake release unit.
When the brake release unit is enabled, the power lamp lights up.
- (5) Press the switch of the arm (J1 to J6) you want to move and then move the arm.
Press the switch again. The brake will be released.
The brake will be enabled by pressing the switch once again.



NOTE Move the arm the brake is released by two persons or more (one presses the switch and one moves the arm). The arm can be very heavy and needs the significant force to move.

6.2 Camera Plate Unit

To mount a camera to the C4 series Manipulator, you need to mount the camera plate unit first.

Appearance of arm end with camera

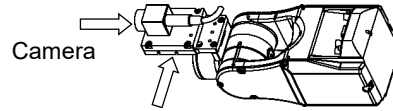

Camera plate unit

Parts included		unit
A	Camera adapter plate	1
B	Camera mid plate	1
C	Camera base plate	1
D	Hexagon socket head screws M4×12	6
E	hexagon socket head screws M4×20	2
F	Plain washer for M4 (small washer)	2

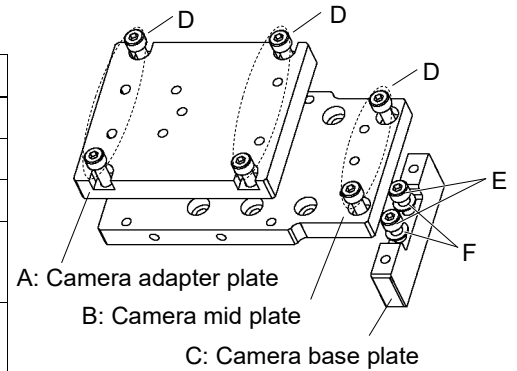

To mount the camera plate unit

- Mount the camera base plate to the Manipulator.
2-M4 × 20 + Plain washer for M4 (small washer)
- Mount the camera mid plate to the base plate.
2-M4 × 12

Mounting holes of
camera base plate

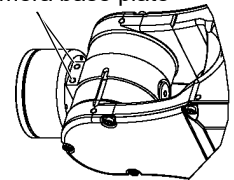

NOTE  The motion range and dimension of the Manipulator with the camera installed may vary depending on the mounting hole of camera mid plate. The details are described in the table below.

- Mount the camera to the camera adapter plate.

NOTE  According to the camera, the available mounting hole of adapter plate will be different. The details are described below.

- Mount the camera adapter plate and camera to the camera mid plate.
4-M4 × 12
- Secure the cables at the position where they do not interfere with the Manipulator motion.

NOTE  When securing the cables, check if the cables bend radius is big enough and the cables are not rubbing against each other while the Manipulator moves. Otherwise, the cables will be disconnected.

Dimension of the camera plate unit

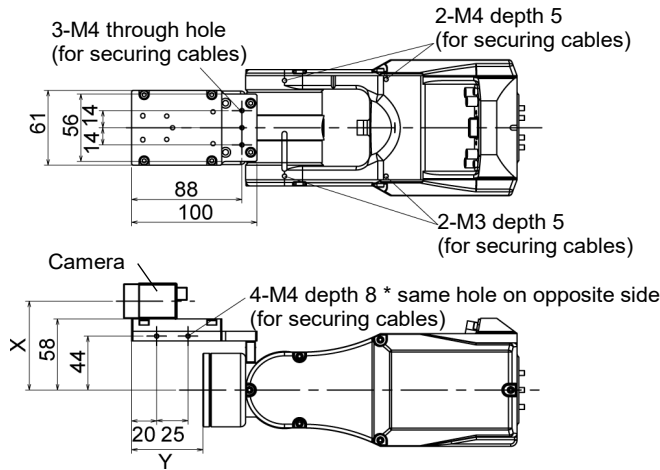

Dimensions X and Y will change depending on the position of camera mid plate and camera size. Refer to the table below for the values.

Camera mid plate

The camera mid plate uses the mounting holes A to D.

By using the different mounting holes, it can be mounted to the camera base plate in the different four positions.

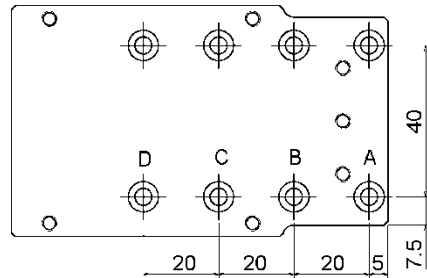

Camera adapter plate

Each camera uses the different mounting holes.

USB camera : J (2 holes)

GigE camera : E (3 holes)

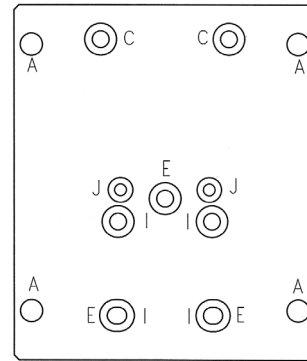

Mounting example

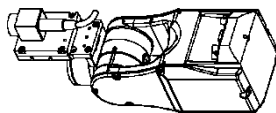

Using the mounting hole A

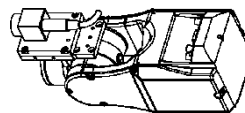

Using the mounting hole C

E.g.) Camera: XC-ES30

Camera and Joint #5 motion range (reference values)

The Joint #5 motion range varies depending on the mounting position of camera mid plate and the camera you are using.

The table below shows the motion range (reference values) based on the available cameras for this option and the mounting positions of the camera mid plate. The values in the table may vary depending on how to secure the cables.

By changing the Y position, you can extend the distance from the end effector mounting surface to the camera. Also, you can attach the larger end effector. However, be careful about the Joint #5 motion range that will be limited in this case.

(° = deg.)

	A	B	C	D	X
USB camera, GigE camera	-135° ~ +60°	-135° ~ +50°	-135° ~ +35°	-135° ~ +25°	72.5 mm

	A	B	C	D
Y	57 mm	37 mm	17 mm	7 mm

Direction of the Joint #5 motion

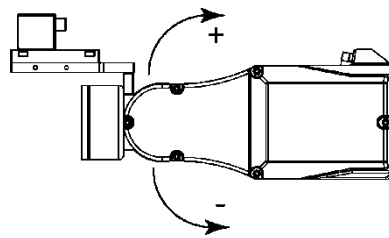

6.3 PS Compatible Plate (Tool Adapter)

Using the PS compatible plate, you can mount the end effector used in the PS series to the C4 series.

Parts included		Qty.
A	PS compatible plate 1	1
B	PS compatible plate 2	1
C	Hexagon socket head screw M4×6	4
D	Hexagon socket head screw M3×8	8
E	Dowel pin (M3 hole on one side)	2

Dimensions of PS compatible plate

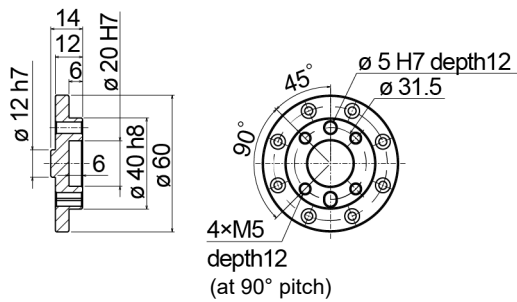

C: Hexagon socket head screw
4-M4×6

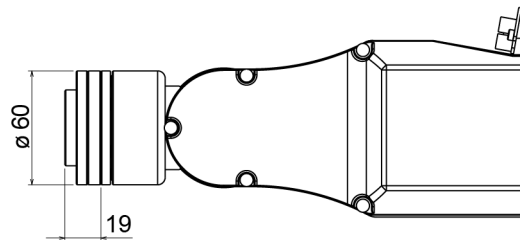
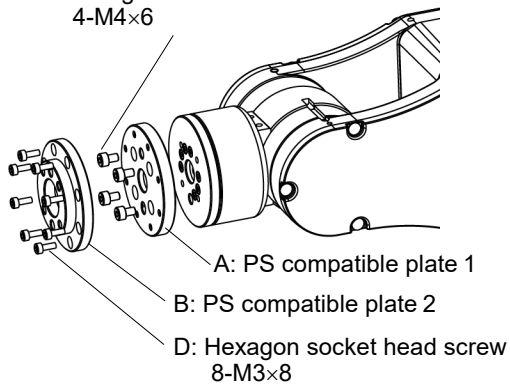

Installation

- (1) Align the hole on the arm end flange ($\phi 12H7$) to the projection on the PS compatible plate 1 ($\phi 12h7$).
- (2) Insert the dowel pin from the PS compatible plate 1 side and position the arm and PS compatible plate 1.
- (3) Secure the PS compatible plate 1 with 4 hexagon socket head screws.

4-M4×6

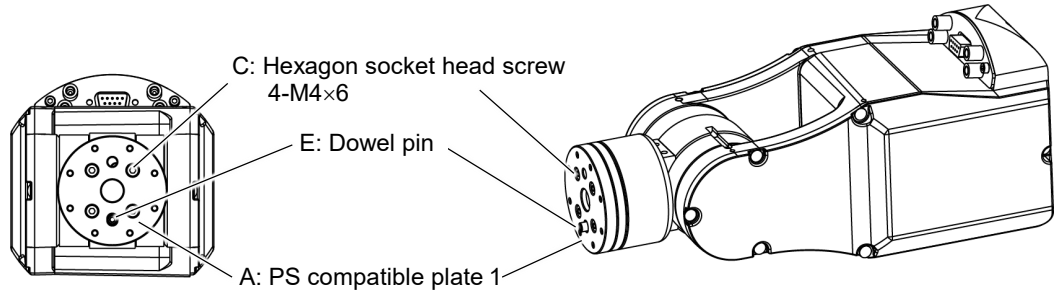

NOTE  If you move the Manipulator with the dowel pin inserted, the dowel pin will fall out. After fixing the PS compatible plate 1, remove the dowel pin.

- (4) Align the hole on the PS compatible plate 1 ($\phi 12H7$) to the projection on the PS compatible plate 2 ($\phi 12h7$).
- (5) Insert the dowel pin from the PS compatible plate 2 side and position the PS compatible plate 1 and 2.
- (6) Secure the PS compatible plate 2 with 8 hexagon socket head screws.

8-M3×8

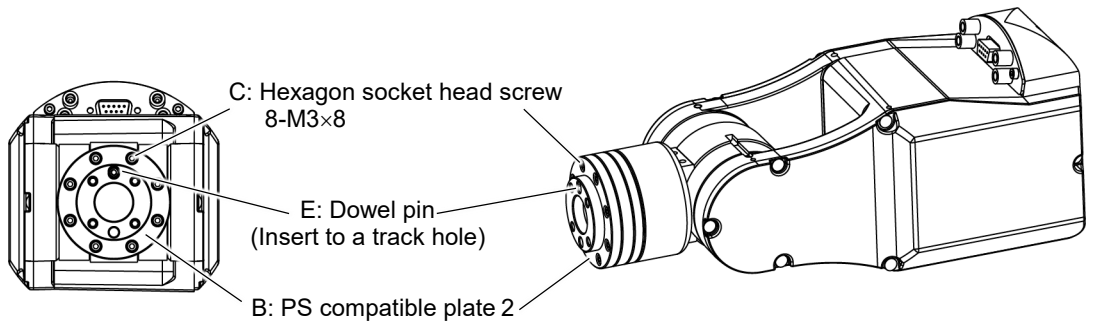

NOTE  If you move the Manipulator with the dowel pin inserted, the dowel pin will fall out. After fixing the PS compatible plate 2, remove the dowel pin.

6.4 Base Side Angled Fittings

By using the base side angled fittings to the C4 series Manipulator base, you can mount the Manipulator in skewed position. The motion range expands with this mounting type compared to the normal ceiling mounting.

Mounting image using the base side angled fittings

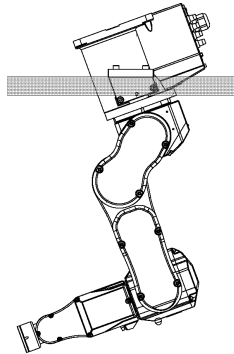

For details of the mounting and precautions, refer to *Setup & Operation: 3. Environment and Installation*.

Parts included		Qty.
A	Base side angled plate (Left side)	1
B	Base side angled plate (Right side)	1
C	Base side plate (for Skewed mounting type)	2
D	Pin	6
E	Hexagon socket head screw M8 × 25	4
F	Hexagon socket head screw M8 × 30	4

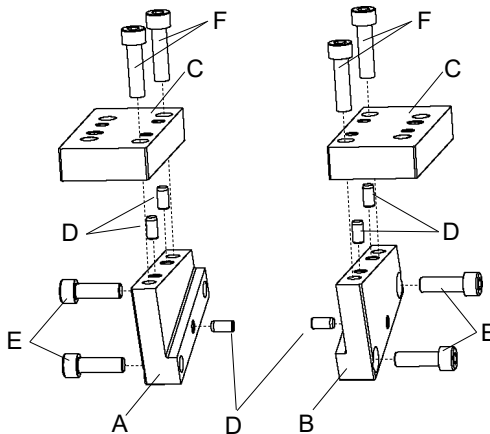

To mount the base side angled fittings

- (1) Drive pins to the base side plate (for Skewed mounting type).

Protruding part of pins is approx. 2 to 5 mm.

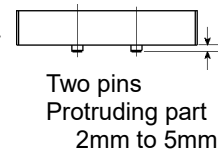

- (2) Drive pins to the base side angled plate (left & right sides).

Protruding part of pins is approx. 2 to 5 mm.

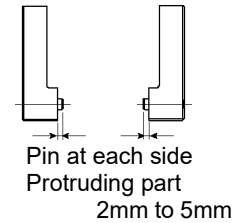

- (3) Create a base side angled fittings.

Fit the pins of the plate for Skewed mounting type in the step (1) with the holes on the plate in the step (2) and secure with the screws.

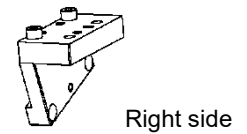

Hexagon socket head screw M8 × 30

- (4) Mount the base side angled fittings to the both sides of Manipulator base.

Fit the pins drove in the step (2) with the holes on the base. Secure the fittings by pressing it to the indicated direction in the figure below.

Left & Right side Hexagon socket heat screw 2- M8 × 25

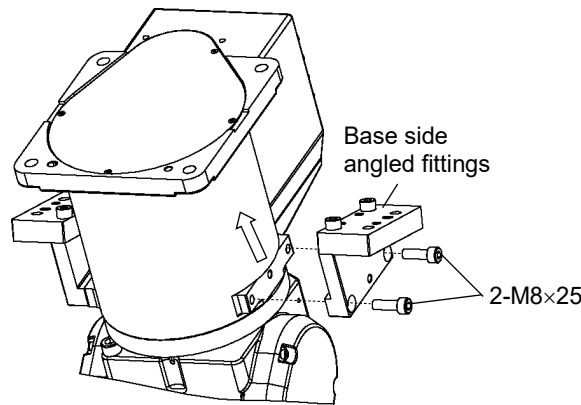

The shape of the base side angled fittings is asymmetry. Be sure to mount the fittings in correct direction. Otherwise, the motion range of Arm #2 is limited in the backside.



The recommended base plate thickness is between 30 mm and 40 mm. If the thickness is more than 40 mm, the Manipulator may contact the base plate when the Arm #1 rotates depending on the center cut dimension in the base plate.

The base plate securing the Manipulator should be prepared by users. The torque value and reaction force generated in the Manipulator motions are described in *Setup & Operation: 3.4 Installation*.

6.5 Base Side Fittings

Using the base side fittings to the C4 Manipulator base, you can mount the Manipulator in the place where limits the mounting height or use the open room for the base.

Mounting image using the base side fittings

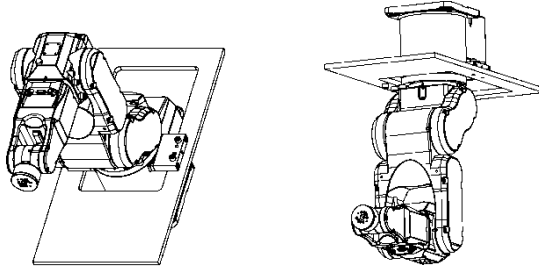

For the information on how to mount and precautions, refer to *Setup & Operation: 3. Environment and Installation.*

Parts included	Qty.
A Base side plate	2
B Pin	2
C Hexagon socket head screw M8 × 60	4

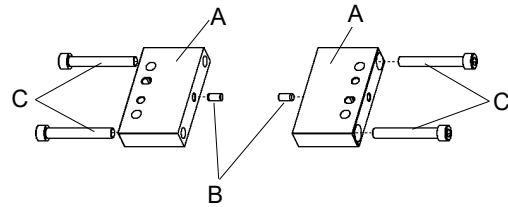

To mount the base side plate

- (1) Drive the pins to the base side plate.

Protruding part of pins is approx. 2 to 5 mm.

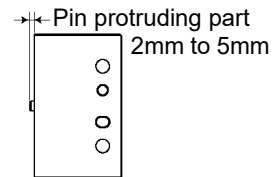

- (2) Mount the base side plate with the pins driven to the both sides of the base.

Fit the pins with the holes and secure the base side plate by pressing it from above to the base fixing part.

(With the steps above, the both surfaces of base side fittings can be stable.)

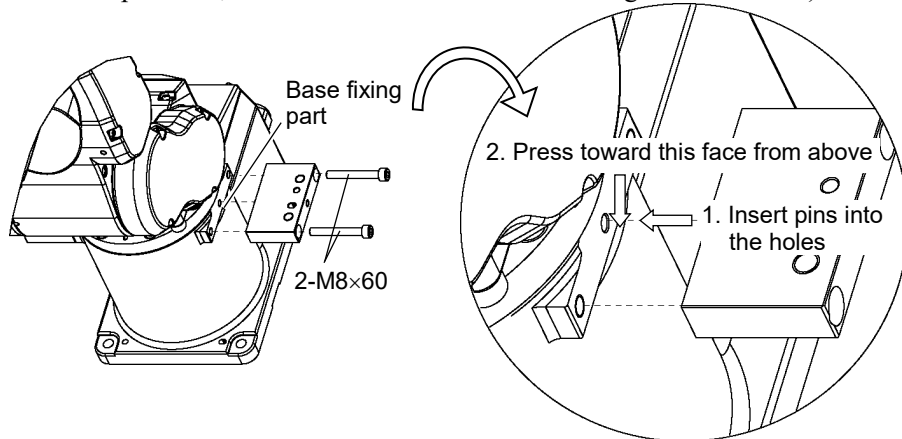

Dimension of the Manipulator with the base side fittings

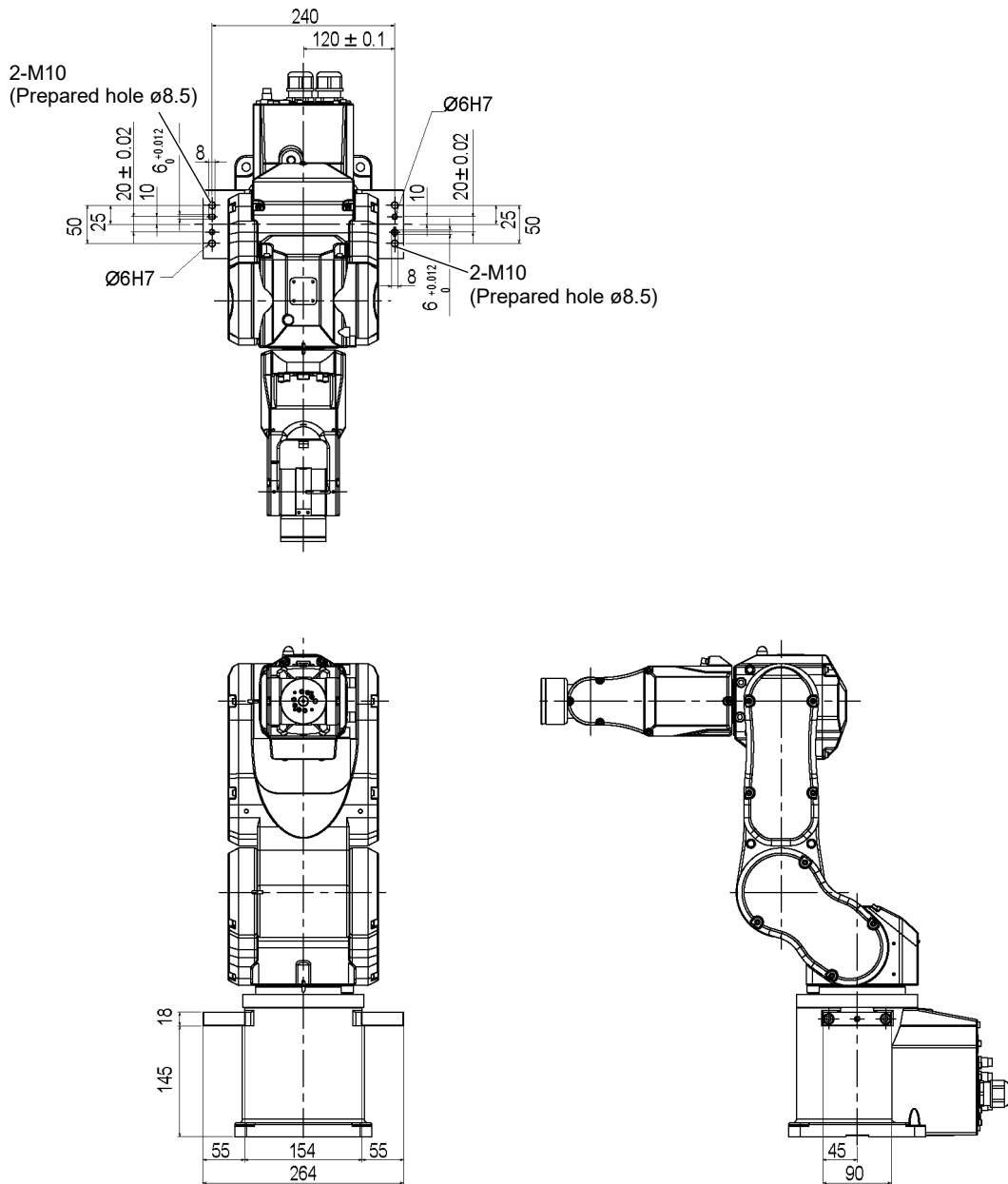

Installation example

Screws

	Size	Recommended length
A	M8	30 mm or more
B	M10	15 mm + Base Plate or more

NOTE  The base side plate has a M10 screw hole. You can secure the plate with a M10 screw or a M8 screw by using a prepared screw hole of $\varnothing 8.5$ to make a M8 screw hole on the mounting surface.

NOTE  A: Securing from above
 To secure from above, use the screw A in the table above.

When you install the Manipulator for practical use, you need to insert the screws in the right/left side from the same direction (above or below).

Table Top mounting

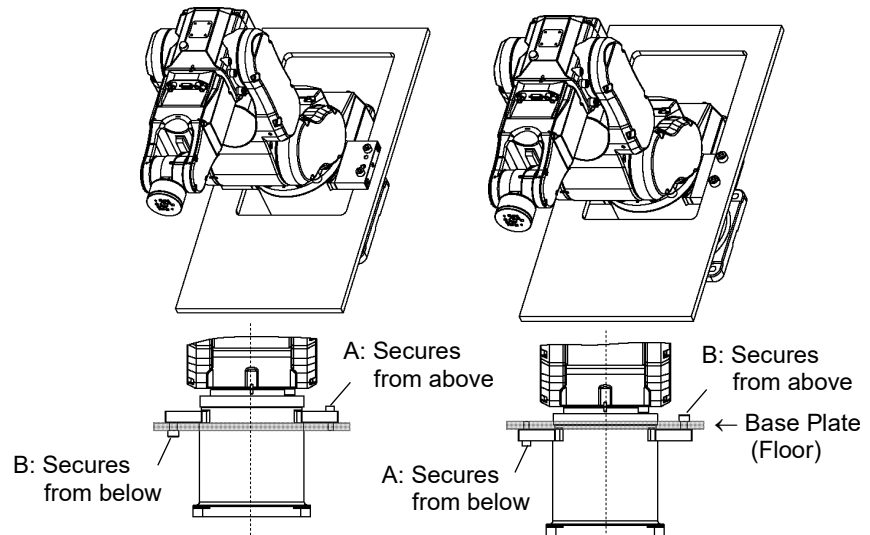

Ceiling mounting

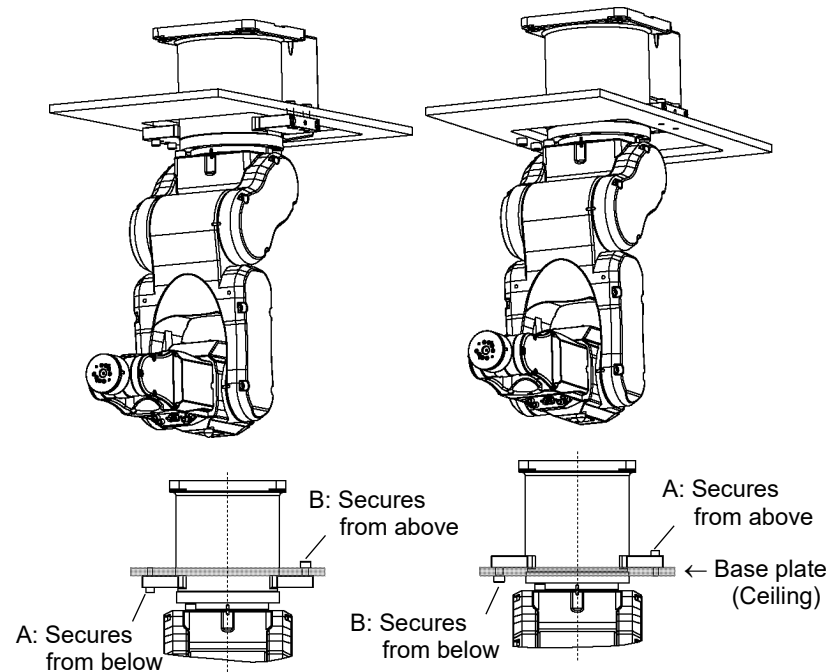

6.6 PS Compatible Plate (Base Adapter)

PS compatible plate is used to use Manipulator fixing taps for PS series to the C4 series Manipulator.

Parts included	Qty.
A PS compatible plate	1
B Dowel pin (M4 hole on one side)	3
C Dowel pin (M6 hole on one side)	2
D M10×25 hexagon socket head cap bolt	8
E Plain washer	4
F Spring washer	8

Dimensions of PS compatible plate

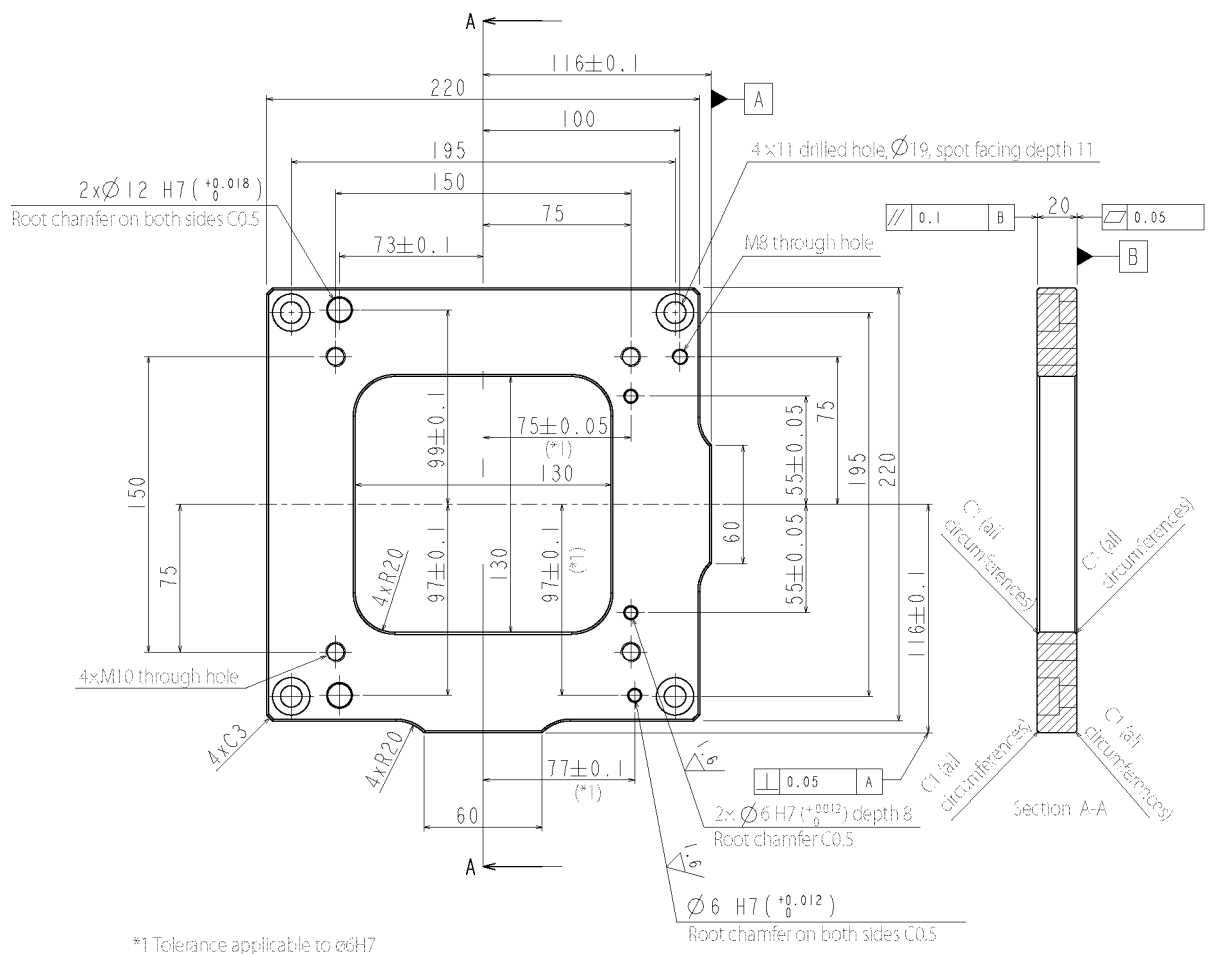

Installation

- Fix the mounting table and the PS compatible plate with hexagon socket head cap bolts and spring washers. Use dowel pins as needed to adjust positions of the mounting table and the PS compatible plate.
- Fix the C4 series Manipulator and the PS compatible plate.
 - Hexagon socket head cap bolts (4-M10×25) + spring washers + plain washers
 - Use dowel pins as needed to adjust positions of the Manipulator and the PS compatible plate.

6.7 Adjustable Mechanical Stop (Joint #2: only C4-A901**)

Adjustable mechanical stops physically limit the absolute area that the Manipulator can move.

Be sure to turn OFF the Controller in advance.

Use high corrosion-resistant stainless bolts or equivalent material.

Specify the pulse range again after changing the position of the mechanical stop.

For details on the pulse range setting, refer to the *Setup & Operation 5.1 Motion Range Setting by Pulse Range (for All Arms)*.

Be sure to set the pulse range not to exceed the setting angles of the mechanical stop.

	Parts included	Qty.
A	Adjustable mechanical stop	1
B	M6×40 hexagon socket head cap bolt	2
C	Plain washer	2

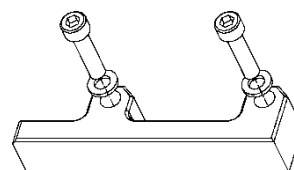

Installation

- (1) Remove the bolts fixing the Arm #2 spacer (2- M6×20).

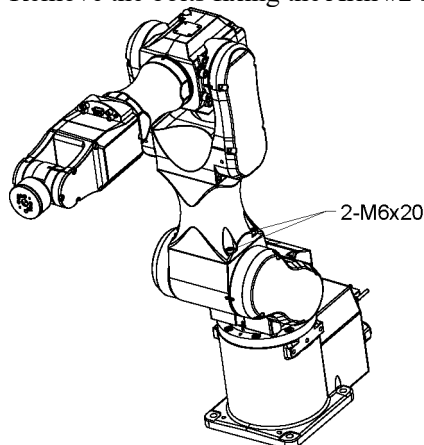

- (2) Fix the adjustable mechanical stop with the bolts (2-M6×40) and plain washers.
Direction of the adjustable mechanical stop depends on the angular limitation to be set.

Installation 1

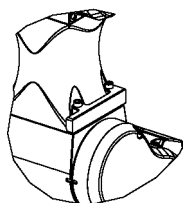

Installation 2

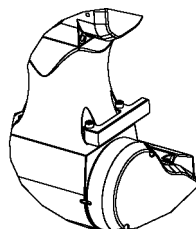

	Installation 1	Installation 2	-	-
Angle (°)	-153	+50	-160	+65
Pulse (pulse)	-4456448	+1456356	-7626008	+3098066
Adjustable mechanical stop	Applied	Applied	Not applied (standard)	Not applied (standard)

Maintenance

This volume contains maintenance procedures with safety precautions for C4 series Manipulators.

1. Safety Maintenance



Please read this chapter, this manual, and other relevant manuals carefully to understand safe maintenance procedures before performing any maintenance.

Only authorized personnel who have taken safety training should be allowed to perform the robot maintenance.

Safety training is the program for industrial robot operators to follow the laws and regulations of each nation.

The personnel who have taken safety training acquire knowledge of industrial robots (operations, teaching, etc.), inspections, and related rules/regulations.

The personnel who have completed the robot system-training and maintenance-training held by the manufacturer, dealer, or locally-incorporated company are allowed to perform maintenance.

 WARNING	<ul style="list-style-type: none"> ■ Do not remove any parts unless otherwise instructed by this manual. Follow the maintenance procedure strictly as described. Improper removal of parts or improper maintenance may cause not only malfunction of the robot system but serious safety problems. ■ If you have not received training, keep away from the Manipulator while the power is ON. Do not enter the operating area while the power is ON. Entering the operating area with the power ON is extremely hazardous and may cause serious safety problems as the Manipulator may move even it seems to be stopped. ■ When you check the operation of the Manipulator after replacing parts, be sure to check it while you are outside of the safeguarded area. Checking the operation of the Manipulator while you are inside of the safeguarded area may cause serious safety problems as the Manipulator may move unexpectedly. ■ Before operating the robot system, make sure that both the Emergency Stop switches and safeguard switch function properly. Operating the robot system when the switches do not function properly is extremely hazardous and may result in serious bodily injury and/or serious damage to the robot system as the switches cannot fulfill their intended functions in an emergency.
 WARNING	<ul style="list-style-type: none"> ■ To shut off power to the robot system, disconnect the power plug from the power source. Be sure to connect the AC power cable to a power receptacle. DO NOT connect it directly to a factory power source. ■ Before performing any replacement procedure, turn OFF the Controller and related equipment, and then disconnect the power plug from the power source. Performing any replacement procedure with the power ON is extremely hazardous and may result in electric shock and/or malfunction of the robot system. ■ When connecting / replacing the brake release unit or the external short connector, turn OFF the power to the Controller and the brake release unit. Inserting and removing the connector while the power is ON may result in electrical shock.



CAUTION

- Be sure to connect the cables properly. Do not allow unnecessary strain on the cables. (Do not put heavy objects on the cables. Do not bend or pull the cables forcibly.) It may result in damage to the cables, disconnection, and/or contact failure. These are extremely hazardous and may result in electric shock and/or improper function of the robot system.
- If the Manipulator is operated without connecting the brake release unit or the external short connector, the brakes cannot be released and it may cause damage on them. After using the brake release unit, be sure to connect the external short connector to the Manipulator, or check connection of the connector for the brake release unit.

2. General Maintenance

This chapter describes maintenance inspection procedures. Performing maintenance inspection properly is essential to prevent trouble and ensure safety.

Be sure to perform the maintenance inspections in accordance with the schedule.

2.1 Maintenance Inspection

2.1.1 Schedule for Maintenance Inspection

Inspection points are divided into five stages: daily, monthly, quarterly, biannual, and annual. The inspection points are added every stage.

If the Manipulator is operated for 250 hours or longer per month, the inspection points must be added every 250 hours, 750 hours, 1500 hours, and 3000 hours operation.

	Inspection Point					
	Daily inspection	Monthly inspection	Quarterly inspection	Biannual inspection	Annual inspection	Overhaul (replacement)
1 month (250 h)	Inspect every day	√				
2 months (500 h)		√				
3 months (750 h)		√	√			
4 months (1000 h)		√				
5 months (1250 h)		√				
6 months (1500 h)		√	√	√		
7 months (1750 h)		√				
8 months (2000 h)		√				
9 months (2250 h)		√	√			
10 months (2500 h)		√				
11 months (2750 h)		√				
12 months (3000 h)		√	√	√	√	
13 months (3250 h)		√				
⋮	⋮	⋮	⋮	⋮	⋮	⋮
20000 h						√

h = hour

2.1.2 Inspection Point

Inspection While the Power is OFF (Manipulator is not operating)

Inspection Point	Inspection Place	Daily	Monthly	Quarterly	Biannual	Annual
Check looseness or backlash of bolts/screws. Tighten them if necessary. (For the tightening torque, refer to <i>Maintenance: 2.4 Tightening Hexagon Socket Head Cap Bolts.</i>)	End effector mounting bolts	√	√	√	√	√
	Manipulator mounting bolts	√	√	√	√	√
	Each arm locking bolts	√	√	√	√	√
	Bolts/screws around shaft					√
	Bolts/screws securing motors, reduction gear units, etc.					√
Check looseness of connectors. If the connectors are loosen, push it securely or tighten.	External connectors on Manipulator (on the connector plates etc.)	√	√	√	√	√
	Manipulator cable unit		√	√	√	√
Visually check for external defects. Clean up if necessary.	External appearance of Manipulator	√	√	√	√	√
	External cables		√	√	√	√
Check for bends or improper location. Repair or place it properly if necessary.	Safeguard etc.	√	√	√	√	√
Check tension of timing belts. Tighten it if necessary.	Base Inside of Arms #1, 2, 3, 4				√	√
Grease conditions	Refer to <i>Maintenance: 2.3 Greasing.</i>					
Battery	Refer to <i>Maintenance: 12 Replacing the Battery Unit.</i>					
Check either the external short connector or the brake release unit connector is connected.	The external short connector on the back side of the Manipulator, or the brake release unit connector.	√	√	√	√	√

Inspection While the Power is ON (Manipulator is operating)

Inspection Point	Inspection Place	Daily	Monthly	Quarterly	Biannual	Annual
Check motion range	Each joint					√
Move the cables back and forth lightly to check whether the cables are disconnected.	External cables				√	√
Push each arm in MOTOR ON status to check whether backlash exists.	Each arm					√
Check whether unusual sound or vibration occurs.	Whole	√	√	√	√	√
Measure the accuracy repeatedly by a dial gauge.	Whole					√
<p>When brake release unit is installed: Connect the brake release unit and check the sound of the electromagnetic brake with the brake released. If there is no sound, replace the brake.</p> <p>When brake release unit is not installed: Execute Brake off command (brake off, joint #) from the command window of the EPSON RC+ while the motors are OFF, and then check the sound of the electromagnetic brake. If there is no sound, replace the brake.</p>	Brake	√	√	√	√	√

2.2 Overhaul (Parts Replacement)



CAUTION

- Overhaul timing is based on an assumption that all joints are operated for equal distance. If a particular joint has a high duty or high load, it is recommended to overhaul all joints (as many as possible) before exceeding 20,000 operation hours with the joint as a basis.

The parts for the Manipulator joints may cause accuracy decline or malfunction due to deterioration of the Manipulator resulting from long term use. In order to use the Manipulator for a long term, it is recommended to overhaul the parts (parts replacement).

The time between overhauls is 20,000 operation hours of the Manipulator as a rough indication.

However, it may vary depending on usage condition and degree of the load (such as when operated with the maximum motion speed and maximum acceleration/deceleration in continuous operation) applied on the Manipulator.

NOTE



For the EPSON RC+ 7.0 Ver. 7.2.x or later (firmware Ver.7.2.x.x or later), the recommended replacement time for the parts subject to maintenance (motors, reduction gear units, and timing belts) can be checked in the [Maintenance] dialog box of the EPSON RC+ 7.0.

For details, refer to the following manual.

Robot Controller RC700 / RC700-A Maintenance 6. Alarm

Note:

The recommended replacement time for the maintenance parts is when it reaches the L10 life (time until 10% failure probability). In the [Maintenance] dialog box, the L10 life is displayed as 100%.

The Manipulator operation hours can be checked in [Controller Status Viewer] dialog box-[Motor On Hours].

- (1) Select EPSON RC+ menu-[Tools]-[Controller] to open the [Controller Tools] dialog box.
- (2) Click the <View Controller Status> button to open the [Browse For Folder] dialog box.
- (3) Select the folder where the information is stored.
- (4) Click <OK> to view the [Controller Status Viewer] dialog box.
- (5) Select [Robot] from the tree menu on the left side.

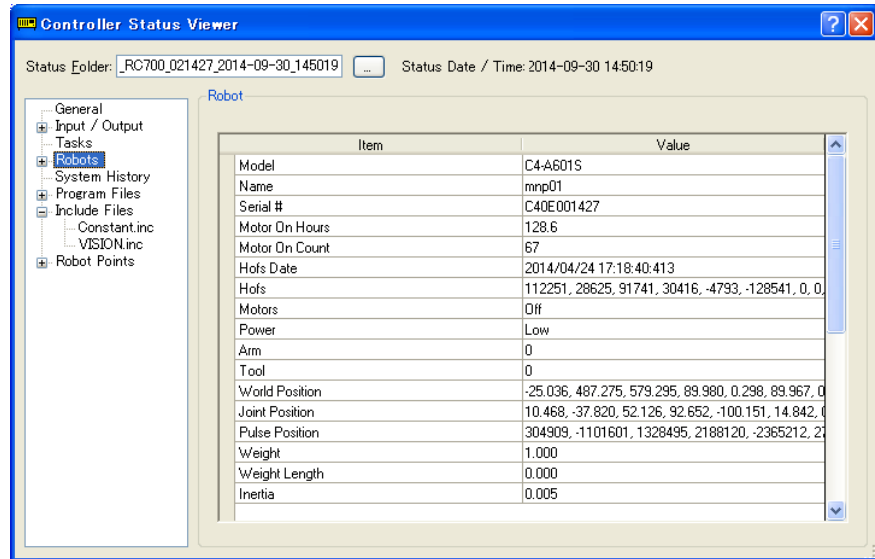

For the parts subject to overhaul, refer to *Maintenance 17. Maintenance Parts List*.

For details of replacement of each part, refer to the *Maintenance* section.

Please contact the supplier of your region for further information.

2.3 Greasing

The reduction gear units and the bevel gear need greasing regularly. Only use the grease specified in the following table.

 WARNING	<ul style="list-style-type: none"> Before performing any replacement procedure, turn OFF the Controller and related equipment, and then disconnect the power plug from the power source. Performing any replacement procedure with the power ON is extremely hazardous and may result in electric shock and/or malfunction of the robot system.
--	--

 CAUTION	<ul style="list-style-type: none"> Keep enough grease in the Manipulator. Operating the Manipulator with insufficient grease will cause the noise or damage sliding parts and/or result in insufficient function of the Manipulator. Once the parts are damaged, a lot of time and money will be required for the repairs. If grease gets into your eyes, mouth, or on your skin, follow the instructions below. <ul style="list-style-type: none"> If grease gets into your eyes: <ul style="list-style-type: none"> Flush them thoroughly with clean water, and then see a doctor immediately. If grease gets into your mouth: <ul style="list-style-type: none"> If swallowed, do not induce vomiting. See a doctor immediately. If grease just gets into your mouth, wash out your mouth with water thoroughly. If grease gets on your skin: <ul style="list-style-type: none"> Wash the area thoroughly with soap and water.
--	--

	Greasing part	Greasing Interval	Grease	Greasing method
Joint #1, 2, 3, 4	Reduction gear units	Overhaul timing	SK-1A	Refer to <i>Maintenance</i> : 5.2, 6.2, 7.2, 8.2 <i>Replacing the Reduction Gear Unit</i>
Joint #5, 6			SK-2	Refer to <i>Maintenance</i> : 9.2, 10.2 <i>Replacing the Reduction Gear Unit</i>
Joint # 6	Bevel gear	Once a year (every 8000 hours)	SK-2	Refer to the next page.

Joint #1, 2, 3, 4, 5, 6 reduction gear units

As a rough indication, perform greasing at the same timing as overhaul. However, it may vary depending on usage condition and degree of the load (such as when operated with the maximum motion speed and maximum acceleration / deceleration in continuous operation) applied on the Manipulator.

Greasing Joint #6 bevel gear

	Name	Quantity	Note
Maintenance Part	Grease (SK-2)	Proper quantity	-
Tools	Screw M4×15 (length: 15 mm or more)	1	For unplugging
	Wiping cloth	1	For wiping grease

- (1) Secure Arm #5 in the direction you can unplug the plug easily.
- (2) Insert the screw into the screw part (M4 depth 5) of the plug.
Screw : M4 length 15 mm or more (easy-to-unplug)
- (3) Hold the screw inserted in the step (2) and unplug the plug.
- (4) Apply the grease.
Grease: SK-2
Grease amount : 2 g
- (5) Insert the plug unplugged in the step (3) to the original position.
To prevent the grease leaking or unplugging, be sure to insert the plug all the way seated.
- (6) Pull out the screw inserted in the step (2).

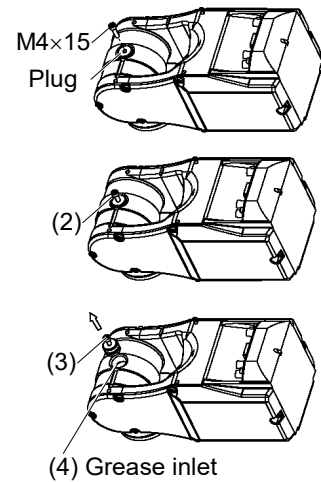

2.4 Tightening Hexagon Socket Head Bolts

Hexagon socket head cap bolts (hereinafter, “bolts”) are used in places where mechanical strength is required. These bolts are fastened with the tightening torque shown in the following tables.

When it is required to refasten the bolts in some procedures in this manual (except special cases as noted), use a torque wrench so that the bolts are fastened with appropriate tightening torque as shown below.

Bolt	Tightening Torque
M3	2.0 ± 0.1 N·m (21 ± 1 kgf·cm)
M4	4.0 ± 0.2 N·m (41 ± 2 kgf·cm)
M5	8.0 ± 0.4 N·m (82 ± 4 kgf·cm)
M6	13.0 ± 0.6 N·m (133 ± 6 kgf·cm)
M8	32.0 ± 1.6 N·m (326 ± 16 kgf·cm)
M10	58.0 ± 2.9 N·m (590 ± 30 kgf·cm)
M12	100.0 ± 5.0 N·m (1,020 ± 51 kgf·cm)

See below for the set screw.

Set Screw	Tightening Torque
M4	2.4 ± 0.1 N·m (26 ± 1 kgf·cm)
M5	3.9 ± 0.2 N·m (40 ± 2 kgf·cm)

It is recommended to fasten the bolts aligned on a circumference in a crisscross pattern as shown in the figure below.

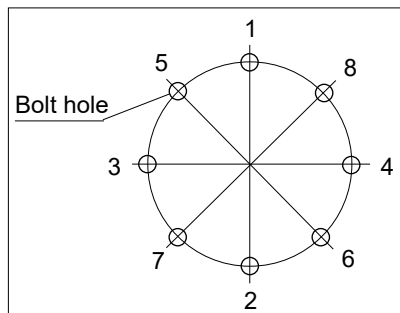

Do not fasten all bolts securely at one time. Divide the number of times to fasten the bolts into two or three and fasten the bolts securely with a hexagonal wrench. Then, use a torque wrench to fasten the bolts with tightening torques shown in the table above.

2.5 Layout of Maintenance Parts

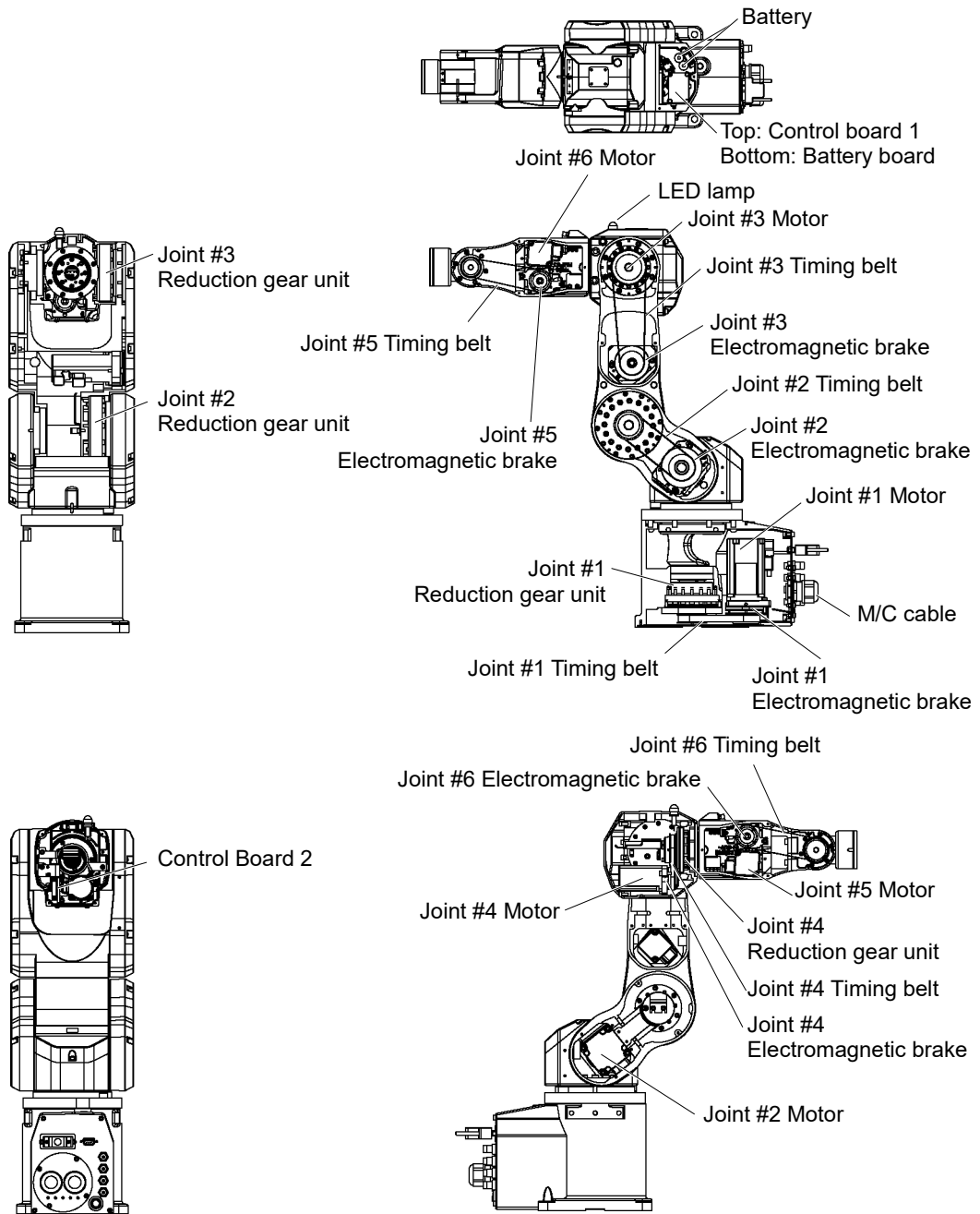

3. Covers

This chapter describes procedures for removing and installing covers and arm spacers in maintenance.



WARNING

- Do not connect or disconnect the motor connectors while the power to the robot system is turned ON. Connecting or disconnecting the motor connectors with the power ON is extremely hazardous and may result in serious bodily injury as the Manipulator may move abnormally, and also may result in electric shock and/or malfunction of the robot system.
- To shut off power to the robot system, disconnect the power plug from the power source. Be sure to connect the AC power cable to a power receptacle. DO NOT connect it directly to a factory power source.
- Before performing any replacement procedure, turn OFF the Controller and related equipment, and then disconnect the power plug from the power source. Performing any replacement procedure with the power ON is extremely hazardous and may result in electric shock and/or malfunction of the robot system.
- Be careful not to get any foreign substances in the Manipulator, connectors, and pins during maintenance. Turning ON the power to the robot system when any foreign substances exist in them is extremely hazardous and may result in electric shock and/or malfunction of the robot system.

	Name	Quantity	Note
Tools	Hexagonal wrench (width across flats: 2.5 mm)	1	For M3 hexagon socket head cap bolts
	Hexagonal wrench (width across flats: 3 mm)	1	For M4 hexagon socket head cap bolts
	Cross-point screwdriver	1	For covers

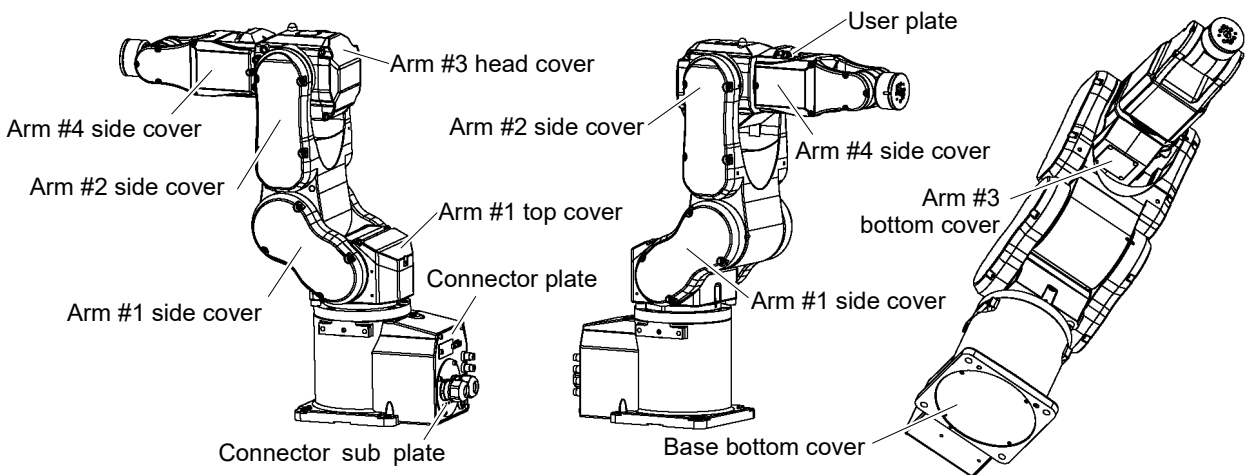

3.1 Arm #1 Top Cover



CAUTION

- When mounting the cover, be careful not to get the cables caught in it or bend them forcibly to push into the cover. Unnecessary strain on cables may result in damage to the cables, disconnection, and/or contact failure. These are extremely hazardous and may result in electric shock and/or improper function of the robot system. When routing the cables, check the cable locations at removing the cover. Be sure to place the cables back to their original locations.

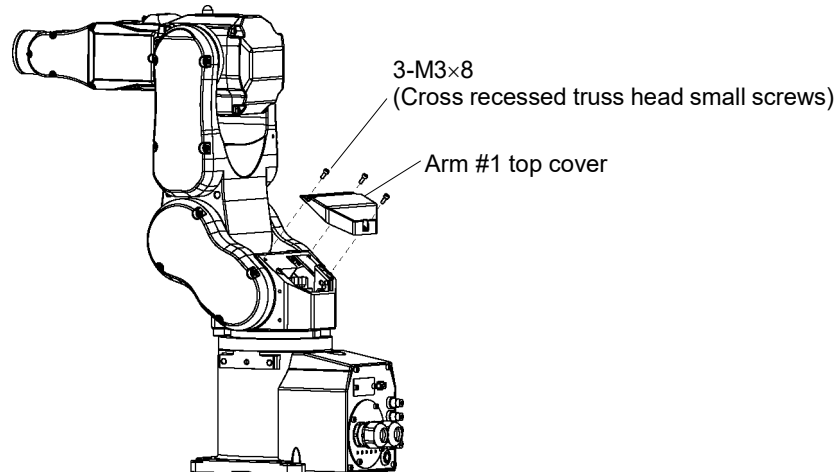

3.2 Arm #1 Side Cover



CAUTION

- When mounting the cover, be careful not to get the cables caught in it or bend them forcibly to push into the cover. Unnecessary strain on cables may result in damage to the cables, disconnection, and/or contact failure. These are extremely hazardous and may result in electric shock and/or improper function of the robot system. When routing the cables, check the cable locations at removing the cover. Be sure to place the cables back to their original locations.

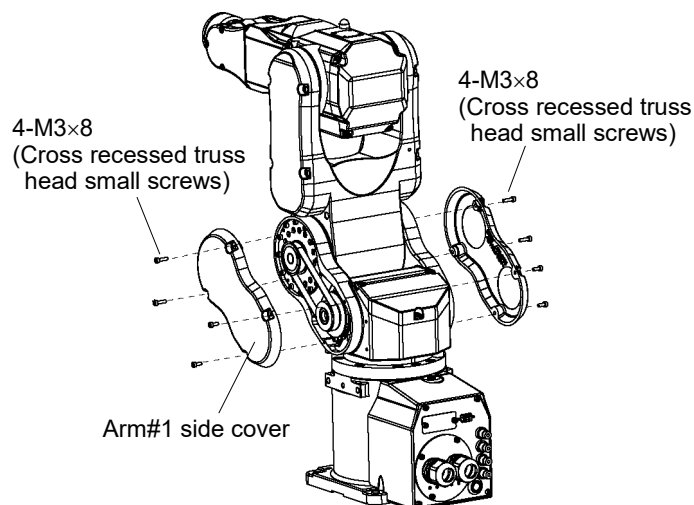

3.3 Arm #2 Side Cover



- When mounting the cover, be careful not to get the cables caught in it or bend them forcibly to push into the cover. Unnecessary strain on cables may result in damage to the cables, disconnection, and/or contact failure. These are extremely hazardous and may result in electric shock and/or improper function of the robot system. When routing the cables, check the cable locations at removing the cover. Be sure to place the cables back to their original locations.

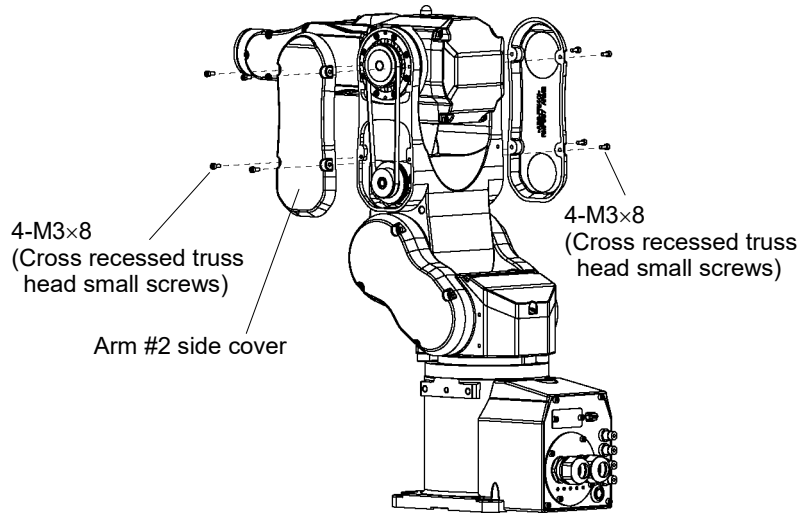

3.4 Arm #3 Head Cover



- When mounting the cover, be careful not to get the cables caught in it or bend them forcibly to push into the cover. Unnecessary strain on cables may result in damage to the cables, disconnection, and/or contact failure. These are extremely hazardous and may result in electric shock and/or improper function of the robot system. When routing the cables, check the cable locations at removing the cover. Be sure to place the cables back to their original locations.

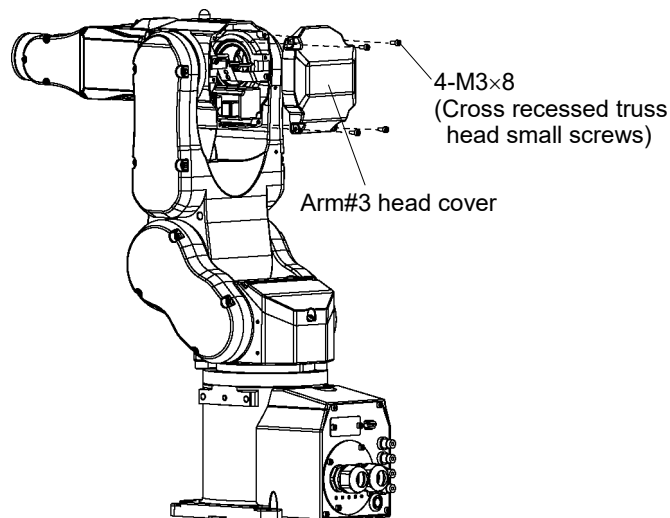

3.5 Arm #3 Bottom Cover



CAUTION

- When mounting the cover, be careful not to get the cables caught in it or bend them forcibly to push into the cover. Unnecessary strain on cables may result in damage to the cables, disconnection, and/or contact failure. These are extremely hazardous and may result in electric shock and/or improper function of the robot system. When routing the cables, check the cable locations at removing the cover. Be sure to place the cables back to their original locations.

Before removing the Arm #3 bottom cover, move the arm to the position where you can remove the cover easily.

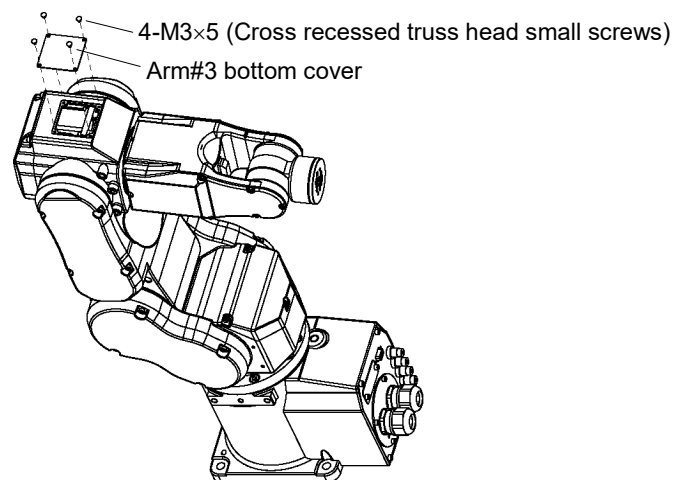

3.6 Arm #4 side cover



CAUTION

- When mounting the cover, be careful not to get the cables caught in it or bend them forcibly to push into the cover. Unnecessary strain on cables may result in damage to the cables, disconnection, and/or contact failure. These are extremely hazardous and may result in electric shock and/or improper function of the robot system. When routing the cables, check the cable locations at removing the cover. Be sure to place the cables back to their original locations.

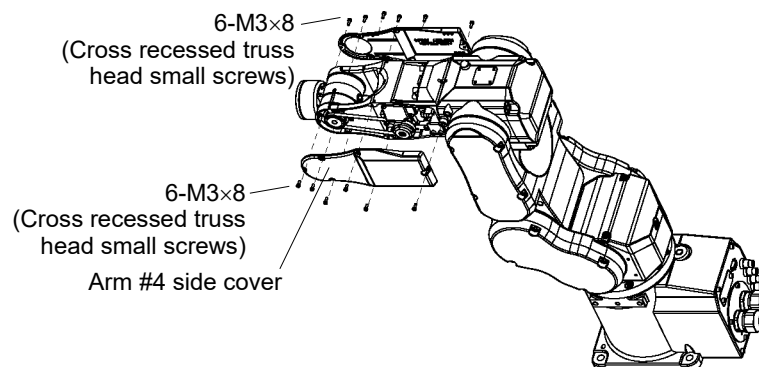

3.7 Base Bottom Cover

 CAUTION	<ul style="list-style-type: none"> When mounting the cover, be careful not to get the cables caught in it or bend them forcibly to push into the cover. Unnecessary strain on cables may result in damage to the cables, disconnection, and/or contact failure. These are extremely hazardous and may result in electric shock and/or improper function of the robot system. When routing the cables, check the cable locations at removing the cover. Be sure to place the cables back to their original locations.
--	---

Remove the screws (cross-recessed flat head machine screws) securing the cover and remove the cover.
 If you use the other screws than the screws indicated here, the screw head will protrude from the base surface and it will make it difficult to mount the Manipulator firmly. We recommend using our attached screws or equivalent ones.

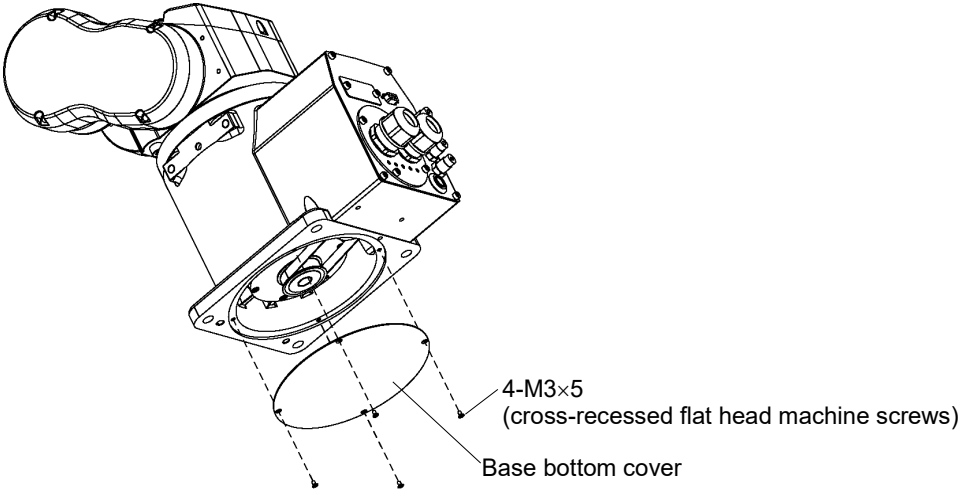

3.8 Connector Plate

 CAUTION	<ul style="list-style-type: none"> Do not remove the connector plate forcibly. Removing the connector plate forcibly may result in damage to the cables, disconnection, and/or contact failure. Damaged cables, disconnection, or contact failure is extremely hazardous and may result in electric shock and/or improper function of the robot system. When installing the connector plate, be careful not to get the cables caught in it or bend them forcibly to push into the cover. Unnecessary strain on cables may result in damage to the cables, disconnection, and/or contact failure. These are extremely hazardous and may result in electric shock and/or improper function of the robot system. When routing the cables, check the cable locations at removing the connector plate. Be sure to place the cables back to their original locations.
--	---

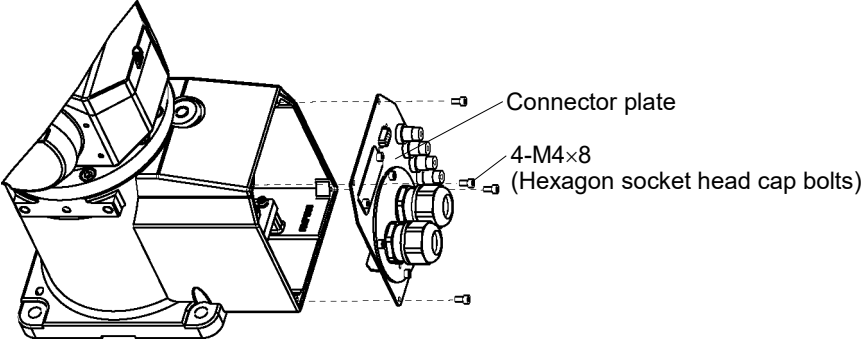

3.9 Connector Sub Plate



- Do not remove the connector sub plate forcibly. It may result in damage to the cables, disconnection, and/or contact failure. These are extremely hazardous and may result in electric shock and/or improper function of the robot system.
- When installing the connector sub plate, be careful not to get the cables caught in it or bend them forcibly to push into the cover. Unnecessary strain on cables may result in damage to the cables, disconnection, and/or contact failure. These are extremely hazardous and may result in electric shock and/or improper function of the robot system. When routing the cables, check the cable locations at removing the connector sub plate. Be sure to place the cables back to their original locations.

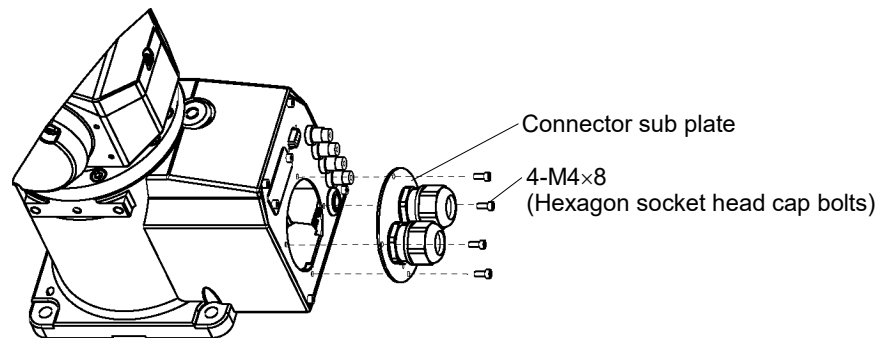

3.10 User Plate



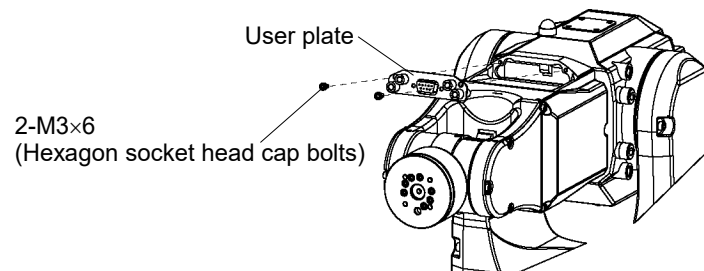

- Do not remove the connector plate forcibly. It may result in damage to the cables, disconnection, and/or contact failure. These are extremely hazardous and may result in electric shock and/or improper function of the robot system.
- When installing the user plate, be careful not to get the cables caught in it or bend them forcibly to push into the cover. Unnecessary strain on cables may result in damage to the cables, disconnection, and/or contact failure. These are extremely hazardous and may result in electric shock and/or improper function of the robot system. When routing the cables, check the cable locations at removing the user plate. Be sure to place the cables back to their original locations.



4. Cable Unit

4.1 Replacing the Cable Unit

 WARNING	<ul style="list-style-type: none"> ■ Before performing any replacement procedure, turn OFF the Controller and related equipment, and then disconnect the power plug from the power source. Performing any replacement procedure with the power ON is extremely hazardous and may result in electric shock and/or malfunction of the robot system. ■ Do not connect or disconnect the motor connectors while the power to the robot system is turned ON. Connecting or disconnecting the motor connectors with the power ON is extremely hazardous and may result in serious bodily injury as the Manipulator may move abnormally, and also may result in electric shock and/or malfunction of the robot system. ■ Be sure to connect the AC power cable to a power receptacle. DO NOT connect it directly to a factory power source. To shut off power to the robot system, disconnect the power plug from the power source. Performing any work while connecting the AC power cable to a factory power source is extremely hazardous and may result in electric shock and/or malfunction of the robot system. ■ Be careful not to get any foreign substances in the Manipulator, connectors, and pins during maintenance. Turning ON the power to the robot system when any foreign substances exist in them is extremely hazardous and may result in electric shock and/or malfunction of the robot system. ■ Be sure to connect the cables properly. Do not allow unnecessary strain on the cables. (Do not put heavy objects on the cables. Do not bend or pull the cables forcibly.) Unnecessary strain on the cables may result in damage to the cables, disconnection, and/or contact failure. These are extremely hazardous and may result in electric shock and/or improper function of the robot system. ■ When installing the cover, be careful not to allow the cables to interfere with the cover mounting and do not bend these cables forcibly to push them into the cover. Unnecessary strain on cables may result in damage to the cables, disconnection, and/or contact failure. Damaged cables, disconnection, or contact failure is extremely hazardous and may result in electric shock and/or improper function of the robot system. When routing the cables, observe the cable locations after removing the cover. Be sure to place the cables back to their original locations.
--	--

 CAUTION	<ul style="list-style-type: none"> ■ When disconnecting the connectors during the replacement of the cable unit, be sure to reconnect the connectors to their proper positions. Improper connection of the connectors may result in improper function of the robot system. For details on the connections, refer to the <i>Maintenance 4.2 Connector Pin Assignments</i>.
--	---



CAUTION

- Carefully use alcohol and adhesive following respective instructions and also instructions below. Otherwise, it may cause a fire and/or safety problems.
 - Never put alcohol or adhesive close to fire.
 - Use alcohol or adhesive while ventilating the room.
 - Wear protective gear including a mask, protective goggles, and oil-resistant gloves.
 - If alcohol or adhesive gets on your skin, wash the area thoroughly with soap and water.
 - If alcohol or adhesive gets into your eyes or mouth, flush your eyes or wash out your mouth with clean water thoroughly, and then see a doctor immediately.
- Wear protective gear including a mask, protective goggles, and oil-resistant gloves during grease up. If grease gets into your eyes, mouth, or on your skin, follow the instructions below.
 - If grease gets into your eyes : Flush them thoroughly with clean water, and then see a doctor immediately.
 - If grease gets into your mouth : If swallowed, do not induce vomiting. See a doctor immediately.
If grease just gets into your mouth, wash out your mouth with water thoroughly.
 - If grease gets on your skin : Wash the area thoroughly with soap and water.

	Name		Quantity	Note
Maintenance Parts	Cable unit	for C4-A601**	1	2149411
		for C4-A901**	1	2155583
		for C4-A601**-UL	1	2182507
		for C4-A901**-UL	1	2182508
	Battery relay cable unit		1	1653173 (Reusable See "Note" below)
Tools	Hexagonal wrench (width across flats: 2.5 mm)		1	For M3 hexagon socket head cap bolt
	Hexagonal wrench (width across flats: 3 mm)		1	For M4 hexagon socket head cap bolt
	Box wrench (width across flats: 5 mm)		1	For D-Sub connector
	Long nose pliers		1	For removing air connector
	Nippers		1	
	Cross-point screwdriver		1	
	Brush		1	For applying grease
	Force gauge		1	For belt tension
	Torque rench		1	
Material	Alcohol		Proper quantity	
	Wire tie	AB100	9	
		AB150	11	
		AB250	2	

Note: The battery relay cable unit is reusable. If the cable or the connector clip is broken during replacement of the cable unit and battery, replace the cable unit. For details on the replacement, refer to Removal step (10) and Installation step (55) in *Maintenance 4. Cable Unit*.

Removal: Cable unit

1. Move the Manipulator to the origin (0 pulse position).
2. Turn OFF the Controller power.
3. Remove the following covers and plates.

For details, refer to *Maintenance: 3. Covers*.

- | | |
|--------------------------------|--------------------------------|
| Arm #4 side cover (Both sides) | User plate |
| Arm #3 head cover | Arm #3 bottom cover |
| Arm #2 side cover (Both sides) | Arm #1 side cover (Both sides) |
| Arm #1 top cover | Connector plate |

When removing the user plate and the connector plate, remove the following parts together.

- D-sub 9-pin connector
- D-sub 15-pin connector
- Air tube × 4

4. Disconnect the connectors inside the base.

Connectors:

- X010, X020, X030, X040, X050, X060,
- LED, BR010, BR011, BR020, BR030,
- BR040, BR050, BR060, BT1,
- X11, X12, X13, X14, X15, X16, XGND,
- GS01,GS02

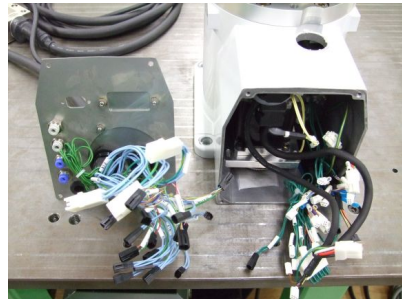
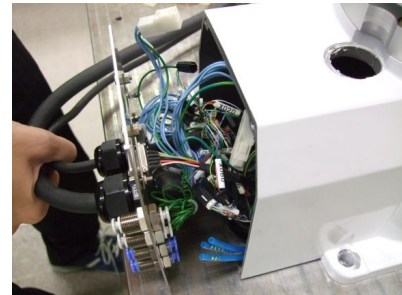

5. Remove the connector connected to the control board 1.

Connector: GS01



6. Remove the control board 1 inside the Arm #1.

Cross recessed head screws: 3-M3×8



7. Cross recessed head screws: 3-M3×8

Connectors: 2 connectors for the batteries, BT-CN1, BT-CN2

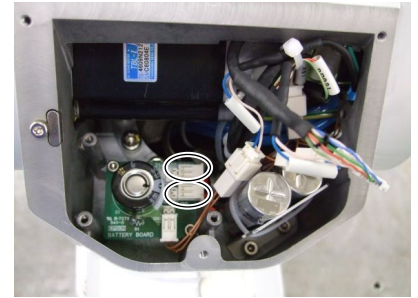

8. Remove the battery board.

Hexagon socket head cap bolts: 2-M3×8



9. Remove the battery unit.

Hexagon socket head cap bolts: 2-M4×8

The battery unit and battery relay cable will be used again.
Be careful not to lose them.

If you are replacing the battery relay cable, follow the step (10).



10. If replacing the battery relay cable:

Remove the connectors connected to the battery.

Connectors: 2 connectors for the batteries, BT

The battery unit will be used again.
Be careful not to lose it.

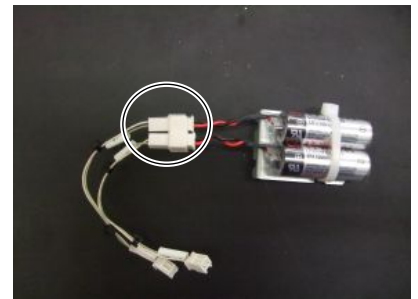

11. Cut off the wire ties binding the cables inside the Arm #3.

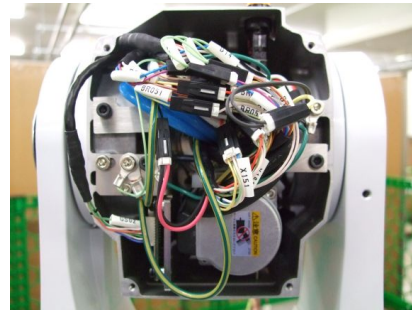
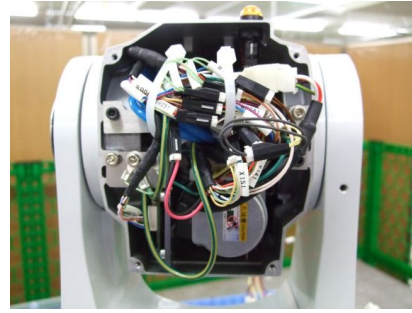

12. Remove the connectors inside the Arm #3.

Connectors:

- X71, X72*, X041, X051, X061*,
- LED, BR041, BR051, BR061*,
- BT4, BT51, BT61*, X141, X151, X161*, XGND,
- GS02

*: X72, X061, BR061, BT61, and X161 may not be existed.

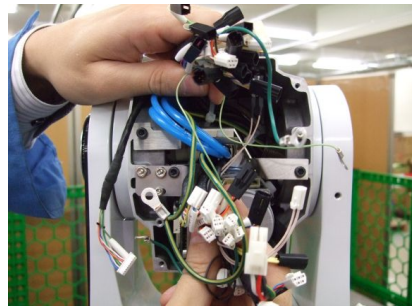

13. Remove the Arm #4 cable fixing plate (with the ground wires) from the Arm #4.

Hexagon socket head cap bolts: 2-M4×8

The Arm #4 cable fixing plate will be used again.
Be careful not to lose it.

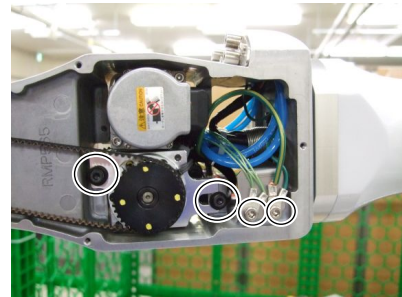

14. Remove the connectors inside the Arm #4.

Connectors:

- X052, X152, BT52, BR052,
- X062, X162, BT62, BR062

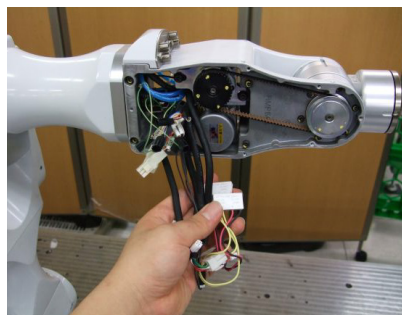

15. Remove the Joint #5 motor unit and the Joint #5 belt from the Arm #4.

Hexagon socket head cap bolts: 2-M4×15 (with a plain washer)

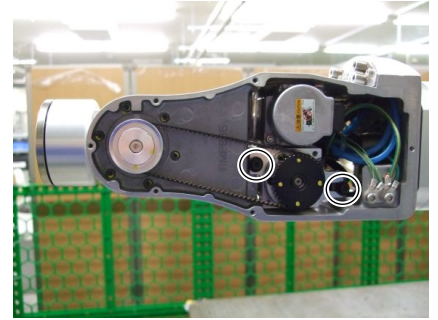

16. Remove the Joint #6 motor unit and the Joint #6 belt from the Arm #4.

Hexagon socket head cap bolts: 2-M4×15 (with a plain washer)

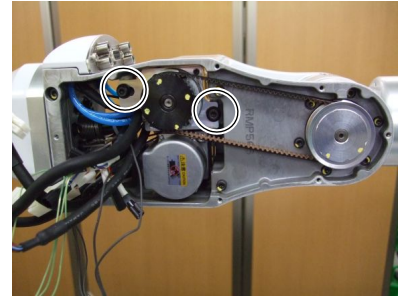

17. Cut off the following bands from the Arm #4 cable fixing plate.

Cable band

Coil plate fixing band

18. Remove the following parts from the Arm #3.

Arm #3 cable fixing plate (circle)

Hexagon socket head cap bolts: 2-M4×8

Ground wire fixing bolts (triangle)

Hexagon socket head cap bolts: 2-M4×8

Control board 2 (square)

Hexagon socket head cap bolt: 1-M4×10

Hexagon socket head cap bolt: 1-M3×8

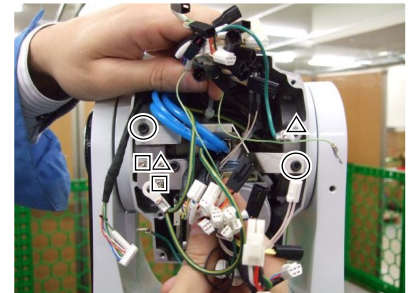

19. Cut off wire ties of the Arm #3 cable fixing plate.

Cable band

Coil plate fixing band

20. Pull out four air tubes and a ground wire from the Arm #3.
(See an arrow in the photo for pulling direction.)

The Arm #3 cable fixing plate will be used again.
Be careful not to lose it.

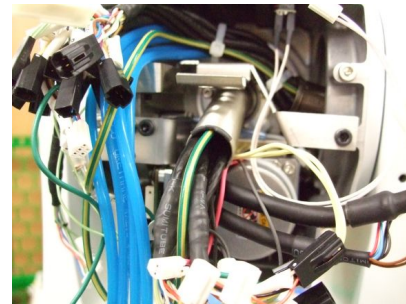
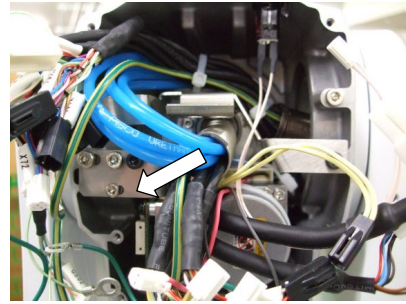

21. Pull out the following cables and a small diameter spring from the Arm #4. (See an arrow in the photo for pulling direction.)

Joint #5 motor cable and brake cable
Joint #6 motor cable, brake cable
Cable for installed wire for customer use

Connector:

X051, X061*, X151, X161*, XGND,
BR051, BR061*, BT51, BT61*

*: X061, X161, BR061, and BT61 may not be existed.

When pulling out the cables, carefully treat cables and connectors to prevent damage to them.

Pull out the cables in the order of connector size, from smallest to largest.

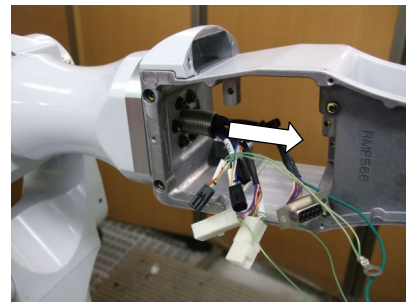

22. Pull out the Arm #3 cable unit from the Arm #2.
(See an arrow in the photo for pulling direction.)

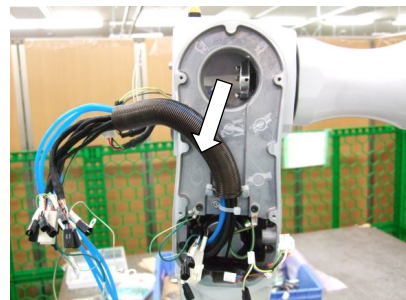

23. Disconnect the connectors of the Joint #3 motor and remove the Joint #3 motor.

Connectors: X031, X131, BT3, BR031, D

Hexagon socket head cap bolts: 2-M4×15 (with a plain washer)

Arm #3, #4, #5 and #6 lean when the motor is removed. Remove the motor after pushing the Arm to the stopper.

Connector D will be used again. Be careful not to lose it.

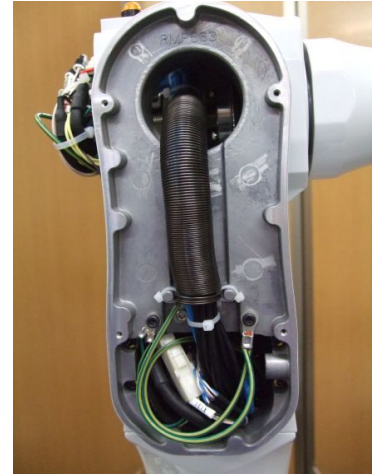

24. Cut off the wire tie of the Arm #2.

25. Remove two ground wires.

Hexagon socket head cap bolts: 2-M4×8

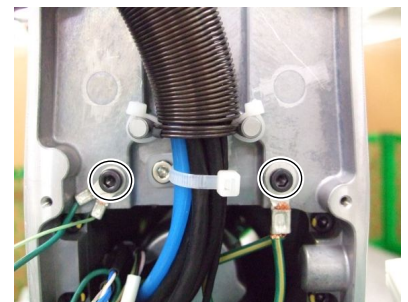

26. Remove the Arm #2 cable fixing plate.

Hexagon socket head cap bolts: 2-M4×8

It is not necessary to remove the fixing bolts completely.

Remaining the bolts on the Arm #2 makes it easy to mount the cable unit.

Pull out the cables from the Arm #1.



27. Cut off the binding tie of the Arm #1.

28. Remove two ground wires.

Hexagon socket head cap bolts: 2-M4×8



29. Disconnect the connectors of the Joint #2 motor and remove the Joint #2 motor.

Connectors: X021, X121, BT2, BR021, D

Hexagon socket head cap bolts: 3-M4×15 (with a plain washer)

Arm #3, #4, #5, and #6 lean when the motor is removed.

Remove the motor after pushing the Arm to the stopper.

Connector D will be used again. Do not lose it.

30. Remove the Arm #1 cable fixing plate.

Hexagon socket head cap bolt: M4×8, M6×20

31. Cut off the wire tie of the Arm #1 cable fixing plate.
The Arm #1 cable fixing plate will be used again.
Be careful not to lose it.

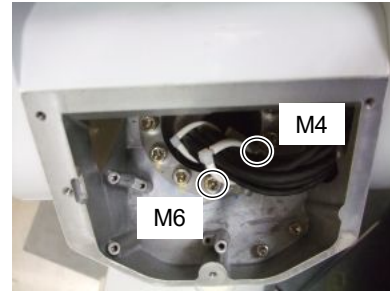

32. Be careful not to lose it.

Base cable fixing plate

Hexagon socket head cap bolt: 2-M4×8

Ground wire

Hexagon socket head cap bolt: 4-M4×8

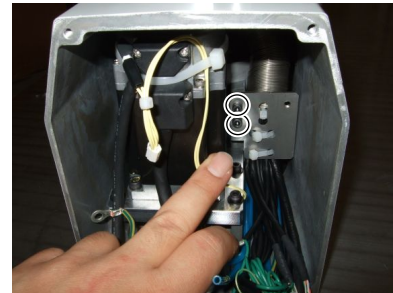

33. Cut off the wire tie of the base cable fixing plate.

The base cable fixing plate will be used again.
Be careful not to lose it.



34. Pull out the cables in the Arm #2 and the base from the Arm #1.
(See an arrow in the photo for pulling direction.)

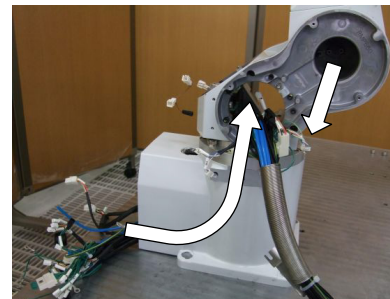

35. Remove the Arm #2 cable fixing plate from the cables.

The Arm #2 cable fixing plate will be used again.
Be careful not to lose it.

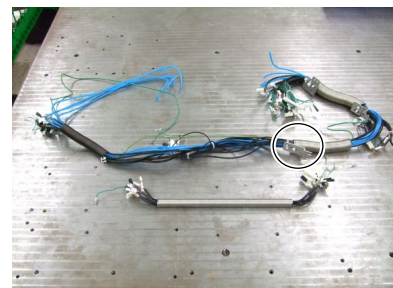

Installation: Cable unit

1. Check if the cable unit contains the following parts.

Silicone sheet: 30 mm × 150 mm

Silicone sheet: 15 mm × 50 mm

Mark tube

Wire tie: AB100, AB150, AB200

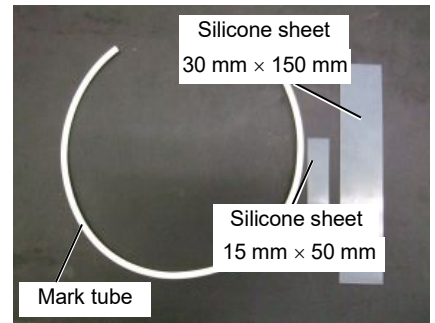

2. Separate the cable unit.

Connectors:

X051, X061, X151, X161, XGND, BR051, BR061,
BT51, BT61, X71, X72, SW1

This operation is not necessary if the cable unit is separated from the beginning.

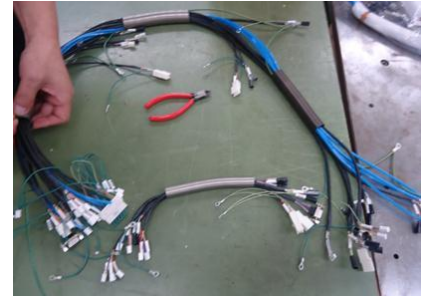

3. Cut the mark tube into following length.

68 mm × 2 (for fixing the J1 wire tie)

65 mm (for fixing the J2 wire tie) 23 mm × 2 (for fixing the J2 wire tie)

21 mm × 2 (for fixing the J3 wire tie) 57 mm × 2 (for fixing the J3 wire tie)

46 mm (for fixing the J4 wire tie)

4. Grease the inside of the cable protection spring.

C4-A601**:

Grease : Krytox 18 g

Spring : ø17.5 (Length: 130 mm) : 3 g

 ø25 (Length: 130 mm) : 5 g × 2

 ø29 (Length: 130 mm) : 5 g

C4-A901**:

Grease : Krytox 19 g

Spring : ø17.5 (Length: 280 mm) : 4 g

 ø25 (Length: 130 mm) : 5 g × 2

 ø29 (Length: 130 mm) : 5 g

5. Secure the Arm #2 cable fixing plate and the cable unit.

Plate and spring : Wire tie AB100

Cable unit and plate : Wire tie AB150, Mark tube 65 mm

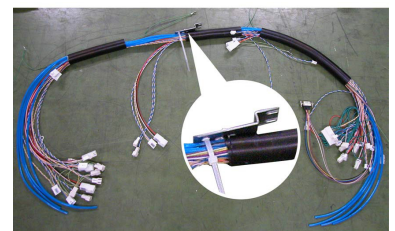

Precautions for cable unit fixation to the plate:

Pass the mark tube and the wire tie through the hole of the plate as shown in the photo on the right.



When installing the cable unit, place the plate, the air tube, and the cables as shown in the photo on the right (example), and then fix the plate and the cable unit with a wire tie.

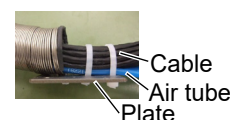

6. Insert the cable unit with the cable protection spring ($\varnothing 17.5$) from the Arm #4.

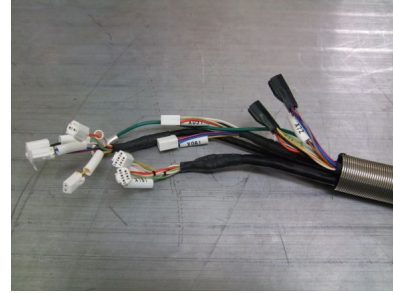

7. Wrap the end of the spring to the Arm #4 cable fixing plate with a wire tie.

Wire tie: AB100 \times 1

Number of turns of spring to fix: 3 turns

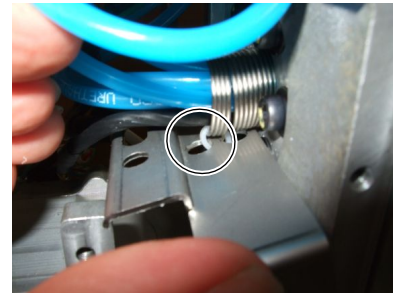

8. Insert the cable unit with the cable protection spring ($\varnothing 29$) from the Arm #1 to the base side.

Connectors to be passed through to the base:

X12, X020, X030, X13, X040, X050, X060,
X14, X15, X16, XGND, BR011, BR010, BT1,
BR020, BR030, BR040, BR050, BR060,
LED, SW1, GS01, GS02

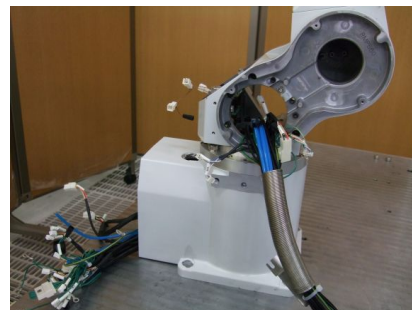
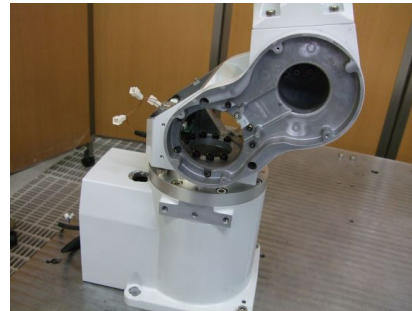

9. Pull the wrapped cables from the Arm #2.

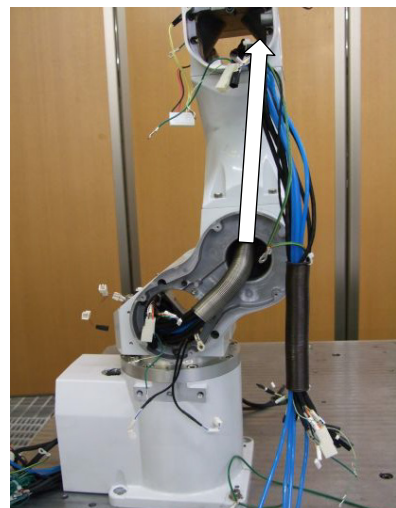

10. Pass the cable unit to the Arm #3.

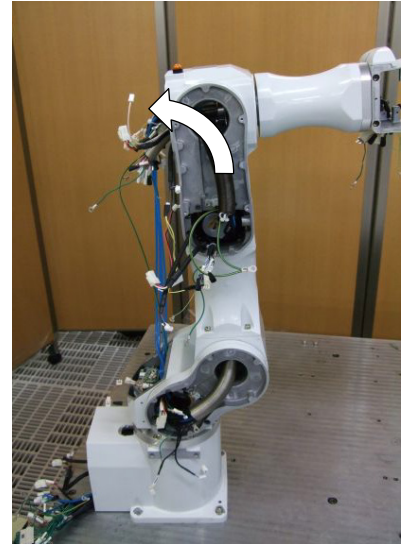

11. Fix the Arm #2 cable fixing plate to the Arm #2.
Hexagon socket head cap bolt: 2-M4×8



12. Fix the cable protection spring ($\phi 25$, 130mm) of the Arm #2 to the Arm #3 cable fixing plate.

Wire tie: AB100

Number of turns of spring to fix: 3 turns



13. Temporarily bind two cables.

Wire tie: AB150 × 2

Mark tube: 57 mm × 2

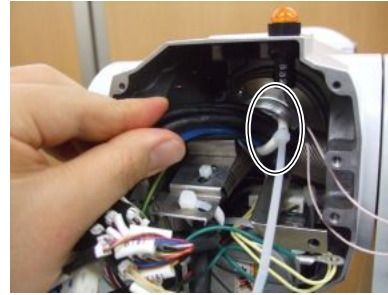

Temporarily bind the cables so that their position can be adjusted later.

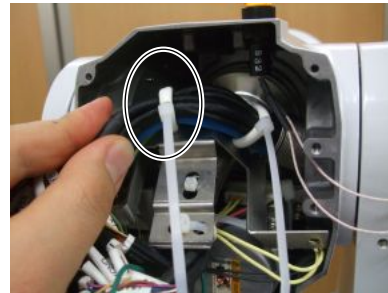

Precautions for cable unit fixation to the plate:

NOTE  Pass the mark tube and the wire tie through the hole of the plate as shown in the photo on the right.



When installing the cable unit, place the plate, the air tube, and the cables as shown in the photo on the right (example), and then fix the plate and the cable unit with a wire tie.

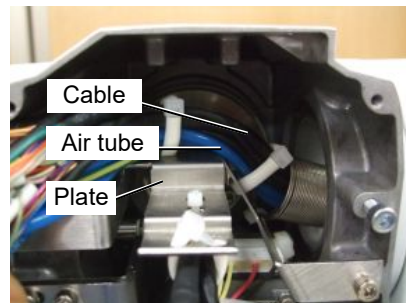

14. Fix the cable protection spring (ø17.5) to the Arm #3 cable fixing plate.

Wire tie: AB100

Number of turns of spring to fix: 3 turns



15. Pass the four air tubes and the ground wire of the cable unit through the cable protection spring ($\varnothing 17.5$) and pull them out from the Arm #4.

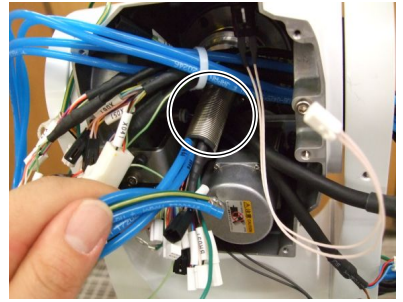

Pass the air tubes through the space on the upper side of the spring.

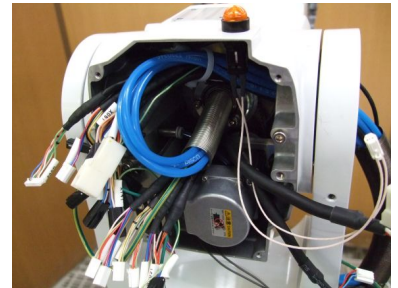

16. Wrap the end of the spring to the fixing plate with a wire tie. (a)
Temporarily bind the cables to the Arm #4 cable fixing plate. (b)

Wire tie: AB150

Silicone sheet: 15 mm \times 50 mm

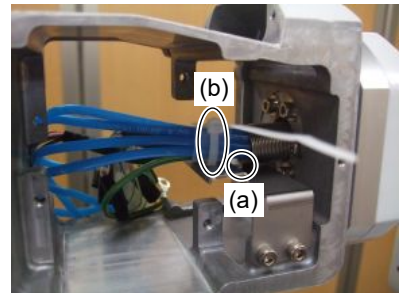

Precautions for cable unit fixation to the plate

NOTE  Place the silicone sheet on the plate as shown in the photo on the right (example). Fix the wire tie at the center of the silicone sheet.



17. Temporarily fix the Arm #4 cable fixing plate to the Arm #4.

Hexagon socket head cap bolt: 2-M4×10

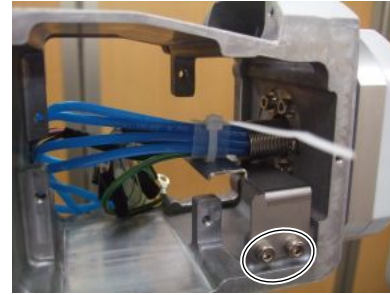

18. Temporarily bind the cables coming from the Arm #4.

Wire tie: AB150

Mark tube: 46 mm



Precautions for cable unit fixation to the plate:

NOTE  Pass the mark tube and the wire tie through the hole of the plate as shown in the right photo.

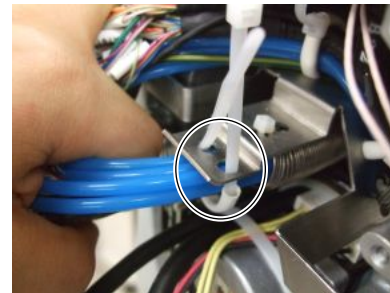

When installing the cable unit, place the plate, the air tube, and the cables as shown in the right photo (example), and then fix the plate and the cable unit with a wire tie.

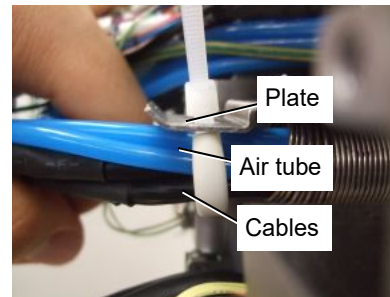

19. Disconnect the D-sub connector to the user plate installation part.

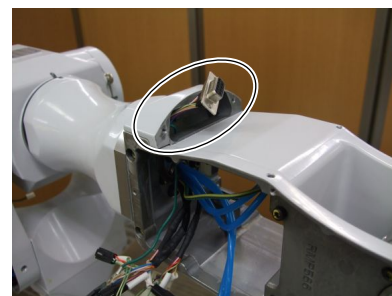

20. Install the D-sub connector to the user plate.

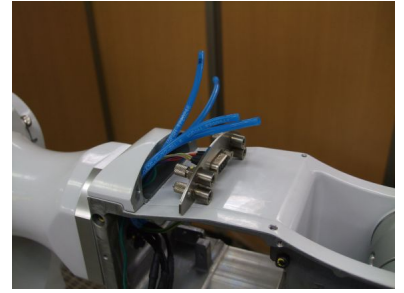

21. Temporarily fix the Arm #3 cable fixing plate to the Arm #3.

Hexagon socket head cap bolt: 2-M4×8

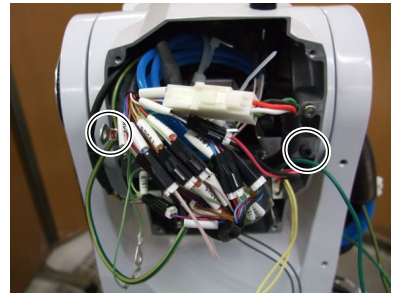

22. Adjust length of each cable and air tube inside the Arm #3.

Length of the cable passed through the Arm #4:

From the Arm #3 cable fixing plate to each connector: 60 mm

Connector: X151, X161*, XGND, X051, X061*, BR051, BR061*, BT51, BT61*, X71, X72*

*: X161, X061, BR061, BT61, and X72 may not be existed.

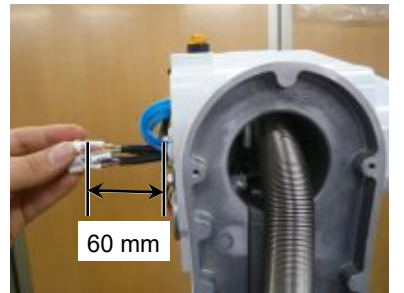

Length of the cable passed through the Arm #3:

From the Arm #3 cable fixing plate to each connector: 50 mm

Connector: X141, X151, X161*, XGND, X041, X051, X061*, BR041, BR051, BR061*, LED, BT4 (BT51, BT61*), X71, X72*

*: X161, X061, BR061, BT61, and X72. may not be existed.

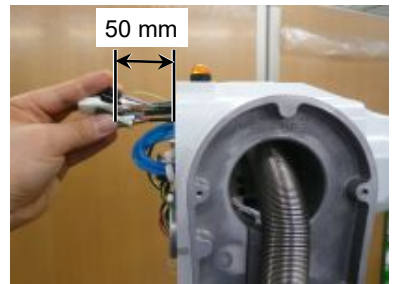

Air tube length:

From the Arm #3 to the air tube: 30 mm

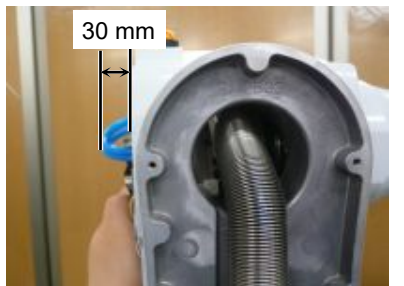

Ground wire length:

From the Arm #3 cable fixing plate

To the ground terminal: 110 mm

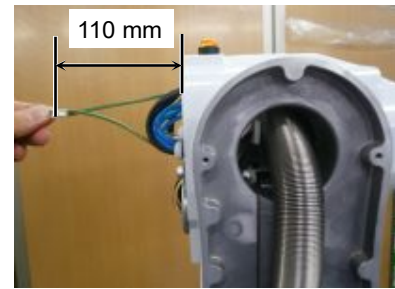

Length of the control board 2 cable passed through the Arm #3:

From the Arm #3 to the control board 2 connector: 100 mm

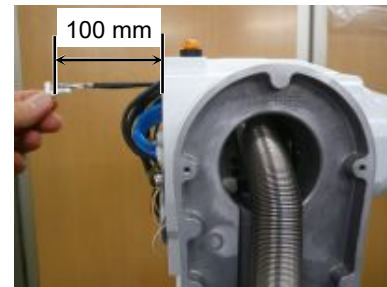

Connector: GS02

23. Fix the cables temporarily fixed with a wire tie.

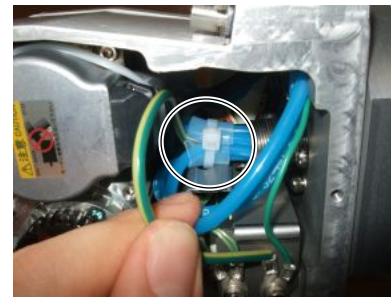

24. Install the ground wires to the fixing screws on the Arm #4 cable fixing plate, and tighten the temporarily fixed screws. Adjust orientation of terminals as shown in the photo.

Circle (right): Ground terminal, user wire's ground terminal

Circle (left): X052/X062 ground terminal,

X152/X162 ground terminal



25. Fix the cables temporarily fixed to the Arm #3 cable fixing plate.



26. Install the D-sub connector to the user plate.

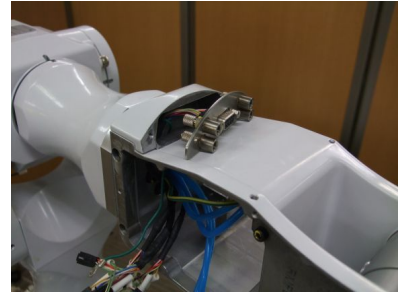

Be careful of the direction of the user plate.

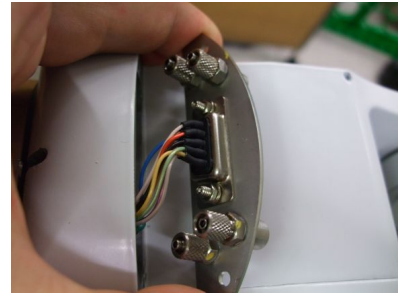

27. Install the air tubes to the user plate fittings.

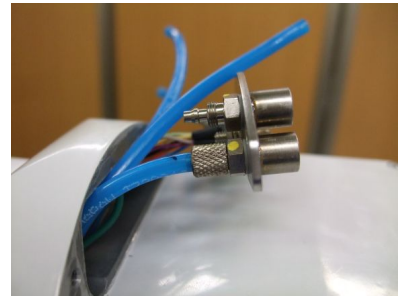

Air tube projection length: 45 mm

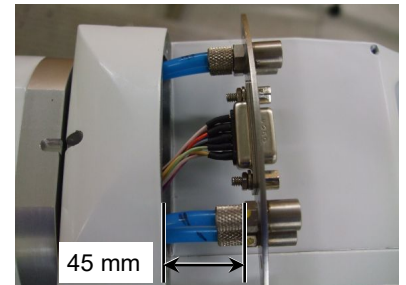

28. Install the user plate to the Arm #4.

Hexagon socket head cap bolt: 2-M3×6



29. Fix the Joint #5 motor unit to the Arm #4 temporarily and place the Joint #5 timing belt on the pulleys.

Hexagon socket head cap bolts: 2-M4×15 (with a plain washer)

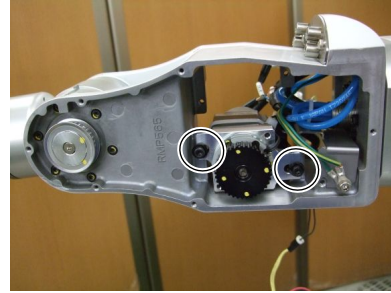

30. Fix the Joint #6 motor unit to the Arm #4 temporarily and place the Joint #5 timing belt on the pulleys.

Hexagon socket head cap bolts: 2-M4×15 (with a plain washer)

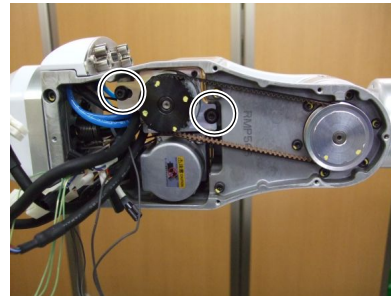

31. Connect the Joint #5 and Joint #6 motor connectors.

Connectors:

X052, X062, X152, X162, BR052, BR062, BT52, BT62

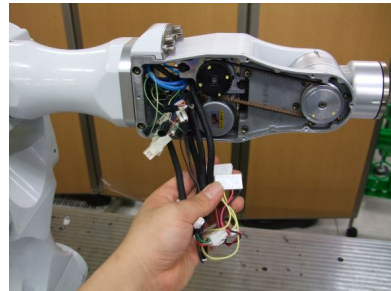

32. Put the connected connectors in the Arm #4.

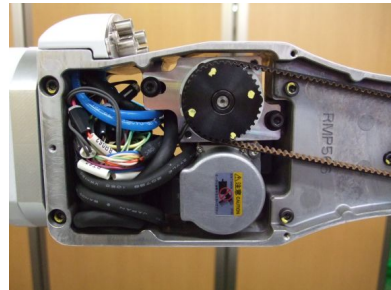

33. Connect the connectors inside the Arm #3.

Hexagon socket head cap bolts: 2-M4×8

Connectors:

X71, X72*, X041, X051, X061*, LED, BR041, BR051, BR061*, BT4, BT51, BT61*, X141, X151, X161*, XGND

*: X72, X061, BR061, BT61, and X161 may not be existed.

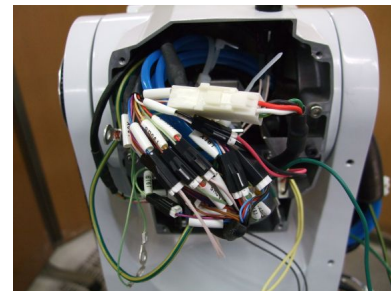

34. Fix the control board 2 to the Arm #3 and connect the connectors.

Control board 2

Hexagon socket head cap bolt: 1-M4×10

Hexagon socket head cap bolt: 1-M3×8

Connector: GS02

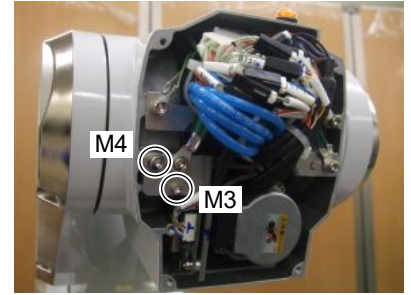

35. Fix the ground wires.

Install the following ground terminals to the parts marked with circles, and fix together with the Arm #3 cable fixing plate. Then, tighten the temporarily fixed bolts.

Circle (right): X71/X72 ground terminals (J3),
X71/X72 ground terminals (J4)

Circle (left): X061* ground terminal, X041 ground terminal

*: Use X051 ground terminal if X061 is not existed.

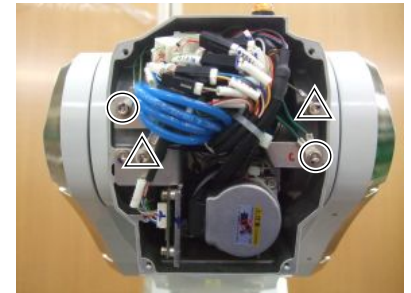

Install the following ground terminals to the parts marked with triangles.

Hexagon socket head cap bolt: 2-M4×8

Triangle (right): X141 ground terminal

Triangle (left): Ground wire terminal

Adjust the orientation of terminals as shown in the photo on the right.

36. Put the cables temporarily fixed to the Arm #3 cable fixing plate together and fix them.

Bind the Arm #3 cables and the connectors with a wire tie.

Wire tie: AB200 (2 ties)

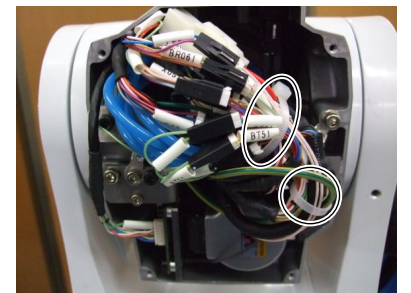

37. Fix the cable protection spring (ø25 Length: 130 mm) to the Arm #2.

Wire tie: AB100 (2 ties)



38. Temporarily fix the cables to the cable binder.

Wire tie: AB150

Mark tube: 21 mm (2 tubes)

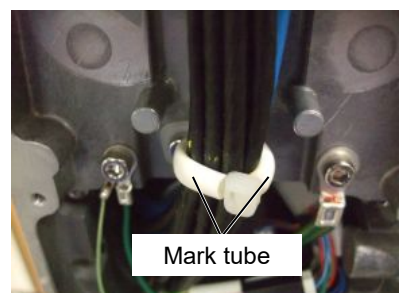

39. Push the cables in the direction of an arrow in the photo on the right, and fix the cable temporarily fixed by the wire tie.

Pushing depth: 10 mm

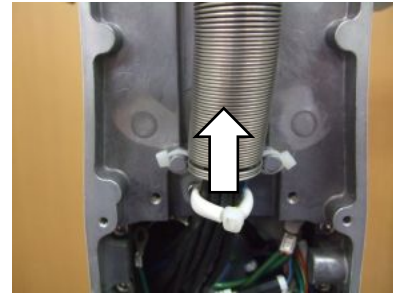

40. Temporarily fix the Joint #3 motor unit to the Arm #2 and place the Joint #3 timing belt to the pulleys.

Hexagon socket head cap bolts: 2-M4×15 (with a plain washer)

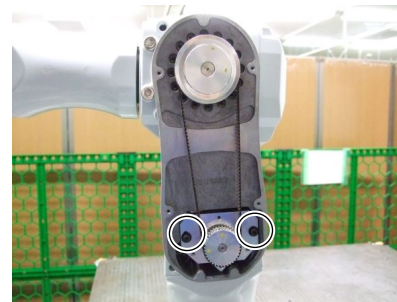

Pass the cables to the left side of the motor's rear side as shown in the photo.

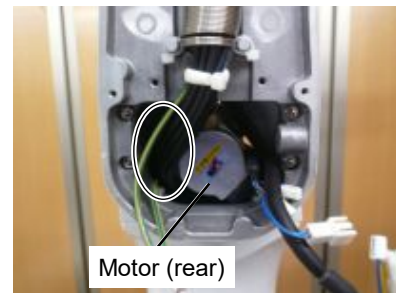

41. Connect the Joint #3 motor connectors and put them in the Arm #2.

Connectors: X031, X131, BR031, BT3

42. Fix two ground wires to the Arm #2.

Hexagon socket head cap bolts: 2-M4×8

Circle (right): X031 ground terminal, X131 ground terminal

Circle (left): Ground wire terminal



43. Fix the cable protection spring (ø 25 Length: 130 mm) to the Arm #1.

Wire tie: AB100 (2 ties)



44. Temporarily fix the cables to the cable binder.

Wire tie: AB150

Mark tube: 23 mm (2 tubes)



45. Push the cable in the direction of an arrow in the photo on the right, and fix the cable temporarily fixed by the wire tie.

Pushing depth: 6 mm



46. Fix the cable protection spring (ø25, 130 mm) to the Arm #1 cable fixing plate.

Wire tie: AB100 (2 ties)

Number of turns of spring to fix: 3 turns



47. Temporarily fix the cables to the Arm #1 cable fixing plate.

Wire tie: AB150 (2 ties)

Mark tube: 68 mm (2 tubes)



Set the heads of the wire ties to the side of the cables as shown in the photo on the right.



48. Fix the Arm #1 cable fixing plate to the Arm #1.

Hexagon socket head cap bolt: M4×8, M6×20
 M6 tightening torque: 17.6 N·m (180 kgf·cm)

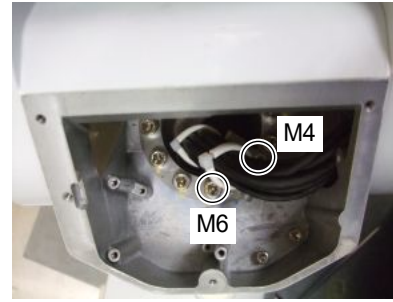

49. Fix the cables temporarily fixed by the wire tie.



Precautions for cable unit fixation to the plate:

NOTE  For the upper side, pass the mark tube and the wire tie through the hole of the plate and wrap around the cutout. For the lower side, pass the other mark tube and the wire tie through the hole of the plate, as shown in the photo on the right.



When installing the cable unit, place the plate, the air tube, and the cables as shown in the photo on the right (example), and then fix the plate and the cable unit with a wire tie.

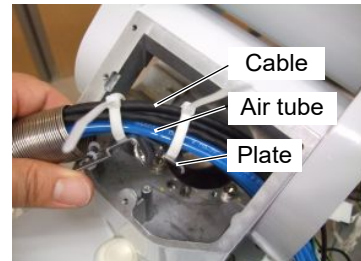

50. Temporarily fix the Joint #2 motor unit to the Arm #1 and place the Joint #2 timing belt to the pulleys.

Hexagon socket head cap bolts: 3-M4×15 (with a plain washer)

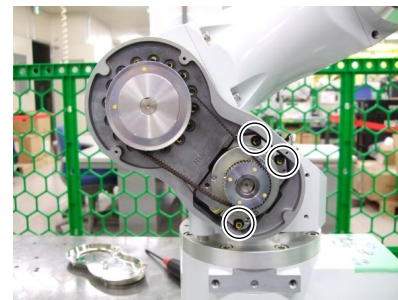

51. Connect the Joint #2 motor connectors and put them in the Arm #2.

Connector: X021, X121, BR021, BT2

52. Fix the ground wires to the Arm #2.

Hexagon socket head cap bolts: 2-M4×8
 Circle (right): X021 ground terminal, X121 ground terminal
 Circle (left): ground wire terminal

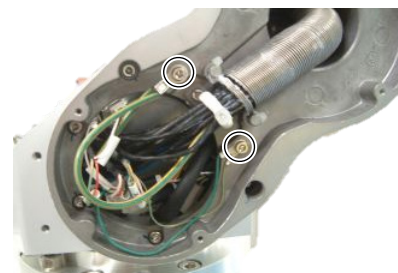

53. Install the battery board.

Hexagon socket head cap bolts: 2-M3×8



54. Install the connector to the battery board.

Connector: CN3



55. * If you are not replacing the battery relay cable, go to the step (56).

If replacing the battery relay cable:

Install the connectors to the battery unit.

Connector: BT (2 connectors)

(The connectors can be installed on either side)

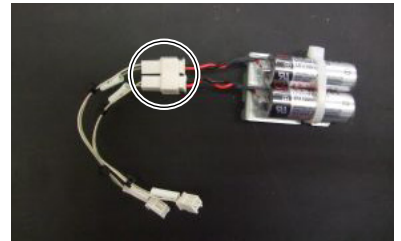

56. Install the connectors to the battery board.

Connector: 2 connectors for the batteries, BT-CN1, BT-CN2, CN3

Wire tie: AB100



57. Install the control board 1 to the Arm #1 and connect the connector.

Cross recessed head screws: 3-M3×8

Connector: GS01



58. Bind the cable protection spring (ø29, 130 mm) to the base cable fixing plate.

Wire tie: AB100

Number of turns of spring to fix: 3 turns

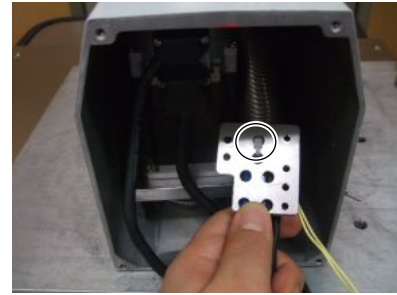

59. Wrap the silicone sheet around the cables as shown in the photo on the right.

Silicone sheet: 30 mm × 150 mm



60. Temporarily bind the cables wrapped with the silicone sheet to the base cable fixing plate.

Wire tie: AB150 (2 ties)



Precautions for cable unit fixation to the plate



When installing the cable unit, place the plate, the air tube, and the cables as shown in the photo on the right (example), and then fix the plate and the cable unit with a wire tie.

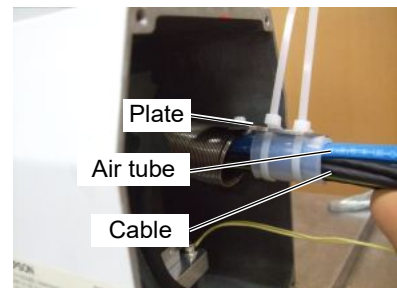

Fix the cables with the wire ties so that the silicone sheet projects 5 mm from the base cable plate.

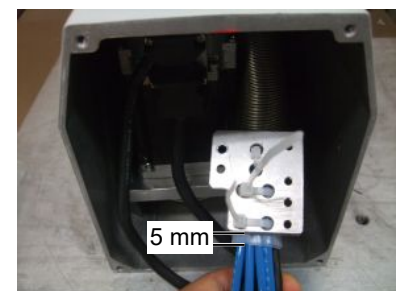

61. Pull the cable out and adjust the plate position.

Plate position: 15 mm

Fix the cable temporarily fixed by the wire tie.

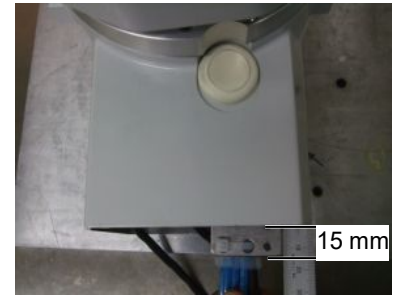

62. Fix the base cable fixing plate to the base.

Hexagon socket head cap bolt: 2-M4×8



63. Fix the ground wires to the base cable fixing plate.

Fix the ground wire terminal to the upper circled part.

Fix the other ground terminals coming from the connectors to the lower circled part.

Bind two ground wires together and fix to the three screw points.

Hexagon socket head cap bolts: 4-M4×8

Adjust orientation of the terminals and fix them as shown in the photo on the right.



64. Cut the air tubes to the same length
(about 70 mm from the end surface of the base).

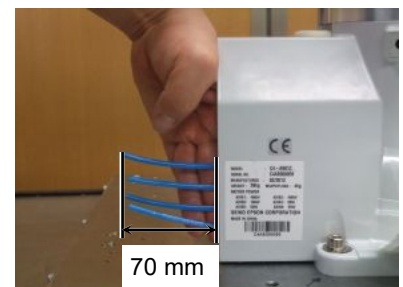

65. Insert the air tubes to the air tube fitting on the connector plate.

66. Connect the connectors to the M/C cable.

Connector:

X010, X020, X030, X040, X050, X060,
LED, BR010, BR011, BR020, BR030,
BR040, BR050, BR060,
BT1, X11, X12, X13, X14, X15, X16, XGND,
GS01, GS02



67. Connect the D-sub 9-pin connector and the D-sub 15-pin connector to the connector plate.

68. Apply tension to the Joint #5 motor unit and fix it.

For details, refer to *Maintenance: 9.1 Joint #5 – Replacing the Motor*, Installation step 6.

69. Apply tension to the Joint #6 motor unit and fix the joint #6 motor unit.

For details, refer to *Maintenance: 10.1 Joint #6 – Replacing the Motor*, Installation step 6.

70. Apply tension to the Joint #3 motor unit and fix it.

For details, refer to *Maintenance: 7.1 Joint #3 – Replacing the Motor*, Installation step 6.

71. Apply tension to the Joint #2 motor unit and fix it.

For details, refer to *Maintenance: 6.1 Joint #2 – Replacing the Motor*, Installation step 6.

72. Mount the following covers and plates.

Arm #3 head cover	Arm #3 bottom cover
Arm #2 side cover (Both sides)	Arm #1 side cover (Both sides)
Arm #1 top cover	Connector plate

For details, refer to *Maintenance: 3. Covers*.

73. Perform the calibration.

For details, refer to *Maintenance: 16. Calibration*.

4.2 Connector Pin Assignments

4.2.1 Signal Cable

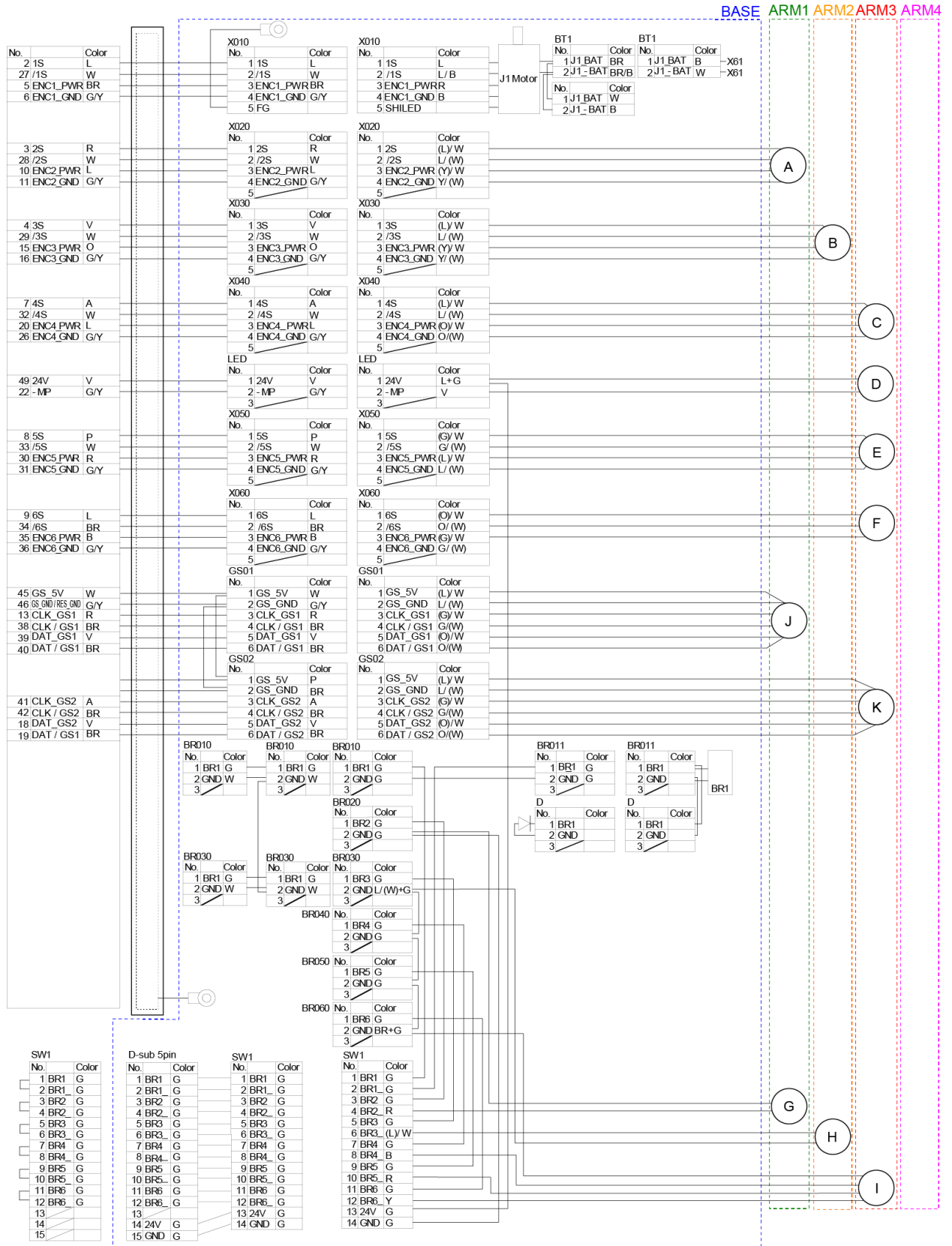

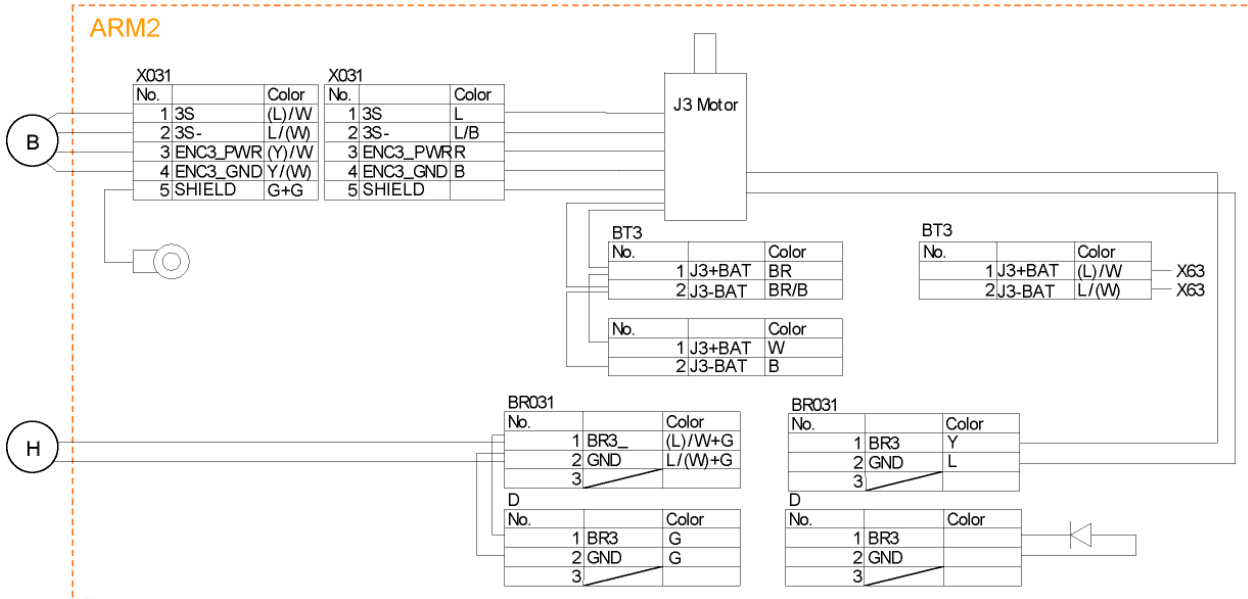
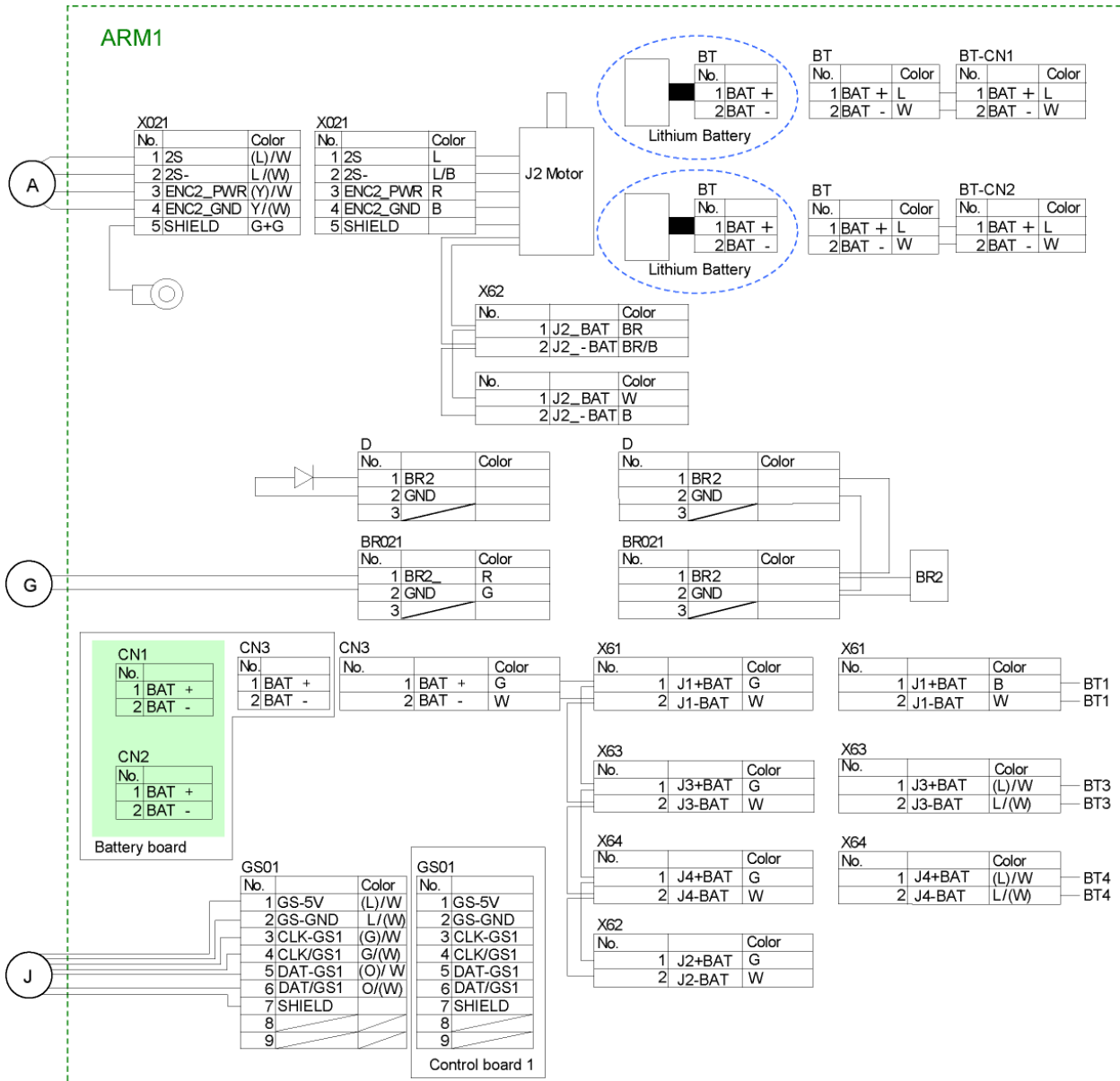

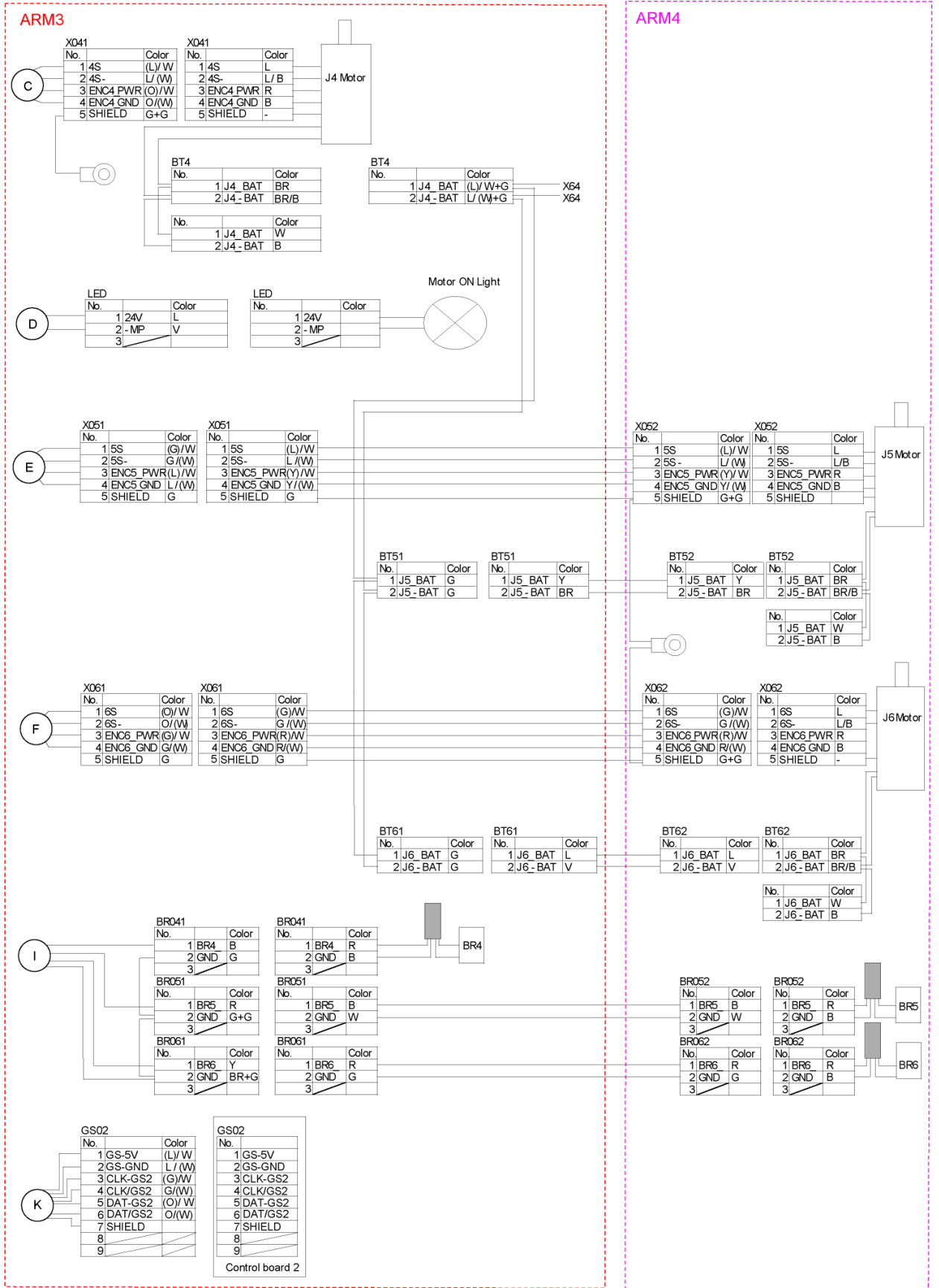

Maintenance 4. Cable Unit

* For specifications without connector X061, BT61, BR061, X161, X72.



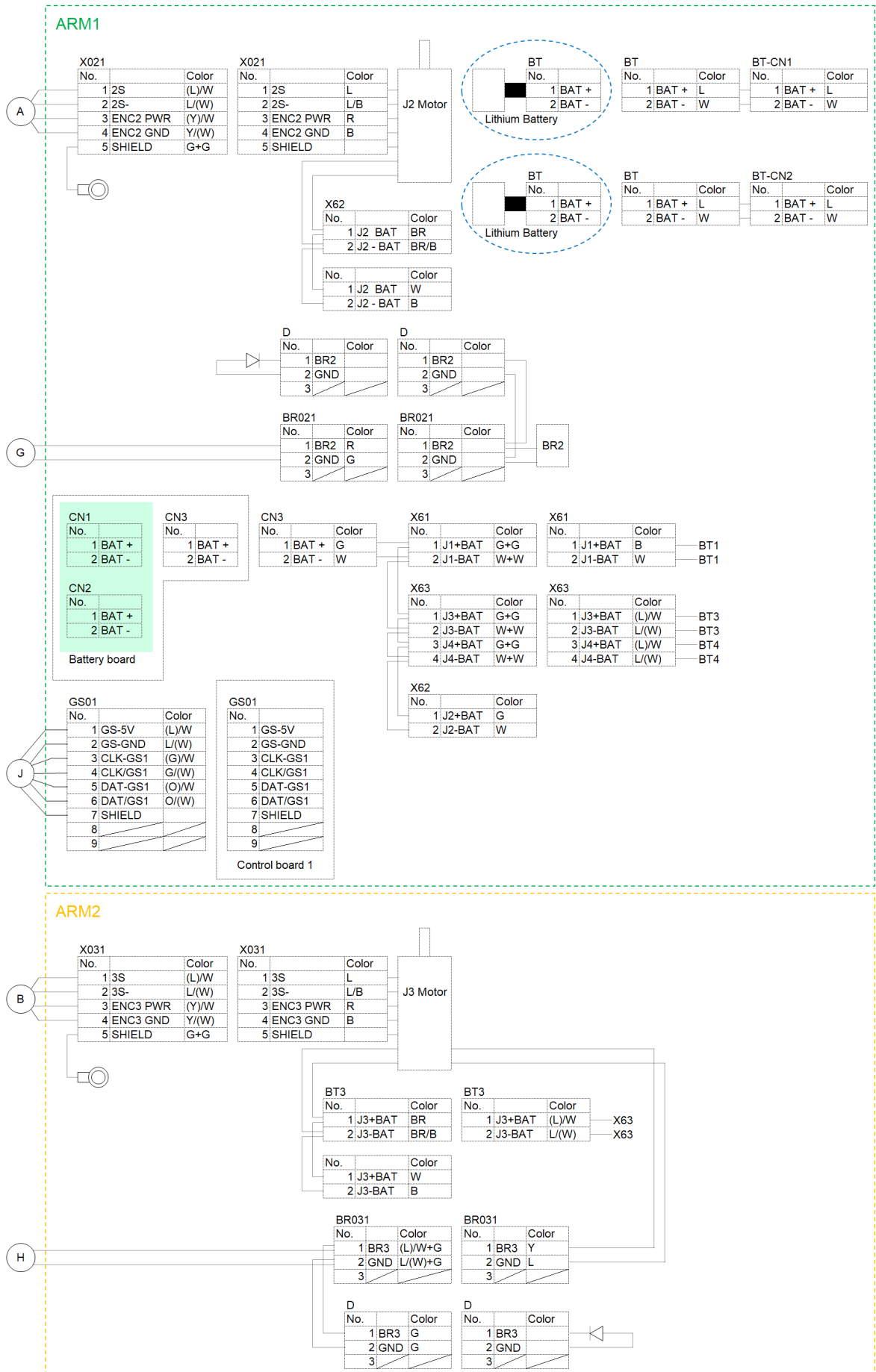

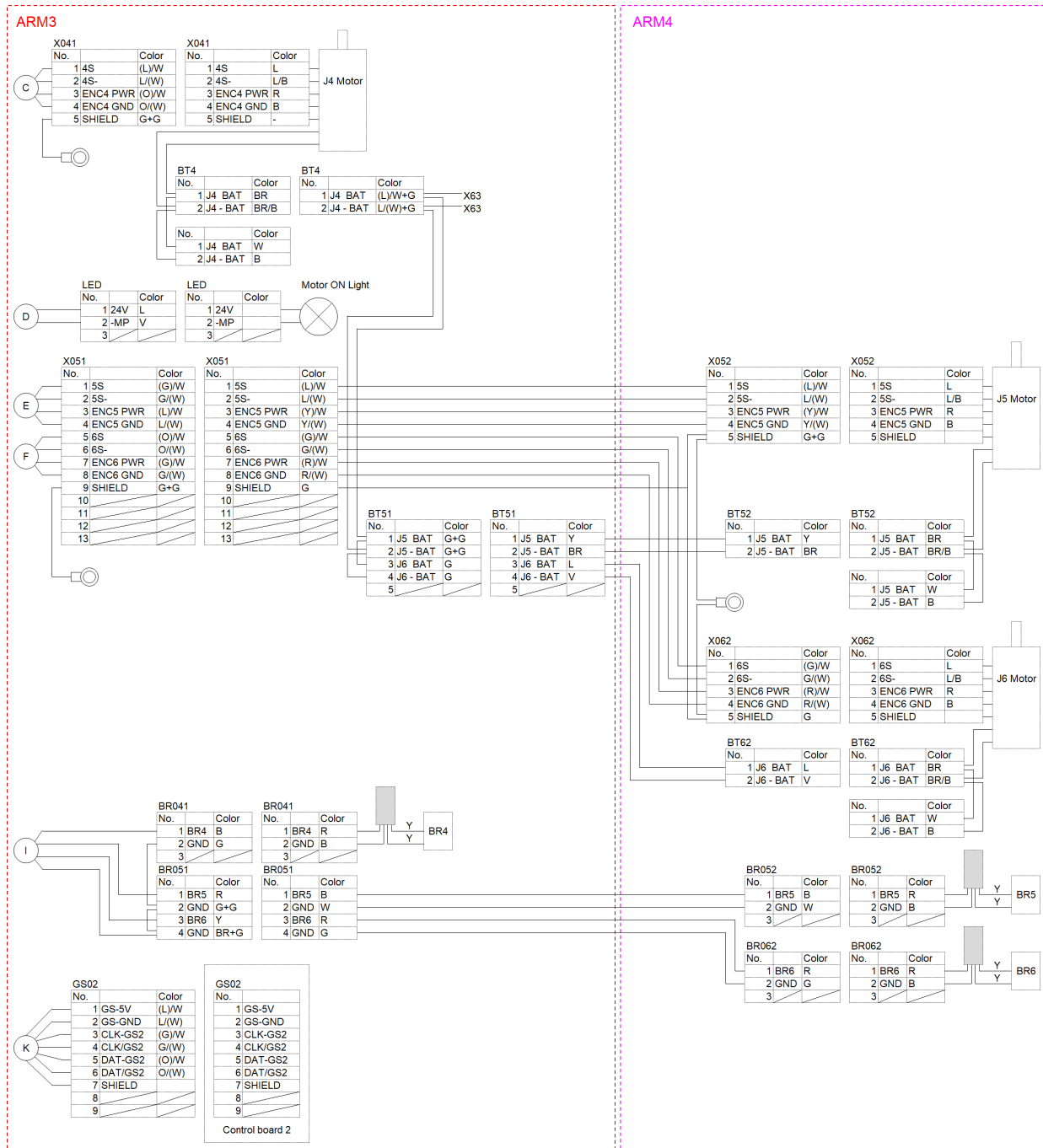

4.2.2 Power Cable

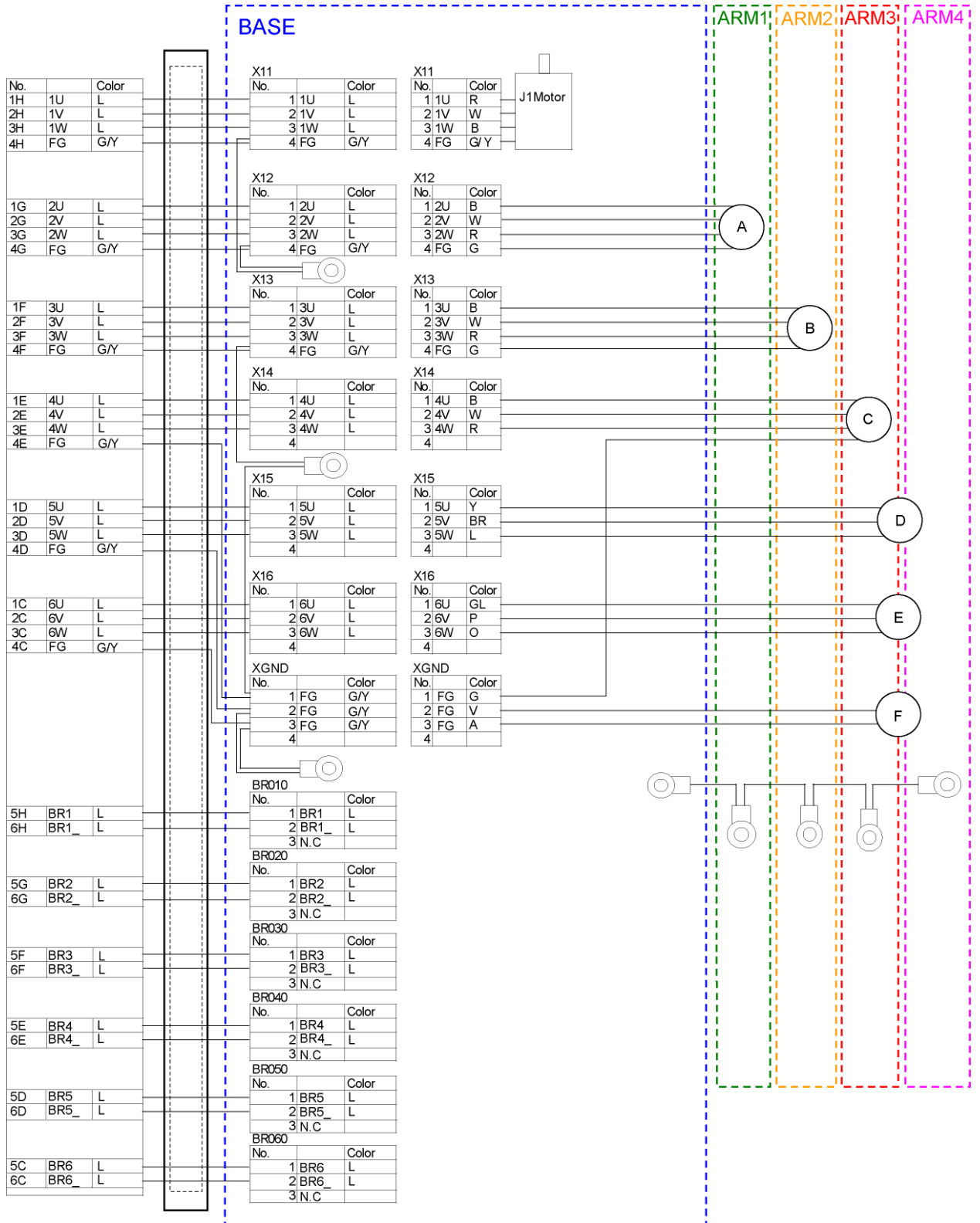

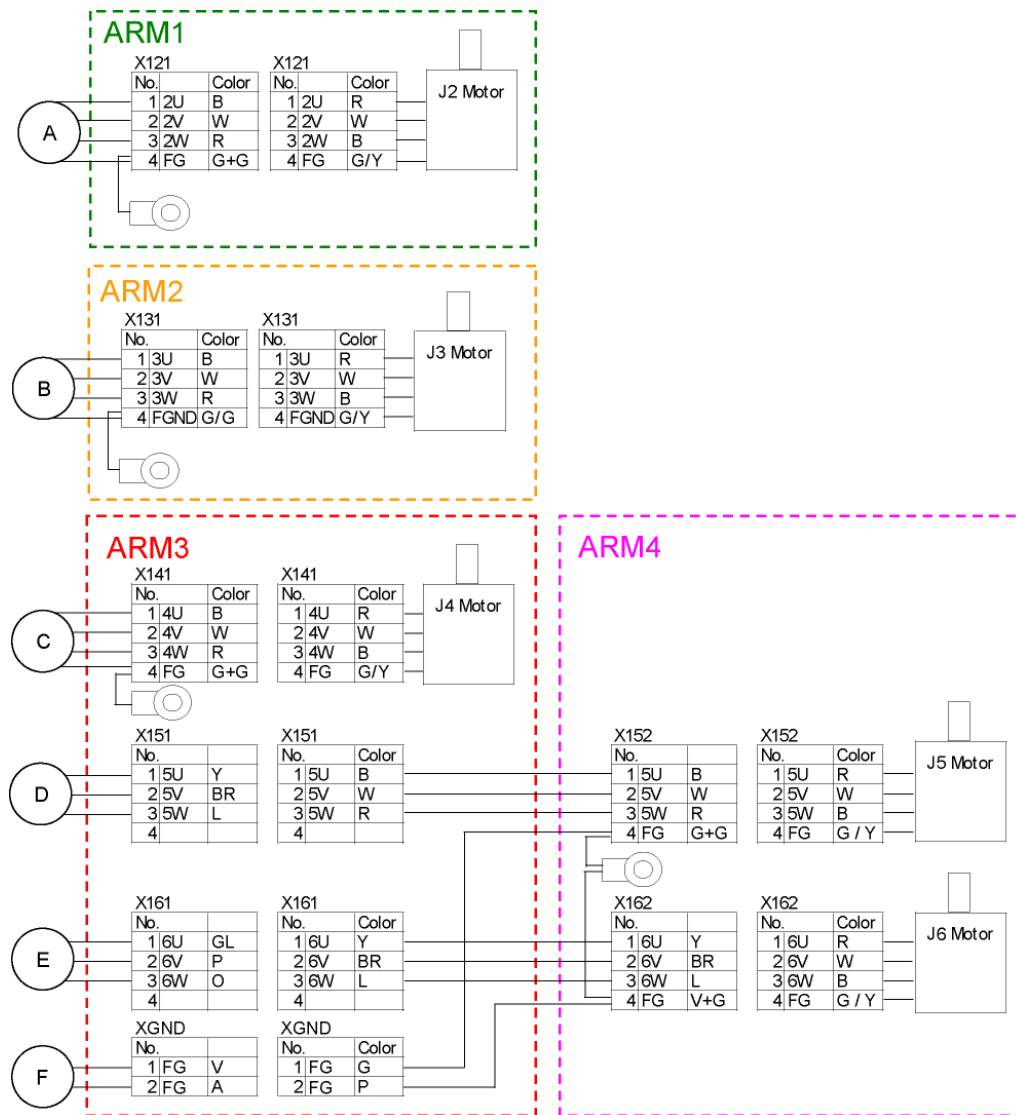

* For specifications without connector X061, BT61, BR061, X161, X72.

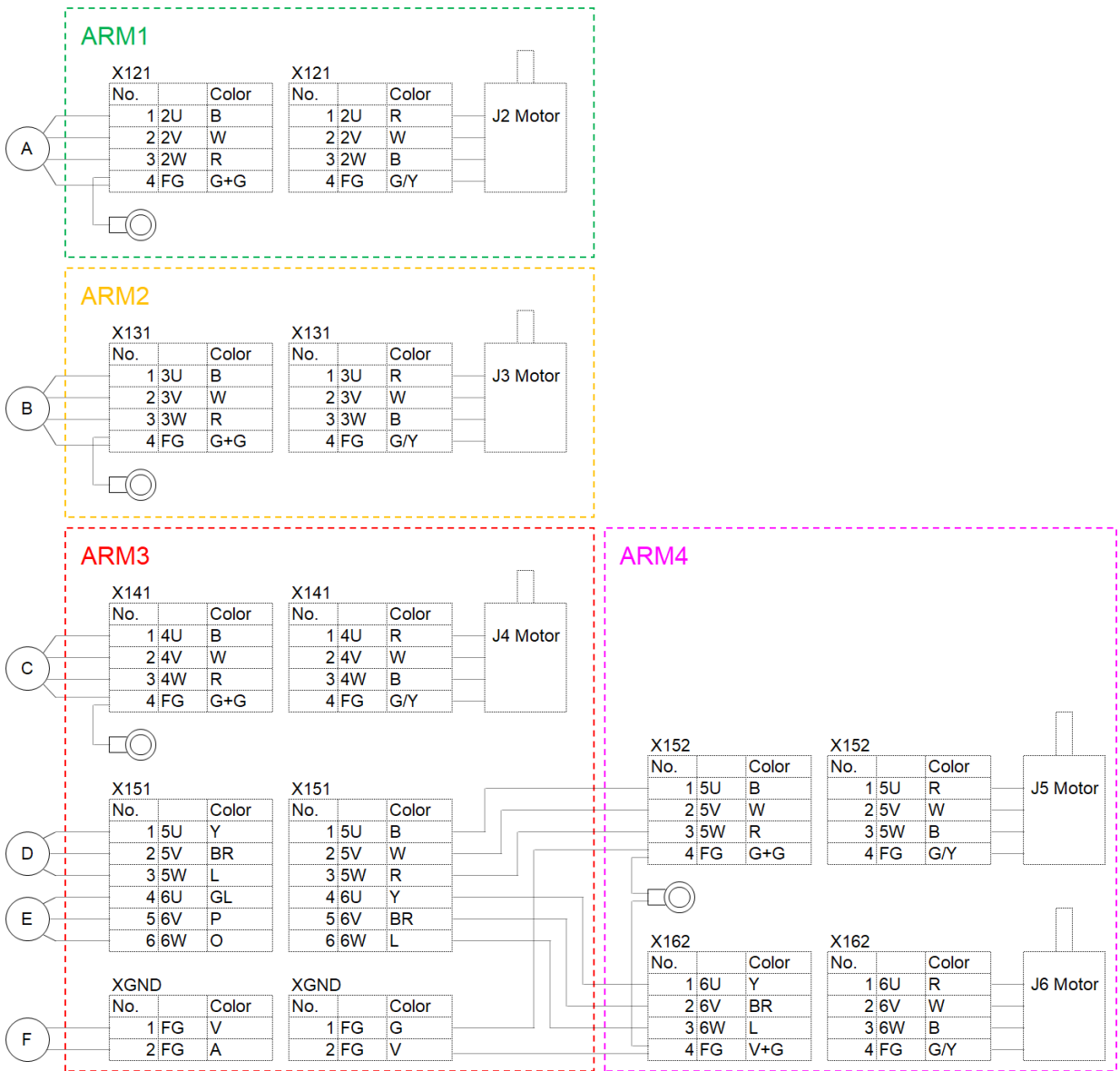

4.2.3 User Cable



* For specifications without connector X061, BT61, BR061, X161, X72.

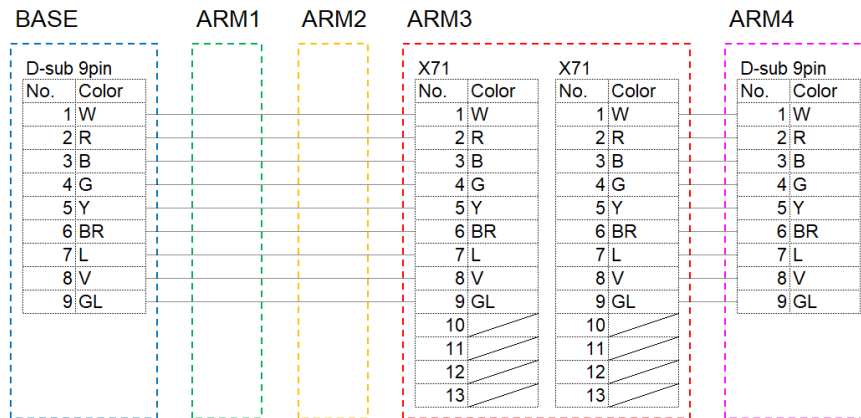

4.2.4 Color of Cables

The following table shows the codes and cable colors indicated in the pin assignments.

- 4.2.1 Signal Cable
- 4.2.2 Power Cable
- 4.2.3 User Cable

Code	Cable color
B	Black
W	White
R	Red
G	Green
Y	Yellow
BR	Brown
L	Blue
V	Violet
A	Azure
O	Orange
GL	Gray
P	Pink

5. Joint #1



- Before performing any replacement procedure, turn OFF the Controller and related equipment, and then disconnect the power plug from the power source. Performing any replacement procedure with the power ON is extremely hazardous and may result in electric shock and/or malfunction of the robot system.
- Do not connect or disconnect the motor connectors while the power to the robot system is turned ON. Connecting or disconnecting the motor connectors with the power ON is extremely hazardous and may result in serious bodily injury as the Manipulator may move abnormally, and also may result in electric shock and/or malfunction of the robot system.
- Be sure to connect the AC power cable to a power receptacle. DO NOT connect it directly to a factory power source. To shut off power to the robot system, disconnect the power plug from the power source. Performing any work while connecting the AC power cable to a factory power source is extremely hazardous and may result in electric shock and/or malfunction of the robot system.



- Be careful not to apply excessive shock to the motor shaft during replacement procedures. The shock may shorten the life of the motors and encoder and/or damage them.
- Never disassemble the motor and encoder. Disassembled motor and encoder will cause a positional gap and cannot be used again.

After parts have been replaced (motors, reduction gear units, timing belts, etc.), the Manipulator cannot perform positioning properly because a gap exists between the origin stored in each motor encoder and its corresponding origin stored in the Controller.

After replacing the parts, it is necessary to match these origins.

The process of aligning the two origins is called “Calibration”.

Refer to *Maintenance 16. Calibration* and follow the steps to perform the calibration.

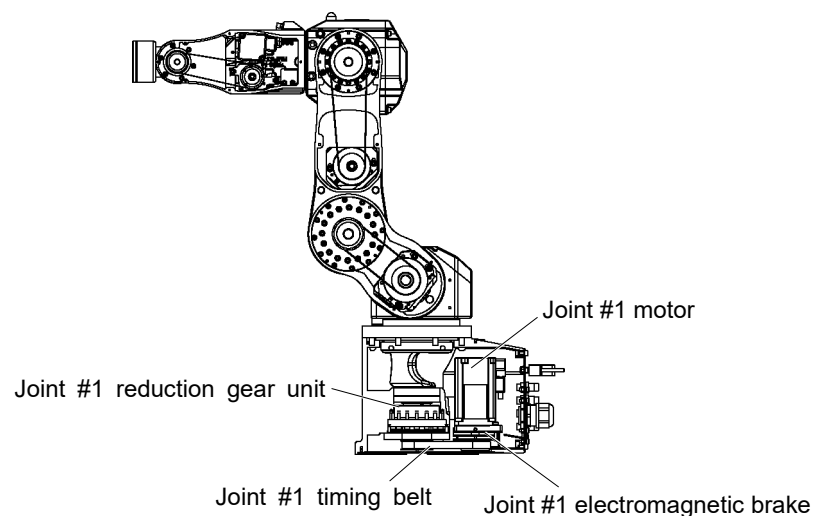

5.1 Joint #1 - Replacing the Motor

	Name		Quantity	Note
Maintenance Parts	AC servo motor 400 W		1	2150748
Tools	Hexagonal wrench	width across flats: 2.5 mm	1	For M5 hexagon socket head set screws
		width across flats: 3 mm	1	For M4 hexagon socket head cap bolts
		width across flats: 4 mm	1	For M5 hexagon socket head cap bolts
	Cross-point screwdriver		1	For covers
	Torque wrench		1	
Force gauge		1	For belt tension adjustment	

Removal: Joint #1 Motor

1. Turn ON the Controller.
2. Remove the connector plate.

For details, refer to *Maintenance: 3. Covers*.

3. Disconnect the connectors.

Connector: X11, X010, BT1, BR011
(Hold the clip to remove.)

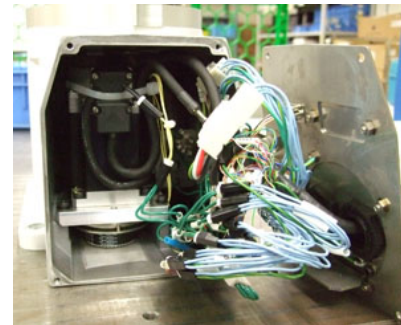

4. Remove the Joint #1 motor unit from the base.
Hexagon socket head cap bolts: 3-M4×20 (with a plain washer)

To remove the screw fixed to the rear of the motor unit (B), put a hexagonal wrench through the hole (A) after removing the cap.

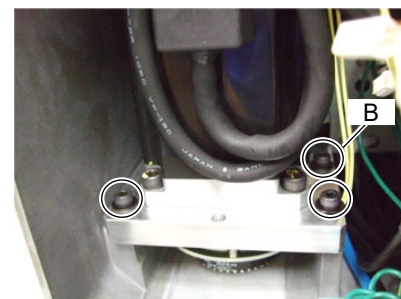
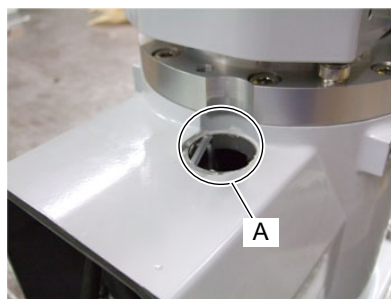
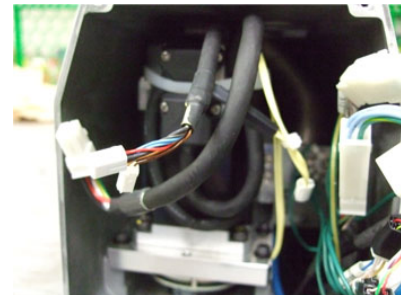

5. Remove the pulley 1 and the drive boss from the Joint #1 motor unit.

Drive boss and the pulley:

Hexagon socket head set screws: 2-M5×6 (with a brass bushing)

Pulley and the motor shaft:

Hexagon socket head set screws: 2-M5×10 (with a brass bushing)

There is a brass bushing on one of the set screws fixing the drive boss and the pulley 1. Be careful not to lose it.

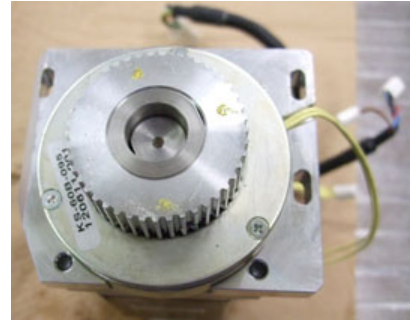

6. Remove the electromagnetic brake of the Joint #1.

Hexagon socket head set screw: 1-M5×8

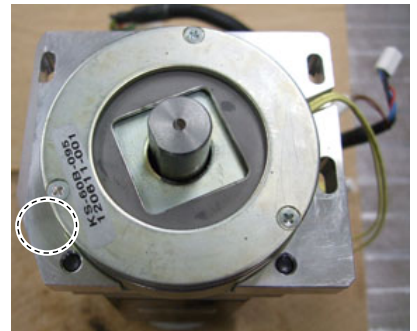

7. Remove the motor plate from the Joint #1 motor.

Hexagon socket head cap bolts: 4-M5×15



Installation: Joint #1 Motor

1. Mount the motor plate to the Joint #1 motor.

Hexagon socket head cap bolts: 4-M5×15
 Tightening torque: 9.8 N·m (100 kgf·cm)

Be careful of the direction of the motor plate. (See the photo.)

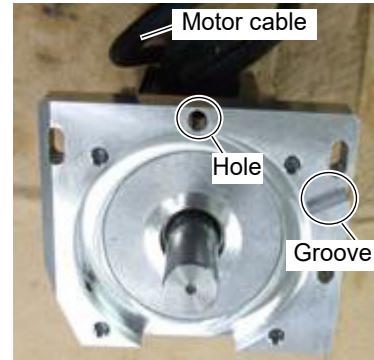

2. Install the electromagnetic brake of the Joint #1 to the Joint #1 motor unit.

Be careful of the direction of the electromagnetic brake.
 Align the wiring position of the brake and the clearance groove on the motor plate. Fix the flat surface of the electromagnetic brake to the set screw side.

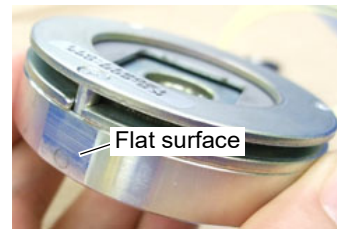

Be careful not to cut the cable by getting it caught between the brake and the plate.

Secure the set screw while pressing the electromagnetic brake to the motor plate.

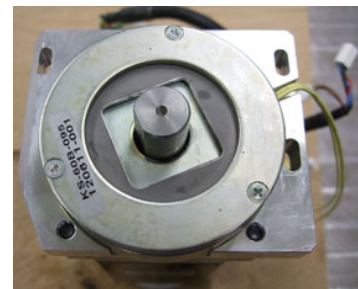

Hexagon socket head set screw: 1-M5×8
 Tightening torque: 3.9 N·m (40 kgf·cm)

3. Install the drive boss and the pulley 1 to the Joint #1 motor unit.

Fix the drive boss and the pulley 1 with the end surfaces of each part together.

Hexagon socket head set screws: 2-M5×6 (with a brass bushing)
 Tightening torque: 3.9 N·m (40 kgf·cm)

Fix the pulley 1 and the motor shaft.

Leave 0.5 mm between the electromagnetic brake and the pulley.
 Refer to the photo for layout of the set screws.

Hexagon socket head set screws: 2-M5×10 (with a brass bushing)
 Tightening torque: 3.9 N·m (40 kgf·cm)

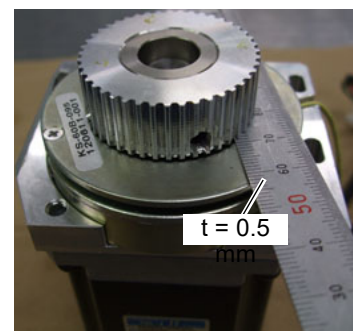
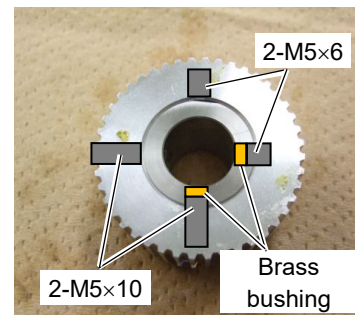

4. Put the Joint #1 timing belt to the Joint #1 pulley 2 on the Joint #1 side.

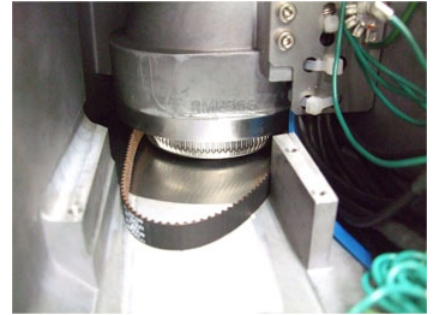

5. Pass the pulley 1 of the Joint #1 motor unit to the Joint #1 timing belt and loosely secure it to the base.
Hexagon socket head cap bolts: 3-M4×20 (with a plain washer)

Make sure that the gear grooves of the timing belt are fit into those of the pulley completely.

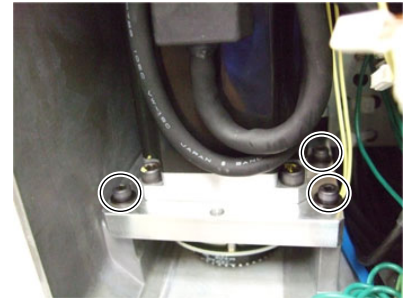

When securing the motor unit loosely, make sure that the motor unit can be moved by hand and it does not tilt when being pulled. If the unit is secured too loose or too tight, the belt will not have proper tension.

6. Apply proper tension to the Joint #1 motor unit and secure it.

Pass a suitable cord or a string (insulation lock) to the drilled hole on the motor plate. Pull the cord using a force gauge or a similar tool to apply specified tension.

Joint #1 timing belt tension: $78.4 \text{ N} \pm 9.8 \text{ N}$ (8 kgf \pm 1 kgf)

Apply proper tension to the Joint #1 motor unit and secure it.

Hexagon socket head cap bolt: 3-M4×20
(with a plain washer)

Tightening torque: $4.9 \text{ N}\cdot\text{m}$ (50 kgf·cm)



7. Connect the following connectors.
Connectors: X11, X010, BT1, BR011
8. Mount the connector plate.
For details, refer to *Maintenance: 3. Covers*.
9. Calibrate the Joint #1.
For details, refer to *Maintenance: 16. Calibration*.

5.2 Joint #1 - Replacing the Reduction Gear Unit

The shapes and replacement procedures of the reduction gear units vary depending on the specification type. The reduction gear units have the following two specification types which differ depending on the time of shipment.

Before performing maintenance, confirm the specification type of the reduction gear unit.

Specification type (1)



Specification type (2)



A reduction gear unit consists of the following parts and accessories. When replacing the reduction gear unit, be sure to replace these parts and accessories all together as a set.

Reduction gear unit : Wave generator, Flexspline, Circular spline

Accessory : Spacer, Grip ring (only for Specification type 1)

For details, refer to *Maintenance: 17. Maintenance Parts List*.

It is recommended to replace the O-ring when replacing the reduction gear unit.

	Name		Quantity	Note
Maintenance Parts	Joint #1 reduction gear unit		1	1687022
	Joint #1 O-ring		1	1480857
Tools	Hexagonal wrench	width across flats: 2.5 mm	1	For M5 hexagon socket head set screws
		width across flats: 3 mm	1	For M4 hexagon socket headcap bolts
		width across flats: 5 mm	1	For M6 hexagon socket headcap bolts
	Cross-point screwdriver		1	For covers
	Torque Wrench		1	
	Spatula		1	For greasing
	Force gauge		1	For belt tension adjustment
Wiping cloth		2	For wiping grease	

Removal: Joint #1 Reduction gear unit

1. Turn OFF the Controller.
2. Turn the Manipulator laterally.



- When turning the Manipulator laterally, there must be two or more people to work on it so that at least one of them can support the arm while the others are removing the bolts. Removing the bolts without supporting the arm may result in the arm falling, bodily injury, and/or malfunction of the robot system.

3. Remove the connector plate and the base bottom cover.
For details, refer to *Maintenance: 3. Covers*.
4. Loosen the set screws of the Joint #1 motor unit and remove the Joint #1 timing belt.

Hexagon socket head cap bolt: 3-M4×20

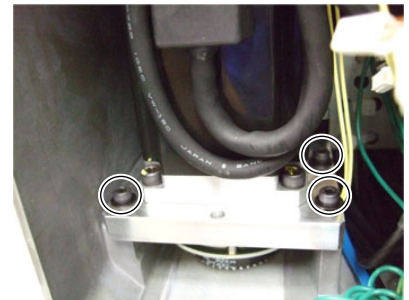

5. Remove the pulley 2.

Hexagon socket head set screw: 2-M5×10 (with a brass bushing)

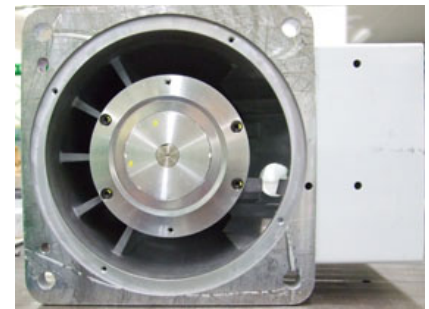

6. Remove the flange.

Hexagon socket head cap bolt: 4-M4×15

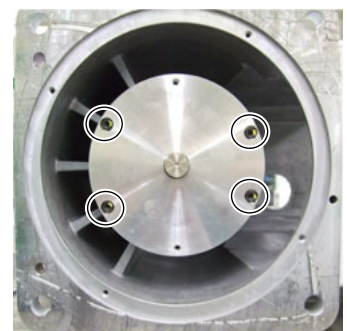

If it is difficult to remove the flange, insert the bolts to two parts as shown in the photo, and then tighten them evenly to remove the flange.

Use the dedicated screws for fixing the flange.

Wipe grease from the parts while removing them.

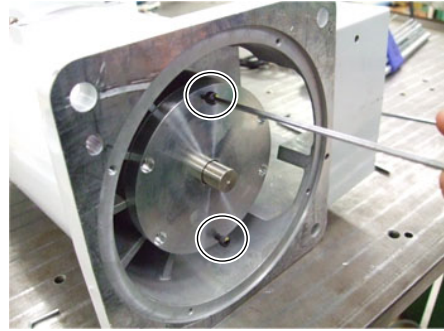

- 7. Remove the O-ring.

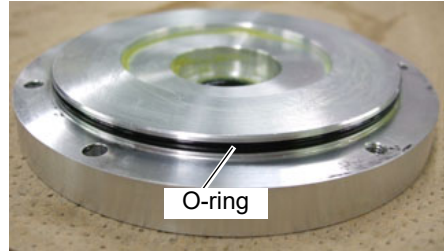

- 8. Remove the wave generator unit from the reduction gear unit.

Wipe grease from the parts while removing them.

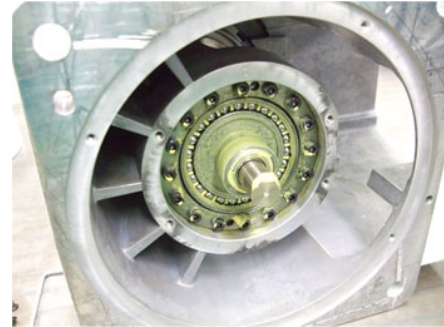

If it is difficult to remove the wave generator unit, install the removed pulley 2 to the shaft and pull the parts together.



- 9. Remove the wave generator from the shaft.

Hexagon socket head set screws: 2-M5×6 (with a brass bushing)

At this point, remove the bearing first. The bearing will be used again. Be careful not to lose it.

There is a brass bushing on one of the set screws. Be careful not to lose it.

Wipe grease from the parts while removing them.



10. Remove the circular spline from the base.

Hexagon socket head cap bolt: 16-M4×20

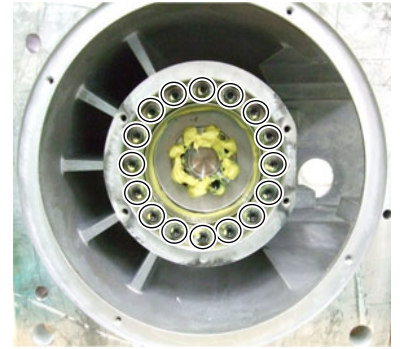

Insert the screws to two parts on the circular spline as shown in the photo. Tighten them evenly and remove the circular spline.

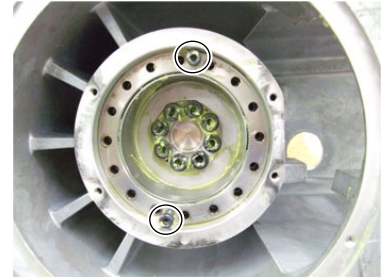

11. Remove the flexspline from the base.

Hexagon socket head cap bolt: 6-M6×15

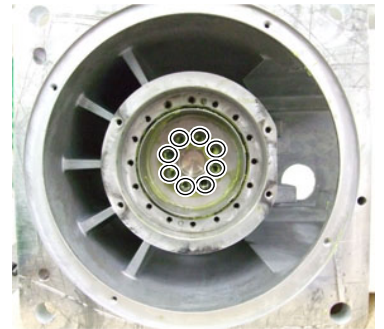

12. Remove the friction plate (EKagrip) between the flexspline installation surface and the flexspline.

This step is not necessary for the Manipulator with a serial number C40E004191 or later since a friction plate (EKagrip) is not included in the part.



13. Wipe grease using a cloth or similar material if it is attached to the base.

Installation: Joint #1 Reduction gear unit

1. Unpack the new reduction gear unit package and check if it contains the parts below.

Specification type (1)

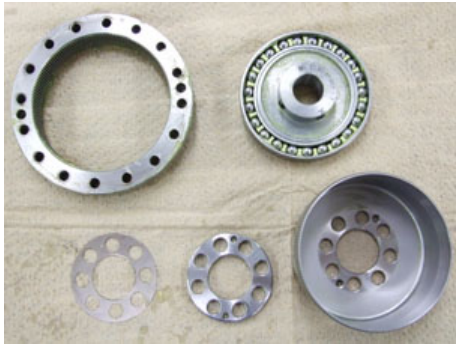

Specification type (2)



2. Place the friction plate (EKagrip) on the end face of the shaft to match the screw holes.

This step is not necessary for the specification type (2) since the friction plate (EKagrip) is not included in the part.

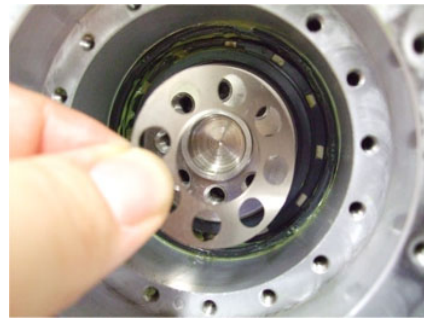

3. Apply grease all over the tooth flank of the flexspline.

Grease: SK-1

Grease amount: enough to fill in the grooves



4. Install the flexspline to the shaft end face.
Insert the spacer between the screws and the part.

Hexagon socket head cap bolt: 6-M6×15
Tightening torque: 17.6 N·m (180 kgf·cm)

Install the flexspline to match the air escapement holes of the flex spline with these of the spacer.

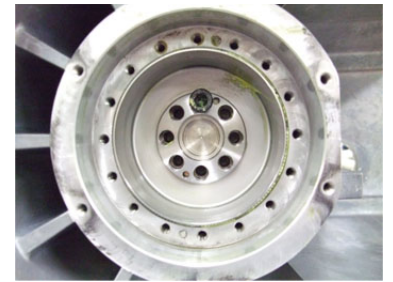
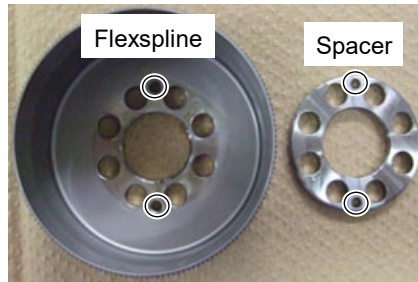
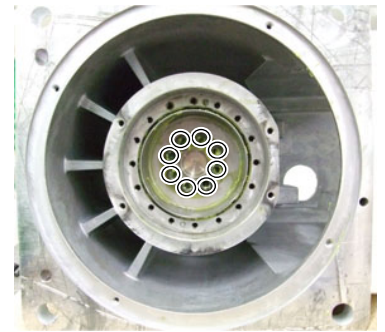

5. Apply grease all over the tooth flank of the circular spline.

Grease: SK-1A
Grease amount: enough to fill the grooves



6. Install the circular spline.

Hexagon socket head cap bolt: 16-M4×20
Tightening torque: 4.9 N·m (50 kgf·cm)

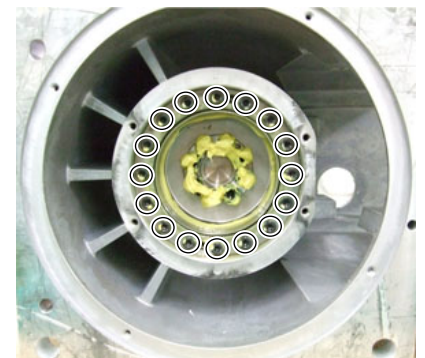

7. Apply grease to the inside of the flexspline.

Grease: SK-1A
Grease volume: 40 g

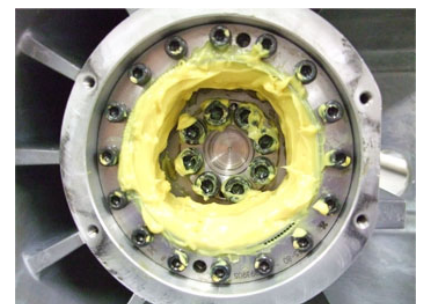

8. Apply grease to the bearing of the wave generator.

Grease: SK-1A



9. Install the wave generator to the shaft.

Hexagon socket head set screws: 2-M5×6
(with a brass bushing)

Tightening torque: 3.9 N·m (40 kgf·cm)

When installing the part, press the wave generator all the way in and fix the set screw to the D-cut face of the shaft. Insert the brass bushing to the end of the other set screw.



10. Install the bearing.

11. Install the assembled wave generator unit to the reduction gear unit.



12. Put the O-ring into the groove on the flange.

Carefully assemble the parts to avoid damaging the O-ring.
(Otherwise the grease may leak.)

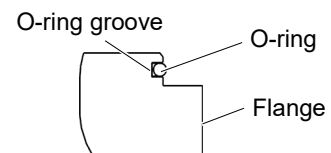
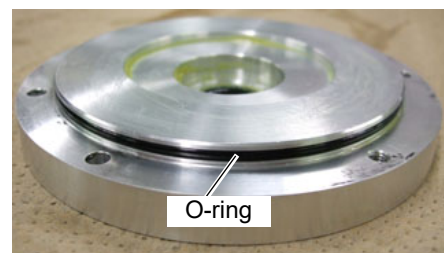

13. Install the flange to the base.

Hexagon socket head cap bolt: 4-M4×15

Tightening torque: 4.9 N·m (50 kgf·cm)

Carefully insert the shaft to the flange to avoid damaging the seal.

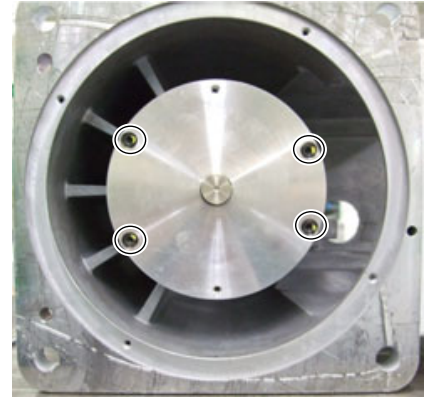

14. Install the pulley 2.

Hexagon socket head set screws: 2-M5×10

(with a brass bushing)

Tightening torque: 3.9 N·m (40 kgf·cm)

Align the end of the shaft with the side of the pulley.

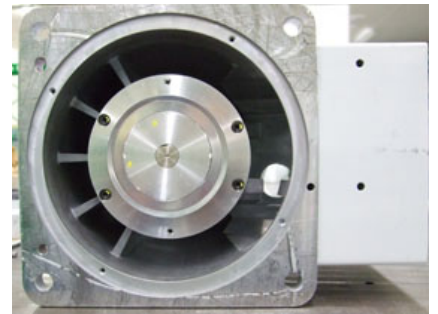

15. Loosely secure the Joint #1 motor unit.

Make sure that the motor unit can be moved by hand, and it does not tilt when being pulled. If the unit is secured too loose or too tight, the belt will not have proper tension.

16. Mount the Joint #1 motor unit

For details, refer to *Maintenance: 5.1 Joint #1 motor*, Installation step (6).

17. Mount the connector plate and the base bottom cover.

For details, refer to *Maintenance: 3. Covers*.

18. Calibrate the Joint #1.

For details, refer to *Maintenance: 16. Calibration*.

5.3 Joint #1 - Replacing the Timing Belt

	Name	Quantity	Note
Maintenance Part	Timing belt	Joint #1 C4-A601**	1 1520394
		Joint #1 C4-A901**	1 1593695
Tools	Hexagonal wrench (width across flats: 3 mm)	1	For M4 hexagon socket head cap bolt
	Torque wrench	1	
	Force gauge	1	For belt tension adjustment

Removal: Joint #1 Timing belt

1. Remove the Joint #1 motor unit.
For details, refer to *Maintenance: 5.1 Joint #1 motor*, Removal step (1) to (4).
2. Remove the Joint #1 timing belt.

Work process is common between C4-A601** and C4-A901**

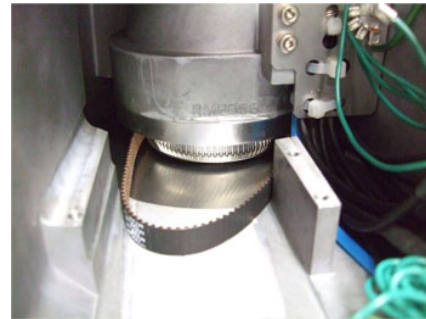

Installation: Joint #1 Timing belt

1. Place the Joint #1 timing belt around the Joint #1 pulley in the back in the photo.
2. Mount the Joint #1 motor unit.
For details, refer to *Maintenance: 5.1 Joint #1 motor*, Installation step (5) to (9).

5.4 Joint #1 - Replacing the Electromagnetic Brake

	Name	Quantity	Note	
Maintenance Parts	Joint #1 electromagnetic brake	1	1605914	
	Noise dissipative diode	1	2167709	
Tools	Hexagonal wrench	width across flats: 2.5 mm	1	For M5 hexagon socket head set screw
		width across flats: 3 mm	1	For M4 hexagon socket head cap bolt
	Torque wrench	1		
	Force gauge	1	For belt tension adjustment	

Removal: Joint #1 Electromagnetic brake

- Remove the Joint #1 electromagnetic brake from the Joint #1 motor unit.
For details, refer to *Maintenance: 5.1 Joint #1 motor*, Removal step (1) to (6).
- Remove the following connector.

Connector: D (for noise dissipative diode)



Installation: Joint #1 Electromagnetic brake

- Install the following connector to the connector of the electromagnetic brake.

Connector: D (for noise dissipative diode)



- Mount the Joint #1 motor unit.
For details, refer to *Maintenance: 5.1 Joint #1 motor*, Installation step (2) to (9).

6. Joint #2

 WARNING	<ul style="list-style-type: none"> ■ Do not connect or disconnect the motor connectors while the power to the robot system is turned ON. Connecting or disconnecting the motor connectors with the power ON is extremely hazardous and may result in serious bodily injury as the Manipulator may move abnormally, and also may result in electric shock and/or malfunction of the robot system. ■ To shut off power to the robot system, disconnect the power plug from the power source. Be sure to connect the AC power cable to a power receptacle. DO NOT connect it directly to a factory power source. ■ Before performing any replacement procedure, turn OFF the Controller and related equipment, and then disconnect the power plug from the power source. Performing any replacement procedure with the power ON is extremely hazardous and may result in electric shock and/or malfunction of the robot system.
--	---

 CAUTION	<ul style="list-style-type: none"> ■ Be careful not to apply excessive shock to the motor shaft during replacement. It may shorten the life of the motors and encoder and/or damage them. ■ Never disassemble the motor and the encoder. Disassembled motor and encoder will cause a positional gap and cannot be used again.
--	---

After parts have been replaced (motors, reduction gear units, timing belts, etc.), the Manipulator cannot perform positioning properly because a gap exists between the origin stored in each motor encoder and its corresponding origin stored in the Controller. Therefore, it is necessary to match these origins after replacing the parts. The process of aligning the two origins is called “Calibration”. Refer to *Maintenance 16. Calibration* and perform the calibration after the parts replacement.

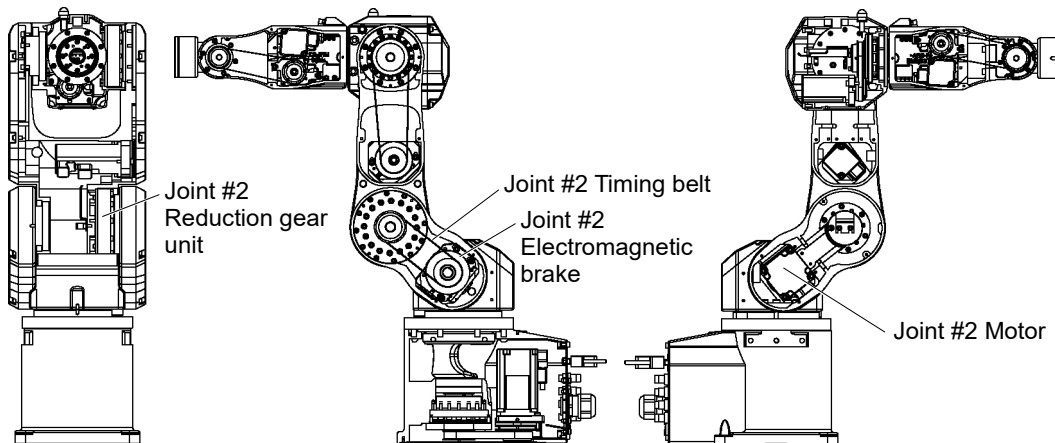

6.1 Joint #2 - Replacing the Motor

	Name		Quantity	Note
Maintenance Parts	AC servo motor 400 W		1	2150748
	Radiation Sheet		1	1549699
Tools	Hexagonal wrench	width across flats: 2.5 mm	1	For M5 hexagon socket set screw
		width across flats: 3 mm	1	For M4 hexagon socket head cap bolt
		width across flats: 4 mm	1	For M5 hexagon socket head cap bolt
	Cross-point screwdriver		1	For covers
	Torque wrench		1	
	Cloth		1	For pressing arms
Force gauge		1	For belt tension	

The brake is mounted on the Joint #2 to prevent the arm from lowering due to its own weight while the Controller power is OFF or the motor is OFF status. However, the brake does not work during replacement.

To replace the Joint #2 motor, tilt the Arm #2 and press it toward the Arm #1. (See the step (3))

When pressing the arm, put a cloth or a similar material between the arms to avoid each arm from contacting. This also protects the arm surfaces and coatings.

Removal: Joint #2 Motor

1. Remove the Arm #1 top cover and the Arm #1 side cover.
For details, refer to *Maintenance: 3. Covers*.
2. Turn ON the Controller power.
3. Tilt Arm #2.
Put a cloth between Arm #1 and Arm #2 so that two arms do not touch each other.

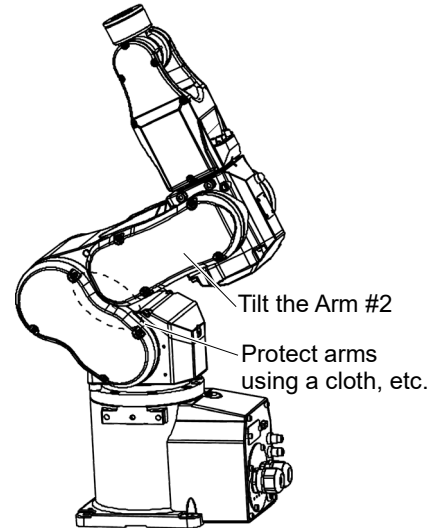

4. Turn OFF the Controller power.
5. Disconnect the following connectors.
Connector: X121, X021, X62, BR021
(Hold the clip to remove.)

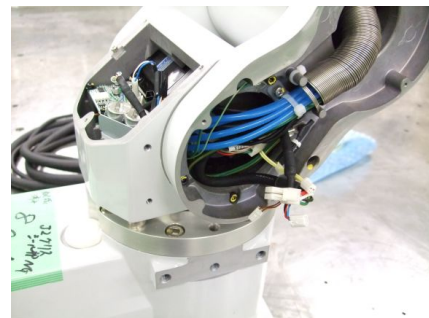

6. Tilt the Arm #2 and remove the Joint #2 motor unit and the belt from the Arm #1.

If the bolts are removed with the Arm #2 is not tilted, the belt will come off and the Arm #2 will fall. Be sure to tilt the Arm.

Hexagon socket head cap bolt: 3-M4×18 (with a plain washer)

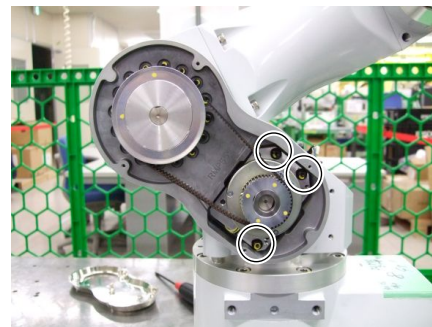

7. Remove the Joint #2 pulley 1 and the drive boss from the motor shaft of the Joint #2 motor unit.

Drive boss and the pulley

Hexagon socket set screws: 2-M5×6 (with a brass bushing)

Pulley and the motor shaft

Hexagon socket set screws: 2-M5×10 (with a brass bushing)



There is a brass bushing on one of the set screws fixing the driving boss and the pulley.
Be careful not to lose it.

8. Remove the Joint #2 electromagnetic brake.

Hexagon socket set screw: 1-M5×8

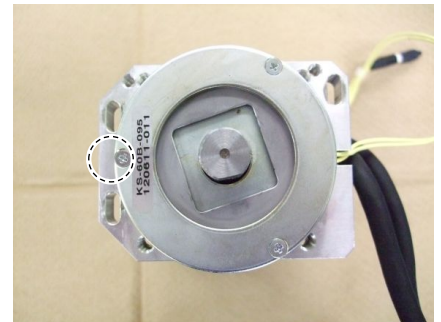

9. Remove the motor plate from the Joint #2 motor.

Hexagon socket head cap bolts: 4-M5×15



Installation: Joint #2 Motor

1. Install the motor plate to the Joint #2 motor.

Hexagon socket head cap bolts: 4-M5×15

Tightening torque: 9.8 N·m (100 kgf·cm)

Be careful of the direction of the motor plate. (See the photo.)

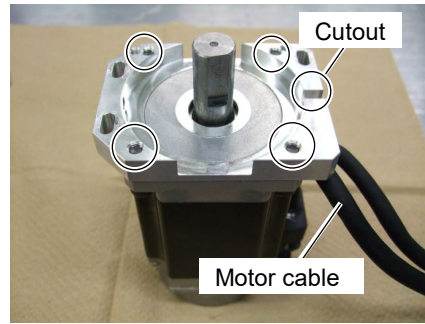

2. Mount the Joint #2 electromagnetic brake to the Joint #2 motor unit.

Align the position of the brake wire with the groove on the motor plate. Then, set the flat surface of the brake to the set screw side and secure the brake. Be careful not to cut the brake wire by getting it caught between the brake and the motor plate.

Press the brake toward the motor plate and tighten the set screw.

Hexagon socket set screw: 1-M5×8

Tightening torque: 3.9 N·m (40 kgf·cm)



3. Mount the drive boss and the pulley 1 to the Joint #2 motor unit.

Put the end faces of the brake boss and the pulley 1 together and fix them.

Hexagon socket set screws: 2-M5×6 (with a brass bushing)

Tightening torque: 3.9 N·m (40 kgf·cm)

Set the pulley 1 and the motor shaft.

Leave 0.5 mm for the electromagnetic brake.

Hexagon socket set screw: 2-M5×10 (with a brass bushing)

Tightening torque: 3.9 N·m (40 kgf·cm)

Fix the parts so that the end of the motor shaft and the surface of the pulley become flat.

See the photo for positions of the set screws.

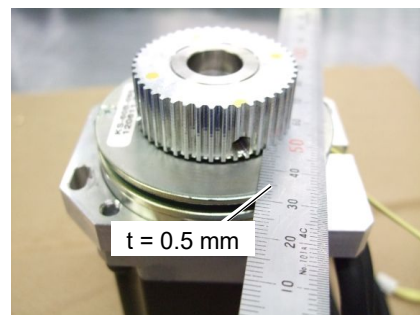
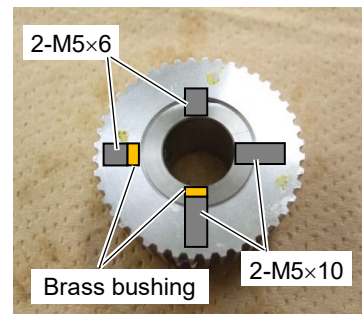

4. Attach the Radiation sheet to the Joint #2 motor.

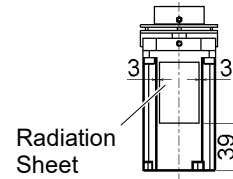

5. Put the Joint #2 motor unit in the Arm #1.
Place the timing belt around the pulley 1 and the pulley 2.
Check that the teeth of the timing belt engage with these of the pulley.
When securing the motor unit temporarily, make sure that the motor unit can be moved by hand, and it does not tilt when being pulled. If the unit is secured too loose or too tight, the belt will not have proper tension.



6. Apply tension to the Joint #2 motor unit and fix it.
Install the screw for tension adjustment to the motor plate.

Screw: M4×30 or longer (recommended length)

Pass a suitable cord or a string (insulation lock) to the screw. Pull the cord using a force gauge or a similar tool to apply specified tension.

Joint #2 timing belt tension = $78.4 \text{ N} \pm 9.8 \text{ N}$ (8 kgf \pm 1 kgf)

Apply tension by pressing toward the “A” surface in the figure and secure the motor unit.

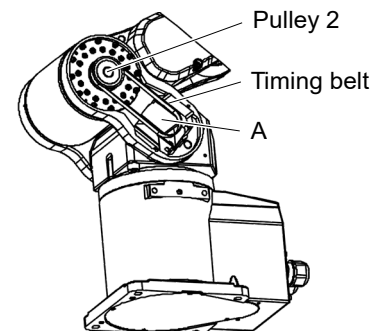

Hexagon socket head cap bolt: 3-M4×18 (with a plain washer)

Tightening torque: 4.9 N·m (50 kgf·cm)

Make sure to remove the screw for tension adjustment.



7. Connect the following connectors.
Connectors: X121, X021, X62, BR021
8. Mount the Arm #1 cover and the Arm #1 side cover.
For details, refer to *Maintenance: 3. Covers*.
9. Perform the calibration.
For details, refer to *Maintenance: 16. Calibration*.

6.2 Joint #2- Replacing the Reduction Gear Unit

A reduction gear unit consists of the following three parts. Also, two additional parts are included as accessories. When replacing the reduction gear unit, be sure to replace these parts all together as a set.

Reduction gear unit: Wave generator, Flexspline (CRB combined), Circular spline

Accessory: O-ring×2

For details, refer to *Maintenance: 17. Maintenance Parts List*.

It is recommended replacing the O-ring (for Joint #2) when replacing the reduction gear unit.

	Name		Quantity	Note
Maintenance Parts	Joint #2 reduction gear unit		1	1687023
	Joint #2 O-ring		1	1510528
Tools	Hexagonal wrench	width across flats: 2.5 mm	1	For M3 hexagon socket head cap bolt For M5 hexagon socket set screw
		width across flats: 3 mm	1	For M4 hexagon socket head cap bolt
	Cross-point screwdriver		1	For covers
	Torque wrench		1	
	Spatula		1	For applying grease
	Force gauge		1	For belt tension
	Wiping cloth		2	For wiping grease

Removal: Joint #2 Reduction gear unit

1. Remove the following covers.

For details, refer to *Maintenance: 3. Covers*.

Arm #1 top cover
 Arm #1 side cover
 Arm #2 side cover
 Arm #3 head cover
 User plate

When removing the user plate, remove the following parts as well.

D-sub 9-pin connector
 4 air tubes

2. Remove the Joint #2 timing belt.

For details, refer to *Maintenance: 6.3 Joint #2 – Replacing the Motor*, Removal steps (1) through (4).

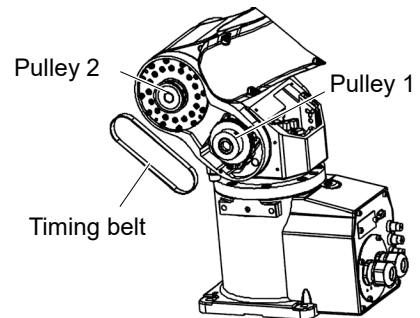

3. Remove the cable unit.

For details, refer to *Maintenance: 4.1 Replacing the Cable Unit*, removal steps (9) through (26).

4. Pull out the cables from the Arm #1.

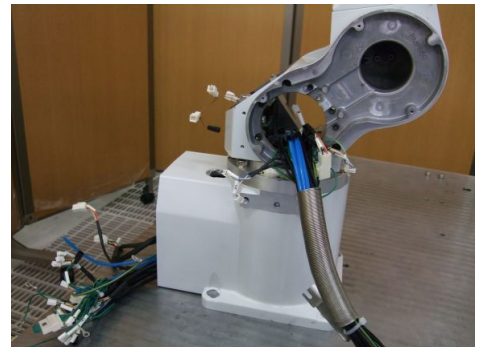

5. Turn the Manipulator laterally with the motor pulley facing down



- When turning the Manipulator laterally, there must be two or more people to work on it so that at least one of them can support the arm while the other is removing the bolts.
 Removing the bolts without supporting the system may result in the arm falling, bodily injury, and/or malfunction of the robot system.

6. Remove the Arm #1 plate.

Hexagon socket head cap bolt: 6-M4×12

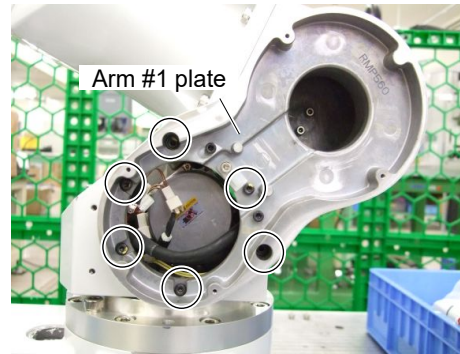

7. Turn the Manipulator to the opposite side and remove the pulley 2.

Hexagon socket set screws: 2-M5×10 (with a brass bushing)

There is a brass bushing in one of the set screws.
Be careful not to lose it.

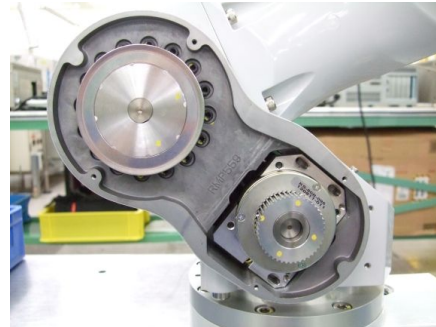

8. Remove the screws securing the reduction gear unit.

Hexagon socket head cap bolts: 16-M4×30

By removing the screws, the Arm #2, #3, #4, #5, and #6 (end effector) can be separated.

Have at least two workers so that one can support the Manipulator while the other worker is removing the bolts.

Wipe grease on the parts while removing them.



9. Remove the wave generator from the reduction gear unit.

If the wave generator unit does not come off easily, set the pulley 2 as shown in the photo to the shaft and pull out the parts.

Remove the wave washer on the Arm #2 hole. The wave washer will be used again. Be careful not to lose it.

Wipe grease on the parts while removing them.



10. Remove the wave generator from the shaft.

Hexagon socket set screws: 2-M5×6 (with a brass bushing)

Remove the bearing. The bearing will be used again.
Be careful not to lose it

There is a brass bushing on one of the set screws.
Be careful not to lose it.

Wipe grease on the parts while removing them.

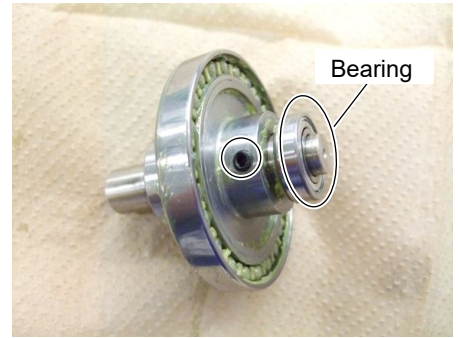

11. Remove the reduction gear unit from the Arm #2.

Hexagon socket head cap bolt: 12-M4×30

Wipe grease on the parts while removing them.



12. Remove the O-ring.

Wipe grease on the parts while removing them.





13. Wipe grease using a cloth or a similar material if it is attached to the Arm #1, and #2, etc.

Installation: Joint #2 Reduction gear unit

1. Unpack the new reduction gear unit package and check if it contains the parts on the right.

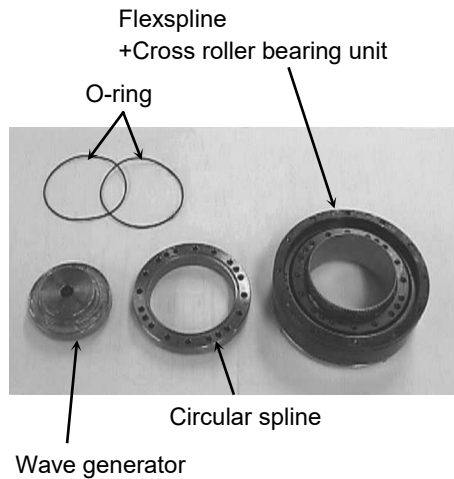
Tooth grooves of the circular spline and the flexspline, and the bearing of the wave generator are pre-greased. Wipe grease if it is attached to the fitting parts.



 CAUTION	<ul style="list-style-type: none"> Do not adjust the bolts securing the flexspline and the cross roller bearing. If the bolts are adjusted, it requires centering of the parts by the reduction gear unit manufacturer.
---	--

2. Set the O-rings to the grooves on both faces of the circular spline. Make sure to fit the rings completely.

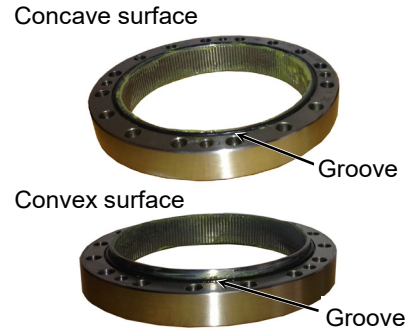
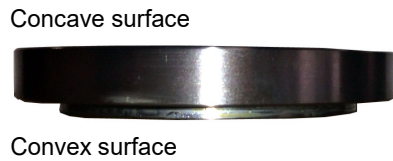

3. Set the flexspline with the convex surface facing down. After setting it, make sure to confirm that the surfaces of the circular spline and flexspline are matched.

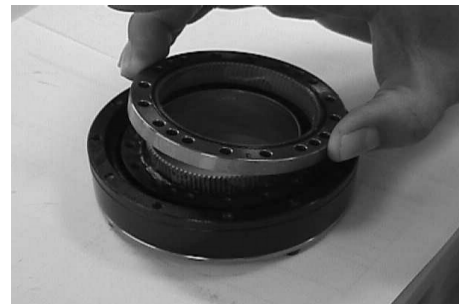

4. Match the screw holes on the cross roller bearing's inner ring and the drilled holes on the circular spline.



5. Fix the cross roller bearing's inner ring and the circular spline.

Hexagon socket head cap bolts: 4-M3×15

Tightening torque: 2.5 N·m (25 kgf·cm)



6. Grease the bearing of the wave generator and install the wave generator to the shaft.

Hexagon socket set screw: 2-M5×6 (with a brass bushing)

Tightening torque: 3.9 N·m (40 kgf·cm)

When installing the wave generator, push it to the end and set the set screws on the shaft's flat face.

For the other set screw, set the brass bushing to the end.

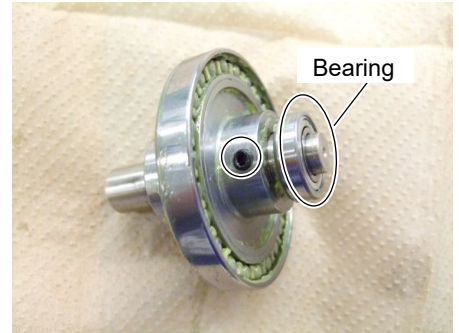

7. Install the removed bearing to the shaft.

8. Set the O-ring to the groove on the installation face of the Arm #2 reduction gear unit.



9. Install the reduction gear unit.

Hexagon socket head cap bolt: 12-M4×30

Tightening torque: 4.9 N·m (50 kgf·cm)

Installation face of the Arm #2 reduction gear unit has clearance holes.

Install the reduction gear unit to match the screws and the clearance holes.

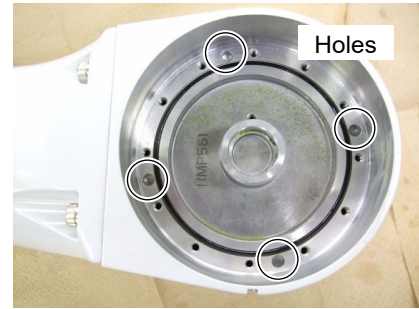
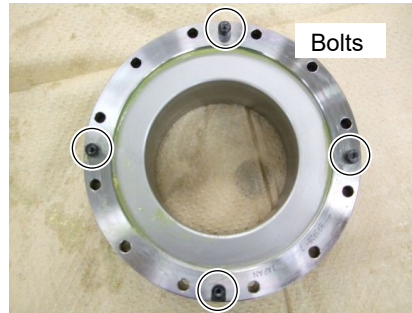
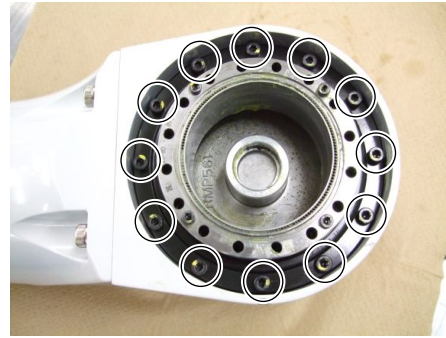

10. Grease the inner side of the flexspline.

Grease: SK-1A

Grease amount: 30 g



11. Set the wave washer to the position where the Arm #2 bearing will be set.

12. Insert the wave generator to the reduction gear unit and fix it.

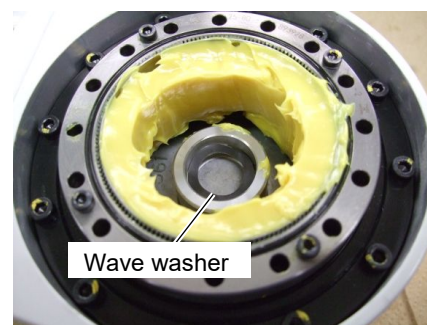

13. Install the Arm #2 and the reduction gear unit to the Arm #1.

Hexagon socket head cap bolt: 16-M4×30

Tightening torque: 4.9 N·m (50 kgf·cm)

Make sure to install after matching the screw hole positions. Match the positions of screws (reduction gear unit×4, arm×1) and clearance holes.

When installing the shaft to the hole of the Arm #1, be careful not to damage the seal.

Be careful not to let the O-ring on the groove of the circular spline comes off.

14. Install the pulley 2.

Hexagon socket set screws: 2-M5×10 (with a brass bushing)

Tightening torque: 3.9 N·m (40 kgf·cm)

Join the end of the shaft and the side of the pulley, and then fix them.

15. Turn the Arm to the opposite side and install the Arm #1 plate.

Hexagon socket head cap bolts: 6-M4×12

Tightening torque: 4.9 N·m (50 kgf·cm)

After installing the plate, move the arm to make sure that there is no errors.

16. Install the cable unit.

For details, refer to *Maintenance: 4.1 Replacing the Cable Unit*, installation steps (7) through (43) and (62) through (64).

17. Place the Joint #2 timing belt to the pulley 1 and the pulley 2 of the Joint #2.

18. Apply tension to the Joint #2 motor unit and fix it.

For details, refer to *Maintenance: 6.1 Joint #2 – Replacing the Motor*, Installation steps (10) through (13).

19. Install the removed covers.

For details, refer to *Maintenance: 3. Covers*.

20. Perform the calibration.

For details, refer to *Maintenance: 16. Calibration*.

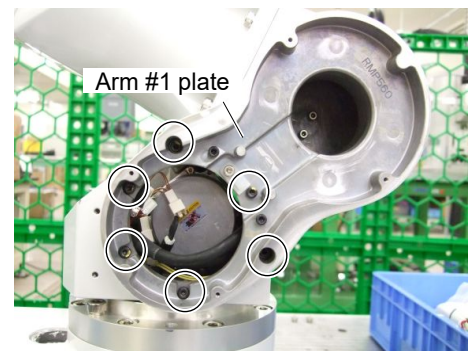

6.3 Joint #2 - Replacing the Timing Belt

	Name		Quantity	Note
Maintenance Parts	Timing belt	Joint #2 of C4-A601**	1	1520354
		Joint #2 of C4-A901**	1	1593696
Tools	Hexagonal wrench (width across flats: 3 mm)		1	For M4 hexagon socket head cap bolt
	Cross-point screwdriver		1	For covers
	Torque wrench		1	
	Cloth		1	For pressing arms
	Force gauge		1	For belt tension

Removal: Joint #2 Timing belt

- Follow Removal steps (2) through (4) of *Maintenance: 6.1 Joint #2 – Replacing the Motor*.
- Remove the Arm #1 side cover.
For details, refer to *Maintenance: 3. Covers*.
- Loosen the Joint #2 motor unit set screw.
Hexagon socket head cap bolts: 3-M4×18
(with a plain washer)
- Remove the Joint #2 timing belt.
Remove the timing belt from the pulley 1 first.
Then, remove the timing belt from the pulley 2.



This procedure is common in C4-A601** and C4-A901**.

Installation: Joint #2 Timing belt

- Place the Joint #2 timing belt to the pulley 1 and the pulley 2 of the Joint #2.
Place the timing belt to the pulley 2 first. Then, place the timing belt to the pulley 1.
- Secure the Joint #2 motor unit.
For details, refer to *Maintenance: 6.1 Joint #2 – Replacing the Motor*, Installation steps (6), (8), and (9).

6.4 Joint #2 - Replacing the Electromagnetic Brake

	Name		Quantity	Note
Maintenance Parts	Joint #2 electromagnetic brake		1	1605914
	Noise dissipative diode		1	2167709
Tools	Hexagonal wrench	width across flats: 2.5 mm	1	For M5 hexagon socket set screw
		width across flats: 3 mm	1	For M4 hexagon socket head cap bolt
	Cross-point screwdriver		1	For covers
	Torque wrench		1	
	Cloth		1	For pressing arms
	Force gauge		1	For belt tension

Removal: Joint #2 Electromagnetic brake

- Remove the Joint #2 electromagnetic brake.
For details, refer to *Maintenance: 6.1 Joint #2 – Replacing the Motor*, Installation steps (1) through (8).
- Disconnect the following connectors.
Connector: D (for noise dissipative diode)

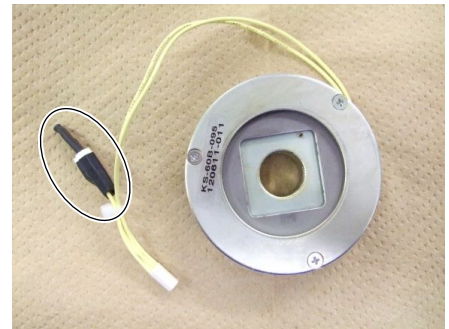



Installation: Joint #2 Electromagnetic brake

- Connect the following connector to the electromagnetic brake connector.
Connector: D (for noise dissipative diode)
- Assemble the Joint #2 electromagnetic brake and mount the motor unit.
For details, refer to *Maintenance: 6.1 Joint #2 – Replacing the Motor*, Installation steps (2) through (9).



7. Joint #3

 WARNING	<ul style="list-style-type: none"> ■ Do not connect or disconnect the motor connectors while the power to the robot system is turned ON. Connecting or disconnecting the motor connectors with the power ON is extremely hazardous and may result in serious bodily injury as the Manipulator may move abnormally, and also may result in electric shock and/or malfunction of the robot system. ■ To shut off power to the robot system, disconnect the power plug from the power source. Be sure to connect the AC power cable to a power receptacle. DO NOT connect it directly to a factory power source. ■ Before performing any replacement procedure, turn OFF the Controller and related equipment, and then disconnect the power plug from the power source. Performing any replacement procedure with the power ON is extremely hazardous and may result in electric shock and/or malfunction of the robot system.
--	---

 CAUTION	<ul style="list-style-type: none"> ■ Be careful not to apply excessive shock to the motor shaft during replacement. The shock may shorten the life of the motors and encoder and/or damage them. ■ Never disassemble the motor and the encoder. Disassembled motor and encoder will cause a positional gap and cannot be used again.
--	--

After parts have been replaced (motors, reduction gear units, electromagnetic brakes, timing belts, etc.), the Manipulator cannot perform positioning properly because a gap exists between the origin stored in each motor encoder and its corresponding origin stored in the Controller.

Therefore, it is necessary to match these origins after replacing the parts.

The process of aligning the two origins is called “Calibration”.

Refer to *Maintenance 16. Calibration* and perform the calibration after the parts replacement.

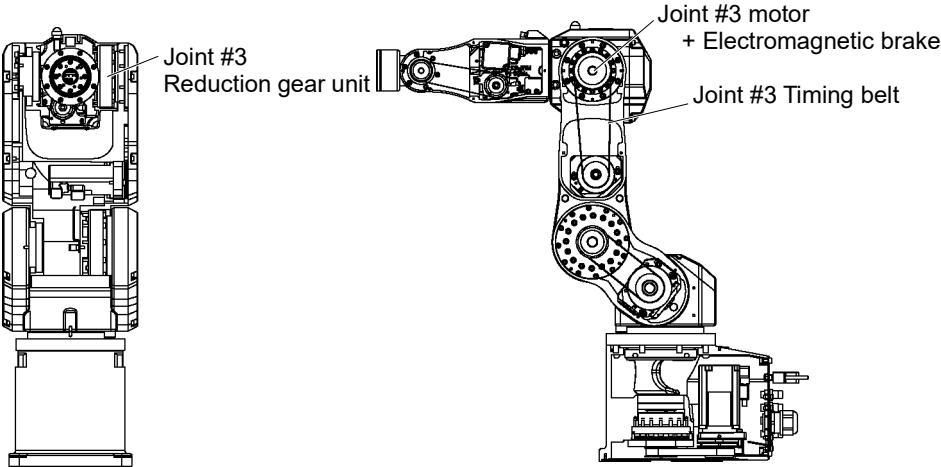

7.1 Joint #3 - Replacing the Motor (with a Brake)

	Name		Quantity	Note
Maintenance Parts	AC servo motor 150 W (with a brake)		1	2209414
	Noise dissipative diode		1	2167709
Tools	Hexagonal wrench	width across flats: 2 mm	1	For M4 hexagon socket set screws
		width across flats: 3 mm	1	For M4 hexagon socket head cap bolts
	Cross-point screwdriver		1	For covers
	Torque wrench		1	
	Cloth		1	For pressing arms
	Force gauge		1	For belt tension adjustment
	Nipper		1	

The brake is mounted on the Joint #3 to prevent the arm from lowering due to its own weight while the Controller power is OFF or the motor is OFF status. However, the brake does not work during replacement.

To replace the Joint #3 motor (with a brake), tilt the Arm #3 and press it toward the Arm #2. (See the step (2).)

When pressing the arm, put a cloth or a similar material between the arms to avoid them from contacting. This also protects the arm surfaces and coatings.

Removal: Joint #3 Motor (with a brake)

1. Turn ON the Controller power.
2. Tilt the Arm #3.
Put a cloth between the Arm #2 and the Arm #3 so that two arms do not touch each other.

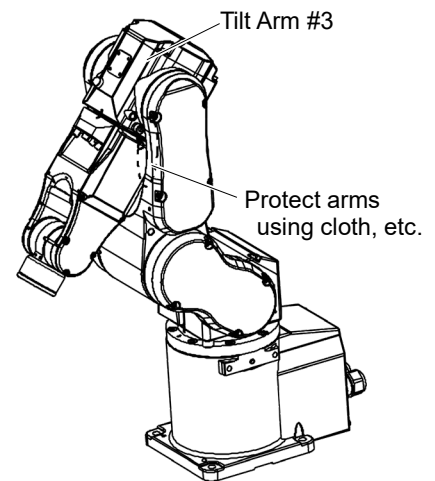

3. Turn OFF the Controller power.
4. Remove the Arm #2 side cover.
For details, refer to *Maintenance: 3. Covers*.

5. Disconnect the following connectors.

Connector: X131, X031, BT3, BR031

(Hold the clip to remove.)

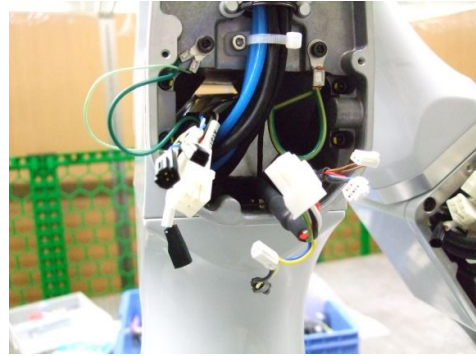

6. Remove the Joint #3 motor unit and the belt from the Arm #2.

Hexagon socket head cap bolts: 2-M4×15

(with a plain washer)

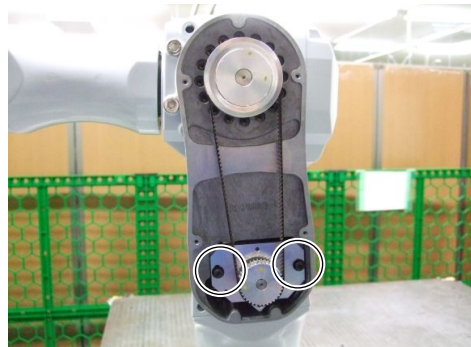

7. Remove the connector for the noise dissipative diode.

Connector: D

The noise dissipative diode will be used again.

Be careful not to lose it.

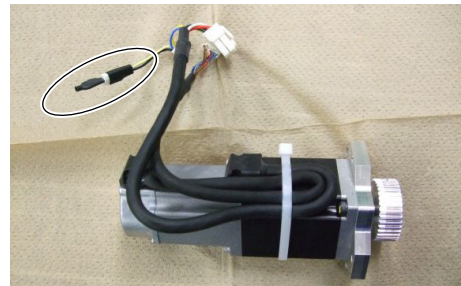

8. Remove the Joint #3 pulley 1 from the Joint #3 motor unit.

Hexagon socket set screws: 2-M4×8 (with a brass bushing)

There is a brass bushing in one of the set screw fixing the drive boss and the pulley. Be careful not to lose it.

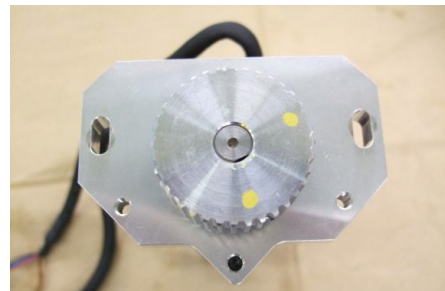

9. Remove the motor plate from the Joint #3 motor.

Hexagon socket head cap bolt: 2-M4×12

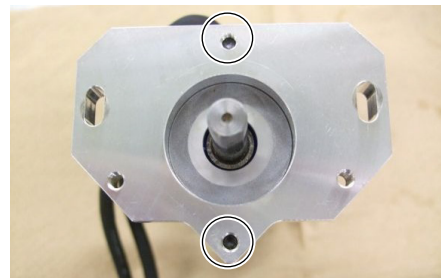

Installation: Joint #3 Motor (with a brake)

1. Install the motor plate to the Joint #3 motor.
Be careful of the direction of the motor plate. Be sure to tilt the Arm. (See the figure.)

Hexagon socket head cap bolt: 2-M4×12

Tightening torque: 4.9 N·m (50 kgf·cm)

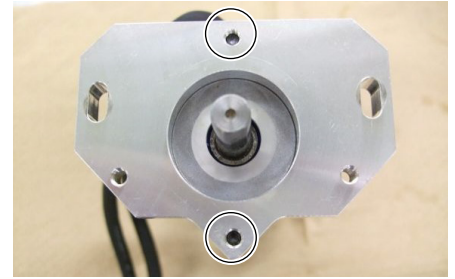

2. Mount the pulley 1 to the Joint #3 motor unit.

Hexagon socket set screw: 2-M4×8 (with a brass bushing)

Tightening torque: 2.5 N·m (25 kgf·cm)

Set the set screw to the flat face of the motor shaft. For the other set screw, set the brass bushing to the end. Join the end of the motor shaft and the side of the pulley, and then fix them.

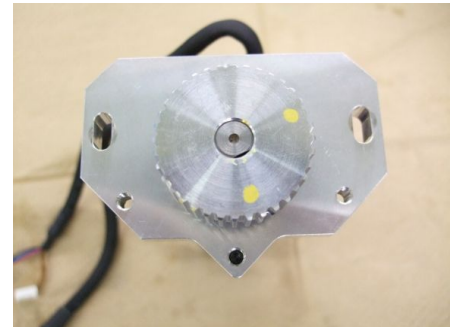

3. Fix the motor cable to the motor.

Wire tie: AB200

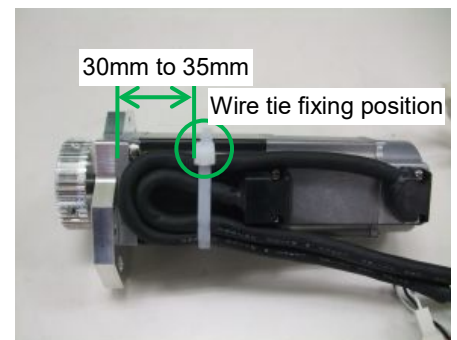

4. Install the removed noise dissipative diode.

Connector: D

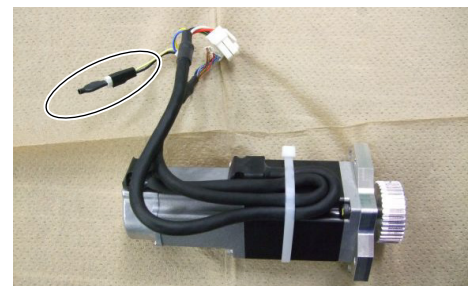

5. Install the motor unit to the Arm #2.

Hexagon socket head cap bolts: 2-M4×15
(with a plain washer)

Temporarily tighten the screws.

Tighten the screws loosely enough to hold the motor unit.



6. Place the Joint #3 timing belt around the pulley 1 and 2 and secure temporarily.

Check that the teeth of the timing belt engage with these of the pulley.

When securing the motor unit temporarily, make sure that the motor unit can be moved by hand, and it does not tilt when being pulled. If the unit is secured too loose or too tight, the belt will not have proper tension.

Make sure that the clearance of the both motor units is the same.

7. Apply tension to the Joint #3 motor unit and fix it.

Install the screw for tension adjustment to the motor plate.

Screw: M4×40 or longer (recommended length)

Pass a suitable cord or a string (insulation lock) to the screw. Pull the cord using a force gauge or a similar tool to apply specified tension.

Joint #3 timing belt tension = $68.6 \text{ N} \pm 9.8 \text{ N}$ (7 kgf \pm 1 kgf)

Secure the Joint #3 motor unit by applying tension.

Hexagon socket head cap bolt: 2-M4×15 (with a plain washer)

Tightening torque: 4.9 N·m (50 kgf·cm)

Make sure to remove the screw for tension adjustment.

8. Connect the following connectors.

Connector: X131, X031, BT3, BR021

9. Install the Arm #2 side cover.

For details, refer to *Maintenance: 3. Covers*.

10. Perform the calibration.

For details, refer to *Maintenance: 16. Calibration*.

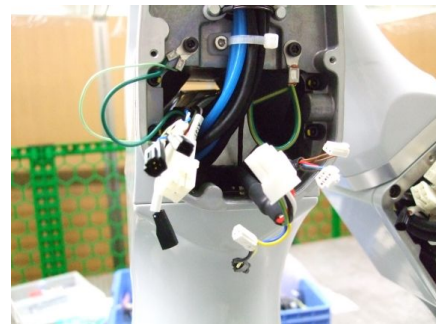
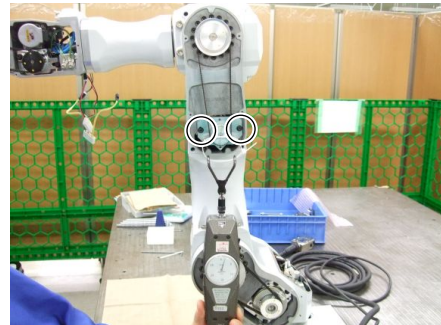
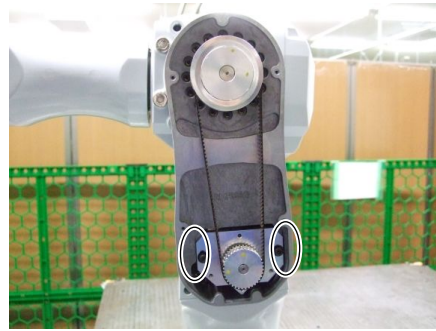

7.2 Joint #3 - Replacing the Reduction Gear Unit

A reduction gear unit consists of the following three parts. Also, two additional parts are included as accessories. When replacing the reduction gear unit, be sure to replace these parts all together as a set.

Reduction gear unit: Wave generator, Flexspline (CRB combined), Circular spline

Accessory: O-ring × 2

For details, refer to *Maintenance: 17. Maintenance Parts List*.

It is recommended replacing the O-rings (for Joint #3) when replacing the reduction gear unit.

	Name	Quantity	Note	
Maintenance Parts	Joint #3 reduction gear unit	1	1593859	
	Joint #3 O-ring	1	1520370	
Tools	Hexagonal wrench	width across flats: 2 mm	1	For M4 hexagon socket set screws
		width across flats: 2.5 mm	1	For M3 hexagon socket head cap bolts
		width across flats: 3 mm	1	For M4 hexagon socket head cap bolts
	Cross-point screwdriver	1	For covers	
	Torque wrench	1		
	Spatula	1	For applying grease	
	Force gauge	1	For belt tension adjustment	
	Wiping cloth	2	For wiping grease	

Removal: Joint #3 Reduction gear unit

1. Remove the following parts.

Arm #2 side cover

Arm #3 head cover

Arm #4 side cover

User plate

When removing the user plate, remove the following parts from the plate.

D-sub 9-pin connector

4 air tubes

For details, refer to *Maintenance: 3. Covers*.

2. Remove the Joint #3 timing belt.

For details, refer to *Maintenance: 7.3 Joint #3 –*

Replacing the Motor, Removal steps (1) through (3).

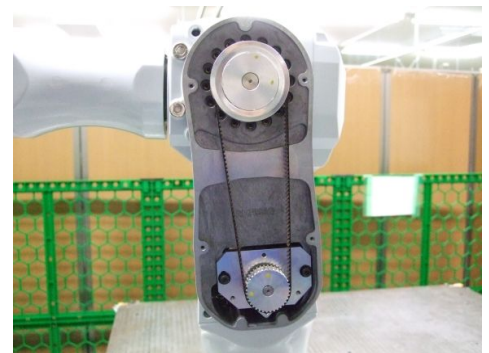

3. Remove the cable unit.

For details, refer to *Maintenance: 4.1 Replacing the Cable Unit*, steps (9) through (21).

4. Remove the Arm #2 plate.

Hexagon socket head cap bolts: 5-M4×12

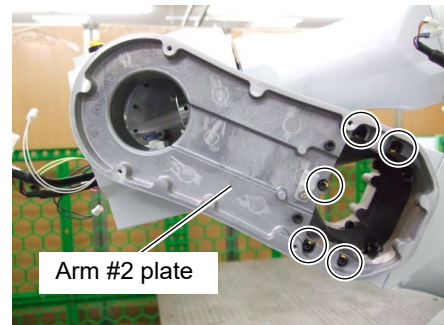

5. Remove the pulley 2.

Hexagon socket set screws: 2-M4×8
(with a brass bushing)

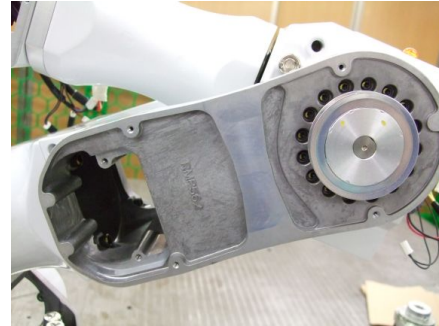

6. Remove the screws securing the reduction gear unit.

Hexagon socket head cap bolts: 16-M3×20

By removing the screws, Arm #3, #4, #5, and #6 (end effector) can be separated.

Have at least two workers so that one can support the Manipulator while the other worker is removing the screws.

The parts are greased. Wipe grease while removing the parts.



7. Remove the wave generator from the reduction gear unit.

If the wave generator unit does not come off easily, set the pulley 2 to the shaft, as shown in the photo, and pull out the parts.

Remove the wave washer on the Arm #2 hole.

The wave washer will be used again. Be careful not to lose it.

The parts are greased. Wipe grease while removing the parts.

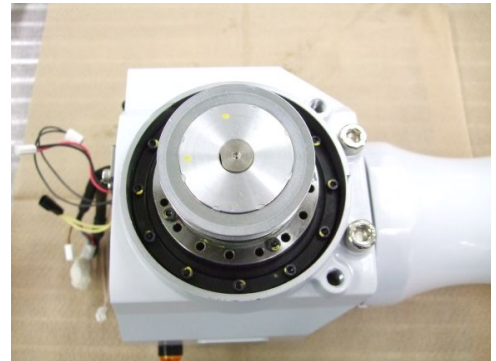
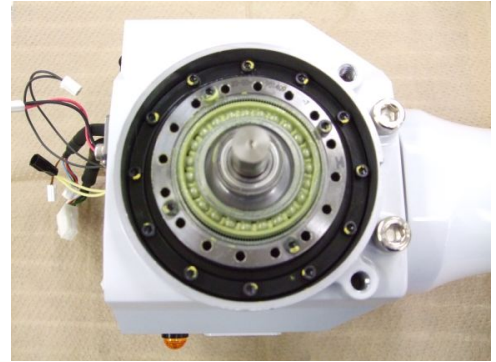

8. Remove the wave generator from the shaft.

Hexagon socket set screws: 2-M4×5
(with a brass bushing)

Remove the bearing. The bearing will be used again. Be careful not to lose it.

There is a brass bushing on one of the set screws. Be careful not to lose it.

The parts are greased. Wipe grease while removing the parts.



9. Remove the reduction gear unit from the Arm #3.

Hexagon socket set screws: 12-M3×26

The parts are greased. Wipe grease while removing the parts.

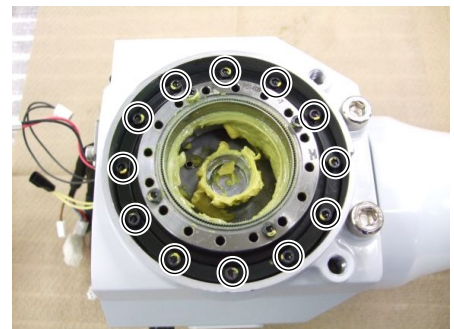

10. Remove the O-ring.

The parts are greased. Wipe grease while removing the parts.

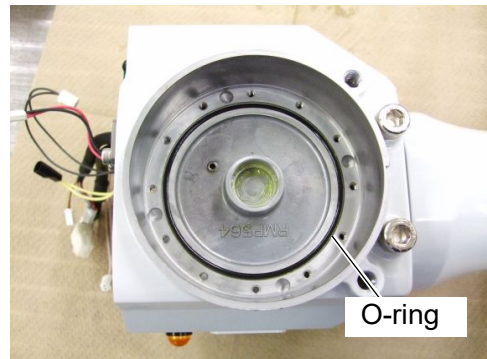



11. Wipe grease using a cloth or a similar material if it is attached to the Arm #2, and #3, etc.

Installation: Joint #3 Reduction gear unit

1. Unpack the new reduction gear unit package and check if it contains the parts on the right.

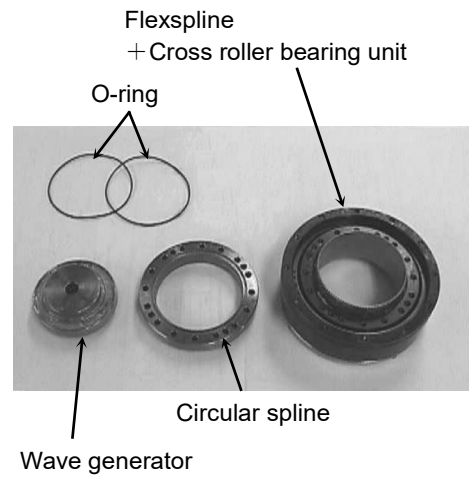
Tooth grooves of the circular spline and the flexspline, and the bearing of the wave generator are pre-greased. Wipe grease if it is attached to the fitting parts.



 CAUTION	<ul style="list-style-type: none"> ■ Do not adjust the bolts securing the flexspline and the cross roller bearing. If the bolts are adjusted, it requires centering of the parts by the reduction gear unit manufacturer.
---	--

2. Set the O-rings to the grooves on the both faces of the circular spline.
Make sure to fit the rings completely.

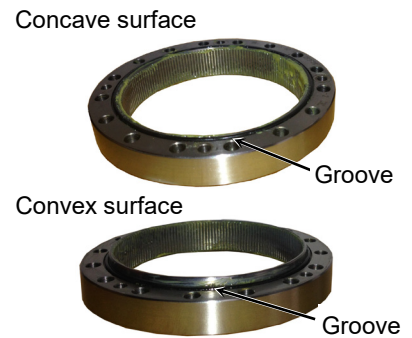
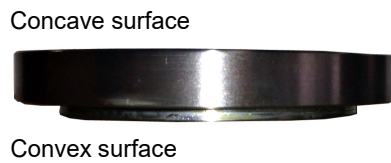

3. Set the flexspline with the convex surface facing down.



4. Match the screw holes on the cross roller bearing's inner ring and the drilled holes on the circular spline.



5. Fix the cross roller bearing's inner ring and the circular spline.

Hexagon socket head cap bolts: 4-M3×12

Tightening torque: 2.5 N·m (25 kgf·cm)



6. Grease the bearing of the wave generator and install it to the shaft.

Hexagon socket set screws: 2-M4×5 (with a brass bushing)

Tightening torque: 2.5 N·m (25 kgf·cm)

When installing the wave generator, push it to the end and set the set screws on the shaft's flat face.

For the other set screw, set the brass bushing to the end.



7. Install the removed bearing to the shaft.

8. Set the O-ring to the O-ring groove on the installation face of the Arm #3 reduction gear unit.

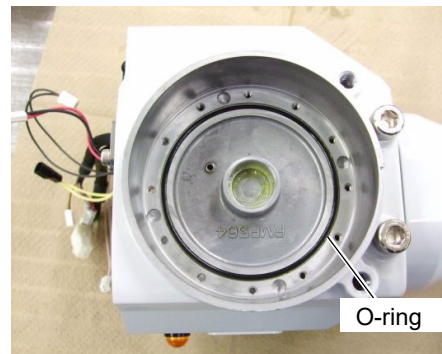

9. Install the reduction gear unit.

Hexagon socket head cap bolts: 12-M3×26

Tightening torque: 2.5 N·m (25 kgf·cm)

Installation face of the Arm #3 reduction gear unit has clearance holes.

Install the reduction gear unit to match the screws and the clearance holes.

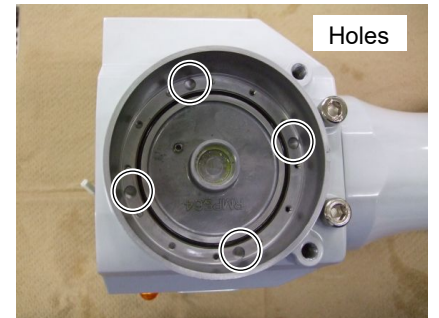
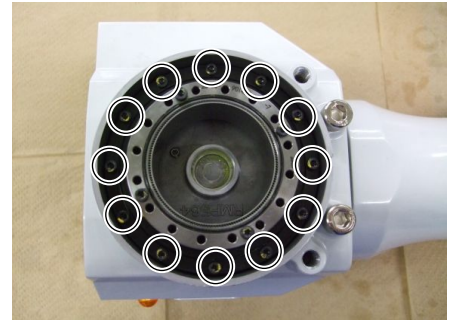
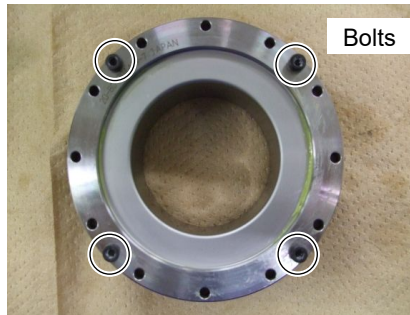

10. Grease the inner side of the flexspline.

Grease: SK-1A

Grease amount: 20 g

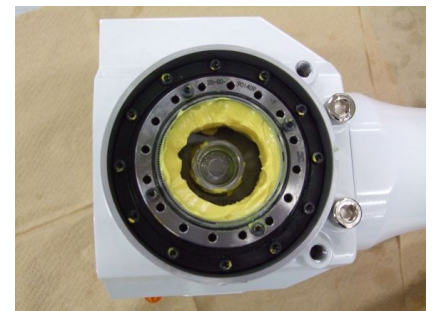

11. Set the wave washer to the position where the Arm #3 bearing will be set.

12. Insert the wave generator to the reduction gear unit and fix it.

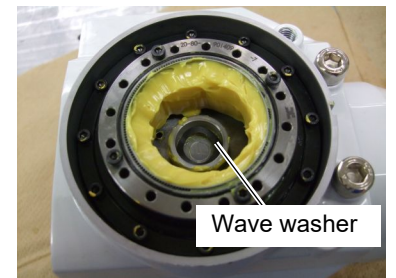

13. Install the assembled Arm #3 to the Arm #2.

Hexagon socket head cap bolts: 16-M3×20

Tightening torque: 2.5 N·m (25 kgf·cm)

When installing the shaft to the hole of the Arm #2, be careful not to damage the seal.

Be careful not to let the O-ring on the groove of the circular spline comes off.

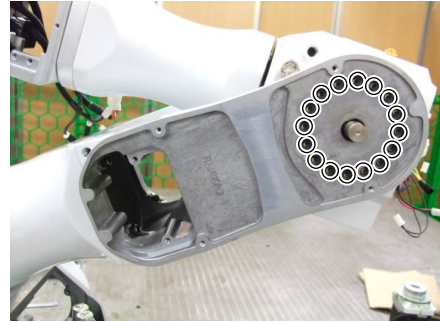

14. Install the pulley 2.

Hexagon socket set screws: 2-M4×8 (with a brass bushing)

Tightening torque: 2.5 N·m (25 kgf·cm)

Join the end of the shaft and the side of the pulley, and then fix them.

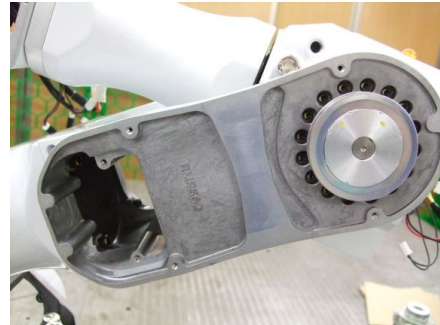

15. Install the Arm #2 plate.

Hexagon socket head cap bolts: 5-M4×12

Tightening torque: 4.9 N·m (50 kgf·cm)

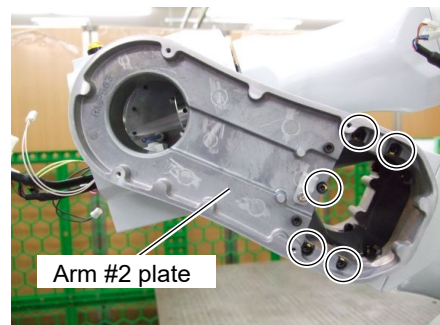

16. Install the cable unit.

For details, refer to *Maintenance: 4.1 Replacing the Cable Unit*, Installation steps (5) through (39) and through (62) to (63).

17. Place the Joint #3 timing belt to the pulley 1 and the pulley 2 of the Joint #3.

18. Secure the Joint #3 motor unit by applying tension.

For details, refer to *Maintenance: 7.1 Joint #3 – Replacing the Motor (with a Brake)*, Installation steps (8) through (11).

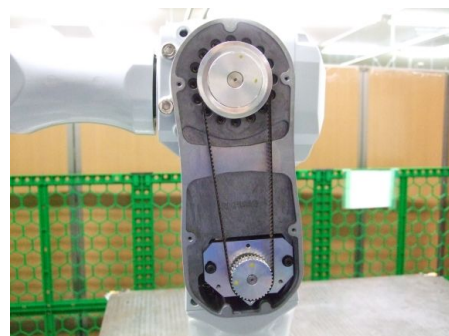

19. Install the removed covers.

For details, refer to *Maintenance: 3. Covers*.

20. Perform the calibration.

For details, refer to *Maintenance: 16. Calibration*.

7.3 Joint #3 - Replacing the Timing Belt

	Name		Quantity	Note
Maintenance Parts	Timing belt	Joint #3 of C4-A601**	1	1593697
		Joint #3 of C4-A901**	1	1593698
Tools	Hexagonal wrench (width across flats: 3 mm)		1	For M4 hexagon socket head cap bolt
	Cross-point screwdriver		1	For covers
	Torque wrench		1	
	Cloth		1	For pressing arms
	Force gauge		1	For belt tension

Removal: Joint #3 Timing belt

- Follow Removal steps (1) through (4) of *Maintenance: 7.1 Joint #3 – Replacing the Motor (with a Brake)*.
- Loosen the Joint #3 motor unit set screw.
Hexagon socket head cap bolts: 2-M4×15
- Remove the Joint #3 timing belt.
Remove the timing belt from the pulley 1 first.
Then, remove the timing belt from the pulley 2.

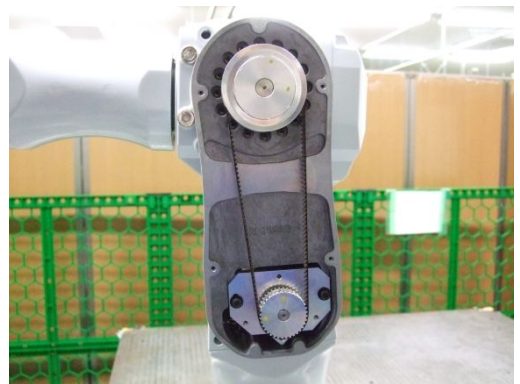

Installation: Joint #3 Timing belt

- Place the Joint #3 timing belt to the pulley 1 and the pulley 2 of the Joint #3.
Place the timing belt to the pulley 2 first. Then, place the timing belt to the pulley 1.
- Secure the Joint #3 motor unit.
For details, refer to *Maintenance: 7.1 Joint #3 – Replacing the Motor (with a Brake)*, Installation steps (6), (8), and (9).

8. Joint #4

 <p>WARNING</p>	<ul style="list-style-type: none">■ Do not connect or disconnect the motor connectors while the power to the robot system is turned ON. Connecting or disconnecting the motor connectors with the power ON is extremely hazardous and may result in serious bodily injury as the Manipulator may move abnormally, and also may result in electric shock and/or malfunction of the robot system.■ To shut off power to the robot system, disconnect the power plug from the power source. Be sure to connect the AC power cable to a power receptacle. DO NOT connect it directly to a factory power source.■ Before performing any replacement procedure, turn OFF the Controller and related equipment, and then disconnect the power plug from the power source. Performing any replacement procedure with the power ON is extremely hazardous and may result in electric shock and/or malfunction of the robot system.
--	---

 <p>CAUTION</p>	<ul style="list-style-type: none">■ Be careful not to apply excessive shock to the motor shaft during replacement. The shock may shorten the life of the motors and encoder and/or damage them.■ Never disassemble the motor and the encoder. Disassembled motor and encoder will cause a positional gap and cannot be used again.
--	---

After parts have been replaced (motors, reduction gear units, timing belts, etc.), the Manipulator cannot perform positioning properly because a gap exists between the origin stored in each motor encoder and its corresponding origin stored in the Controller.

Therefore, it is necessary to match these origins after replacing the parts. The process of aligning the two origins is called “Calibration”. Refer to *Maintenance 16. Calibration* and perform the calibration after the parts replacement.

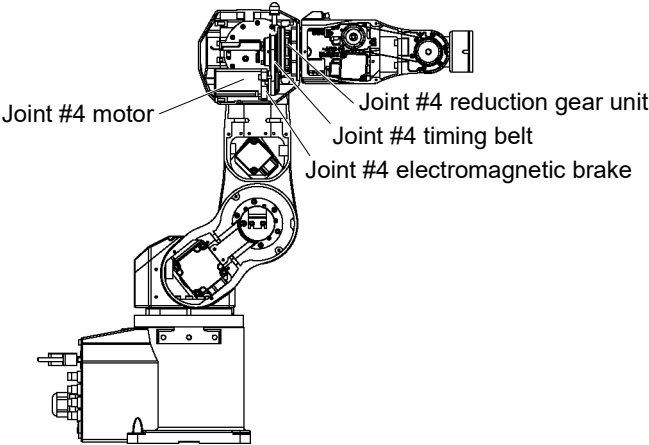

8.1 Joint #4 - Replacing the Motor

	Name		Quantity	Note
Maintenance Parts	AC servo motor 50 W		1	2149265
Tools	Hexagonal wrench	width across flats: 1.5 mm	1	For M3 hexagon socket set screws
		width across flats: 3 mm	1	For M4 hexagon socket head cap bolts
	Cross-point screwdriver		1	For covers
	Force gauge		1	For belt tension adjustment

Removal: Joint #4 Motor

1. Turn OFF the Controller power.
2. Remove the Arm #3 head cover and the Arm #3 bottom cover.
For details, refer to *Maintenance: 3. Covers*.
3. Pull out the cables from the Arm #3 and disconnect the following connectors.

Connector: X141, X041, BT4, BR041

(Hold the clip to remove.)

4. Remove the plate of the control board.
For details, refer to *Maintenance: 13.2 Joint #2 – Replacing the Motor*, Installation steps (3) through (5).

5. Remove the Joint #4 motor unit from the Arm #3.

Hexagon socket head cap bolts: 2-M4×15 (with a small plain washer)

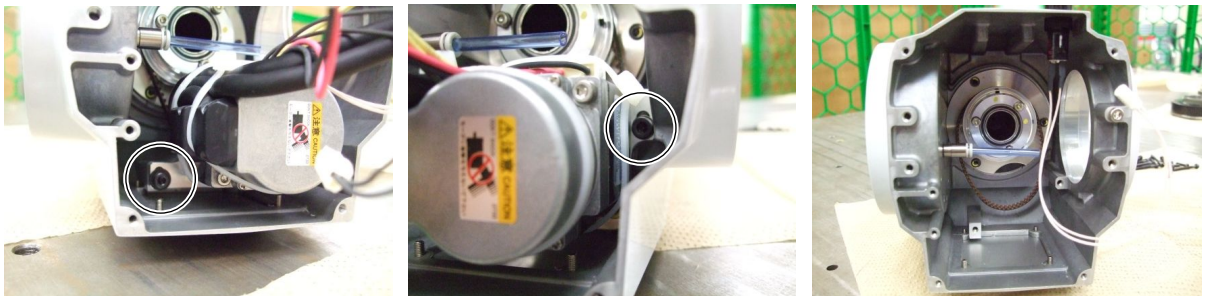
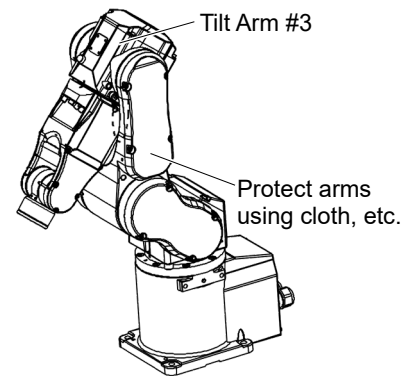

- Cut off the wire tie binding the cables of the Joint #4 motor unit.

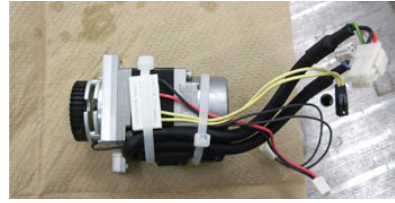

- Remove the Joint #4 pulley 1 and the drive boss from the Joint #4 motor unit.

The drive boss and the pulley fixing:

Hexagon socket set screws: 2-M3×8 (with a brass bushing)

The pulley and the motor shaft fixing:

Hexagon socket set screws: 2-M3×8 (with a brass bushing)

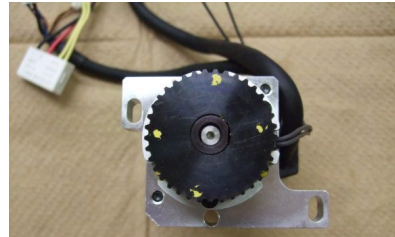

There is a brass bushing in one of the set screw fixing the drive boss and the pulley. Be careful not to lose it.

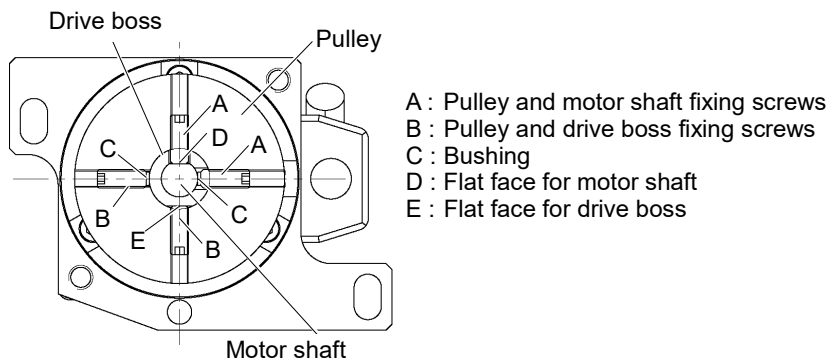

- Remove the Joint #4 electromagnetic brake.

Hexagon socket set screws: 3-M2.5×10

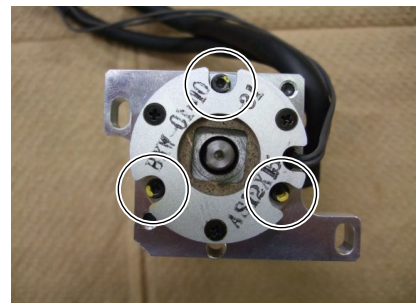

- Remove the motor plate from the Joint #4 motor.

Hexagon socket head cap bolts: 2-M4×12

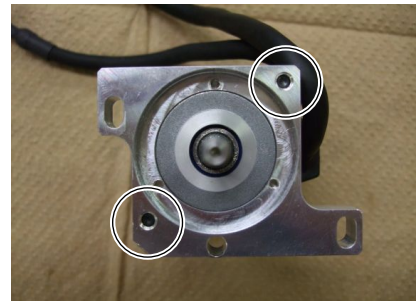

Installation: Joint #4 Motor

1. Install the motor plate to the Joint #4 motor.

Hexagon socket head cap bolts: 2-M4×12

Tightening torque: 4.9 N·m (50 kgf·cm)

Be careful of the direction of the motor plate. (See the photo.)

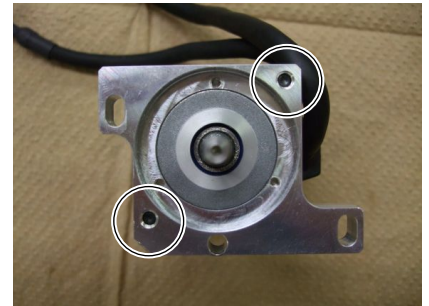

2. Mount the Joint #4 electromagnetic brake to the Joint #4 motor unit.

Hexagon socket set screws: 3-M2.5×10

Be careful of the direction of the Joint #4 electromagnetic brake wiring. (See the photo.)

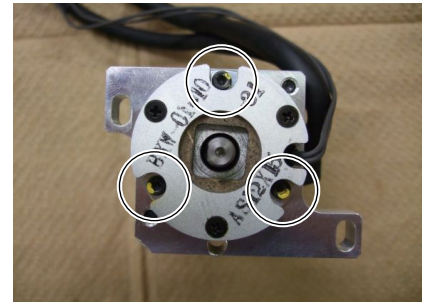

3. Mount the drive boss and the pulley 1 to the Joint #4 motor unit.

Put the end faces of the drive boss and the pulley 1 together.

Hexagon socket set screws: 2-M3×8 (with a brass bushing)

Set the pulley 1 and the motor shaft.

Leave 0.5 mm for the electromagnetic brake.

Hexagon socket set screws: 2-M3×8 (with a brass bushing)

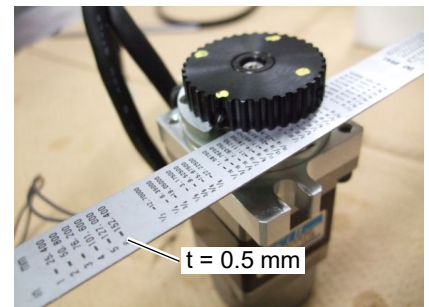

Set the set screws to the positions as indicated below.

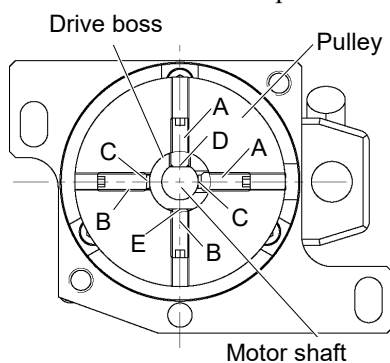

- A : Pulley and motor shaft fixing screws
- B : Pulley and drive boss fixing screws
- C : Bushing
- D : Flat face for motor shaft
- E : Flat face for drive boss

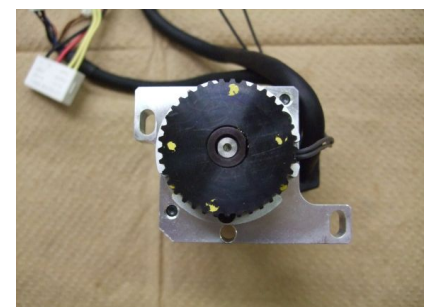

4. Bind the cables of the Joint #4 motor unit with a cable tie.

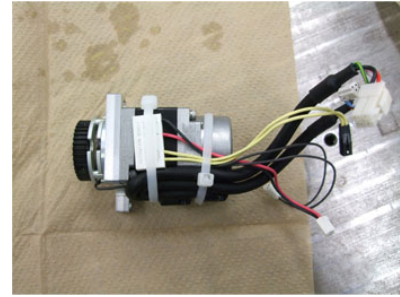

5. Place the Joint #4 timing belt to the Joint #4 pulley 2.

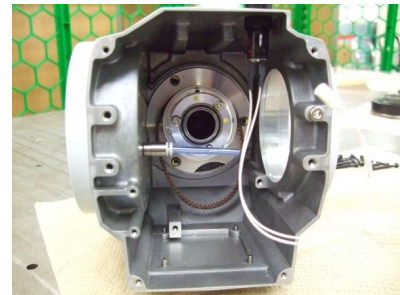

6. Put the Joint #4 motor unit inside the Arm #4.
Place the timing belt around the pulley 1 and pulley 2.

Hexagon socket head cap bolts: 2-M4×15

Check that the teeth of the timing belt engage with these of the pulley.

When securing the motor unit temporarily, make sure that the motor unit can be moved by hand, and it does not tilt when being pulled. If the unit is secured too loose or too tight, the belt will not have proper tension.

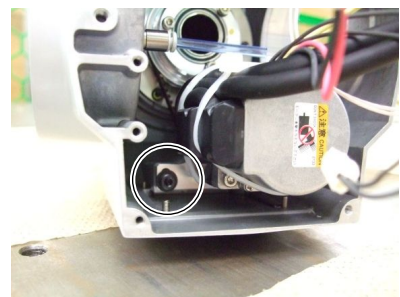
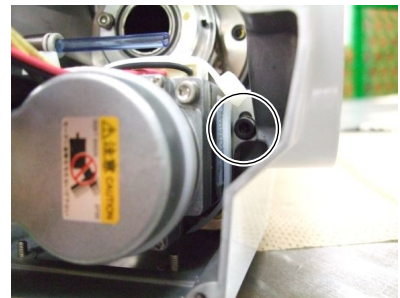

7. Apply tension to the Joint #4 timing belt and fix the Joint #4 motor unit.
Turn ON the Controller and move the Arm #3 to the position where you can apply tension easily.
Turn OFF the Controller power.
Pass a suitable cord or a string (insulation lock) to the drilled hole of the motor plate. Then, pull the cord using a force gauge or a similar tool and apply specified tension to fix the motor unit.

Joint #4 timing belt tension: $39.2 \text{ N} \pm 9.8 \text{ N}$ (4 kgf \pm 1 kgf)

Hexagon socket head cap bolt: 2-M4 \times 15 (with a plain washer)

Tightening torque: 4.9 N·m (50 kgf·cm)

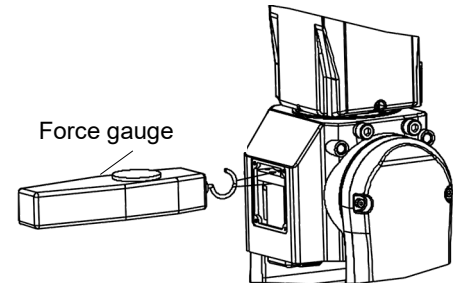

8. Install the control board 2.
For details, refer to *Maintenance: 13.2 Replacing the Control Board 2*, Installation steps (2) through (4).
9. Connect the following connectors.
Connectors: X141, X041, BT4, BR041
10. Install the Arm #3 head cover and the Arm #3 bottom cover.
For details, refer to *Maintenance: 3. Covers*.
11. Calibrate the Joint #4.
For details, refer to *Maintenance: 16. Calibration*.

8.2 Joint #4 - Replacing the Reduction Gear Unit

A reduction gear unit consists of the waveform generator, flexspline, and circular spline. When replacing the reduction gear unit, be sure to replace these parts all together as a set.

For details, refer to *Maintenance: 17. Maintenance Parts List*.

It is recommended replacing the O-rings (for Joint #4) when replacing the reduction gear unit.

	Name	Quantity	Note	
Maintenance Parts	Joint #4 reduction gear unit	1	1533648	
	Joint #4 O-ring	1	1520372	
Tools	Hexagonal wrench	width across flats: 1.5 mm	1	For M3 hexagon socket set screws
		width across flats: 2.5 mm	1	For M3 hexagon socket head cap bolts
		width across flats: 3 mm	1	For M4 hexagon socket head cap bolts
	Cross-point screwdriver	1	For covers	
	Torque wrench	1		
	Spatula	1	For applying grease	
	Force gauge	1	For belt tension adjustment	
	Wiping cloth	1	For wiping grease	

Removal: Joint #4 Reduction gear unit

- Remove the Joint #4 motor unit from the Arm #3.
For details, refer to *Maintenance: 8.1 Joint #4 – Replacing the Motor*, Installation steps (1) through (5).
- Remove the Joint #5 motor unit from the Arm #4.
For details, refer to *Maintenance: 9.1 Joint #5 – Replacing the Motor*, Installation steps (2) through (5).
- Remove the Joint #6 motor unit from the Arm #4.
For details, refer to *Maintenance: 10.1 Joint #6 – Replacing the Motor*, Installation steps (3) through (5).
- Remove the cable unit of the Arm #4.
For details, refer to *Maintenance: 4.1 Replacing the Cable Unit*, Installation steps (9) through (20).
- Remove the Arm #4 cable fixing plate.
Hexagon socket head cap bolts: 2-M4×8
- Remove the Joint #4 timing belt.
- Remove the Joint #4 fitting.
- Remove the LED lamp.

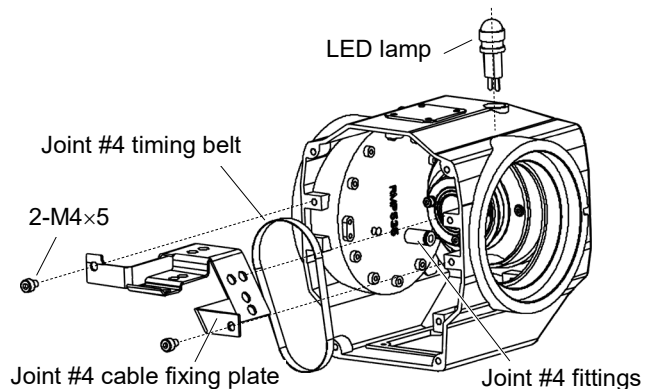

9. Remove the Joint #4 output pulley.

Hexagon socket set screws: 2-M3×8 (with a brass bushing)

There is a brass bushing on the end of the set screw.
Be careful not to lose it.

When removing the Joint #4 output pulley, remove the bearing together.

Hexagon socket head cap bolts: 3-M3×6
(with a spring washer and a plain bushing)

The bearing will be used again. Be careful not to lose it.

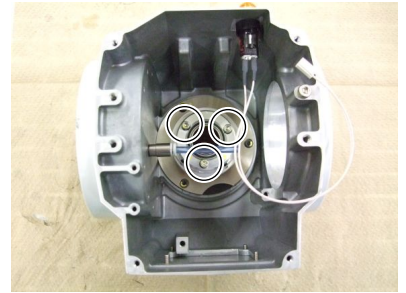

10. Remove the Joint #4 reduction gear unit flange.

Hexagon socket head cap bolts: 3-M3×8

When removing the flange, remove the two bearings and the metal seal together.

The parts will be used again. Be careful not to lose it.

The parts are greased. Wipe grease on the parts while removing them.

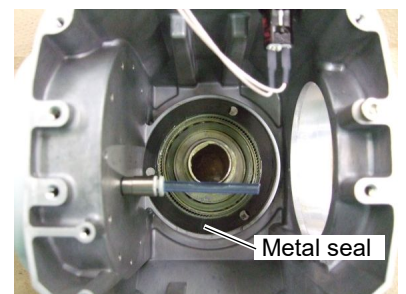

11. Remove the wave generator from the Joint #4 reduction gear unit.

The parts are greased. Wipe grease on the parts while removing them.



12. Remove the circular spline.

Hexagon socket head cap bolts: 12-M3×10

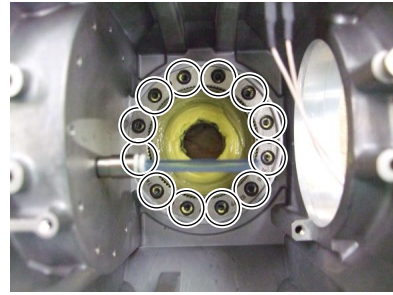

Set the screws to the removal taps of the circular spline and tighten them evenly to remove the circular spline.

Screws: 3-M3×10 or longer

The parts are greased. Wipe grease on the parts while removing them.

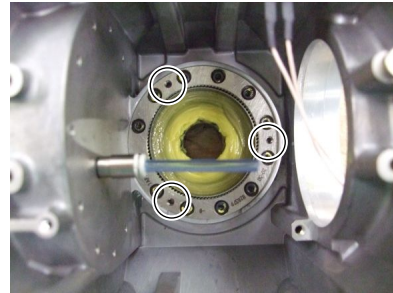

13. Remove the flexspline.

Hexagon socket head cap bolts: 12-M3×10

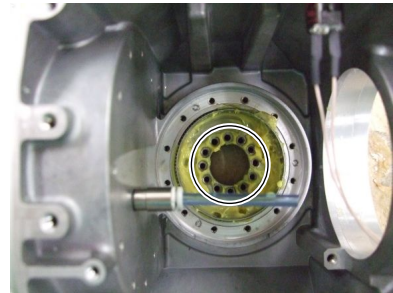

Since the flexspline turns when removing the screws and is difficult to remove, hold the Arm #4 by two workers as shown in the figure.

The parts are greased. Wipe grease on the parts while removing them.



14. Remove the O-rings.

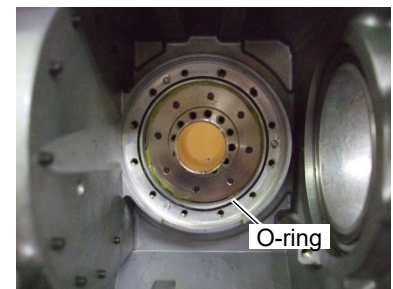

15. Wipe grease using a cloth or a similar material if it is attached to the Arm #3 or other parts.

Installation: Joint #4 Reduction gear unit

1. Unpack the new reduction gear unit package and check if it contains the parts on the right.



2. Grease the tooth surface of the circular spline to fill the groove.

Grease: SK-1A

Grease amount: About to fill the tooth grooves of the circular spline



3. Grease the tooth surface of the flexspline to fill the groove.

Grease: SK-1A

Grease amount: About to fill the tooth grooves of the flexspline



4. Grease the inner side of the flexspline.

Grease: SK-1A

Grease amount: 10 g



5. Grease the bearing of the wave generator.

Grease: SK-1A



6. Install the O-ring to the Arm #4.

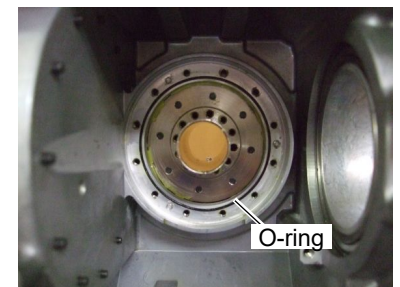

7. Install the circular spline to the Arm #4 with the inscribed side facing up.

Hexagon socket head cap bolts: 12-M3×10

Tightening torque: 2.5 N·m (25 kgf·cm)

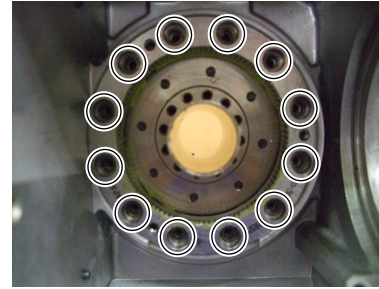

Be careful of the direction of the circular spline.
(See the figure: M3 screw position)

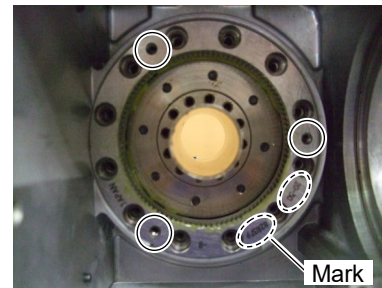

8. Install the flexspline.

Hexagon socket head cap bolts: 12-M3×10

Tightening torque: 2.5 N·m (25 kgf·cm)

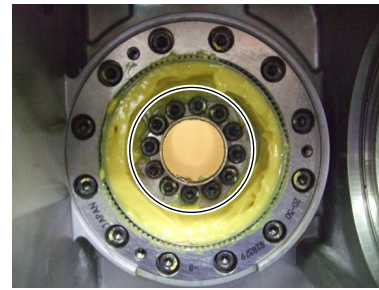

9. Set the bearing to the wave generator and install it to the flexspline.

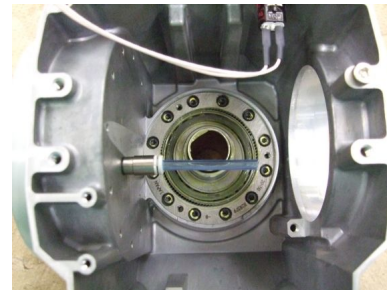

10. Install the metal seal.

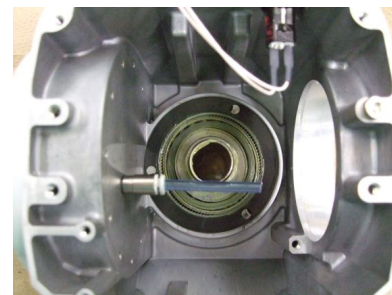

11. Install the bearing to the Joint #4 reduction gear unit flange and insert it to the cylinder of the circular spline.

Hexagon socket head cap bolts: 3-M3×8

Tightening torque: 2.5 N·m (25 kgf·cm)

Be careful of the direction of the flange's cutout.

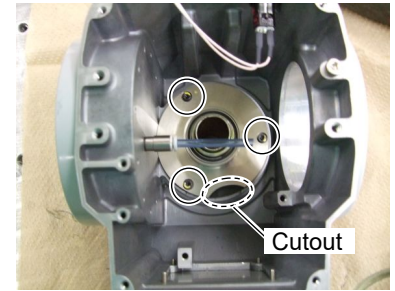

12. Install the Joint #4 output pulley.

Hexagon socket set screws: 2-M3×8 (with a brass bushing)

13. Install the bearing.

Hexagon socket head cap bolts: 3-M3×6
(with a spring washer and a plain bushing)

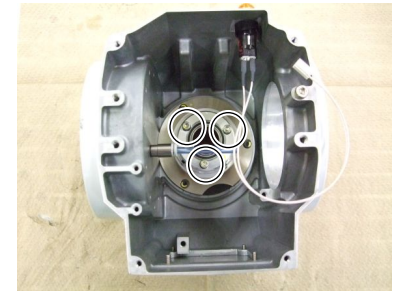

14. Install the LED lamp.

15. Install the Joint #4 fitting.

16. Install the Joint #4 timing belt.

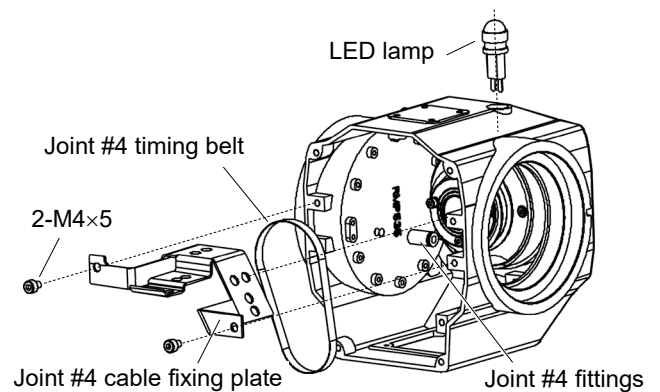

17. Install the Joint #4 motor unit.

For details, refer to *Maintenance: 8.1 Joint #4 – Replacing the Motor*, Installation step (6).

18. Install the Joint #5 motor unit.

For details, refer to *Maintenance: 9.1 Joint #5 – Replacing the Motor*, Installation steps (4) through (5).

19. Install the Joint #6 motor unit.

For details, refer to *Maintenance: 10.1 Joint #6 – Replacing the Motor*, Installation steps (4) through (5).

20. Install the cable unit of the Arm #4.

For details, refer to *Maintenance: 4.1 Replacing the Cable Unit*, Installation steps (4) through (9) and (14) through (38).

21. Apply tension to the Joint #5 motor unit and fix it.

For details, refer to *Maintenance: 9.1 Joint #5 – Replacing the Motor*, Installation step (6).

22. Apply tension to the Joint #6 motor unit and fix it.

For details, refer to *Maintenance: 10.1 Joint #6 – Replacing the Motor*, Installation step (6).

23. Apply tension to the Joint #4 motor unit and fix it.

For details, refer to *Maintenance: 8.1 Joint #4 – Replacing the Motor*, Installation step (7).

24. Install the Arm #3 head cover, the Arm #3 bottom cover, and the Arm #4 side cover.

For details, refer to *Maintenance: 3. Covers*.

25. Perform the calibration.

For details, refer to *Maintenance: 16. Calibration*.

8.3 Joint #4 - Replacing the Timing Belt

	Name	Quantity	Note
Maintenance Parts	Joint #4 timing belt	1	1593699
Tools	Hexagonal wrench (width across flats: 3 mm)	1	For M4 hexagon socket head cap bolts
	Cross-point screwdriver		For covers
	Torque wrench		
	Force gauge	1	For belt tension adjustment

Removal: Joint #4 Timing belt

- Remove the Joint #4 motor unit.
For details, refer to *Maintenance: 8.1 Joint #4 – Replacing the Motor*, Installation steps (1) through (5).
- Remove the Joint #4 timing belt.



Installation: Joint #4 Timing belt

- Place the Joint #4 timing belt around the Joint #4 pulley.
- Install the Joint #4 motor unit.
For details, refer to *Maintenance: 8.1 Joint #4 – Replacing the Motor*, Installation steps (6) through (11).

8.4 Joint #4 - Replacing the Electromagnetic Brake

	Name		Quantity	Note
Maintenance Parts	Joint #4 electromagnetic brake		1	1605913
Tools	Hexagonal wrench	width across flats: 1.5 mm	1	For M3 hexagon socket set screws
		width across flats: 2 mm	1	For M2.5 hexagon socket head cap bolts
		width across flats: 3 mm	1	For M4 hexagon socket head cap bolts
	Cross-point screwdriver		1	For covers
	Nippers		1	
	Torque wrench		1	
	Force gauge		1	For belt tension adjustment

Removal: Joint #4 Electromagnetic brake

- Remove the Joint #4 electromagnetic brake.
For details, refer to *Maintenance: 8.1 Joint #4 – Replacing the Motor*, Installation steps (1) through (8).

Installation: Joint #4 Electromagnetic brake

- Mount the Joint #4 electromagnetic brake to the Joint #4 motor unit.
For details, refer to *Maintenance: 8.1 Joint #4 – Replacing the Motor*, Installation steps (2) through (11).

9. Joint #5



- Do not connect or disconnect the motor connectors while the power to the robot system is turned ON. Connecting or disconnecting the motor connectors with the power ON is extremely hazardous and may result in serious bodily injury as the Manipulator may move abnormally, and also may result in electric shock and/or malfunction of the robot system.
- To shut off power to the robot system, disconnect the power plug from the power source. Be sure to connect the AC power cable to a power receptacle. DO NOT connect it directly to a factory power source.
- Before performing any replacement procedure, turn OFF the Controller and related equipment, and then disconnect the power plug from the power source. Performing any replacement procedure with the power ON is extremely hazardous and may result in electric shock and/or malfunction of the robot system.



- Be careful not to apply excessive shock to the motor shaft during replacement. The shock may shorten the life of the motors and encoder and/or damage them.
- Never disassemble the motor and the encoder. Disassembled motor and encoder will cause a positional gap and cannot be used again.

After parts have been replaced (motors, reduction gear units, electromagnetic brakes, timing belts, etc.), the Manipulator cannot perform positioning properly because a gap exists between the origin stored in each motor encoder and its corresponding origin stored in the Controller.

Therefore, it is necessary to match these origins after replacing the parts.

The process of aligning the two origins is called “Calibration”.

Refer to *Maintenance 16. Calibration* and perform the calibration after the parts replacement.

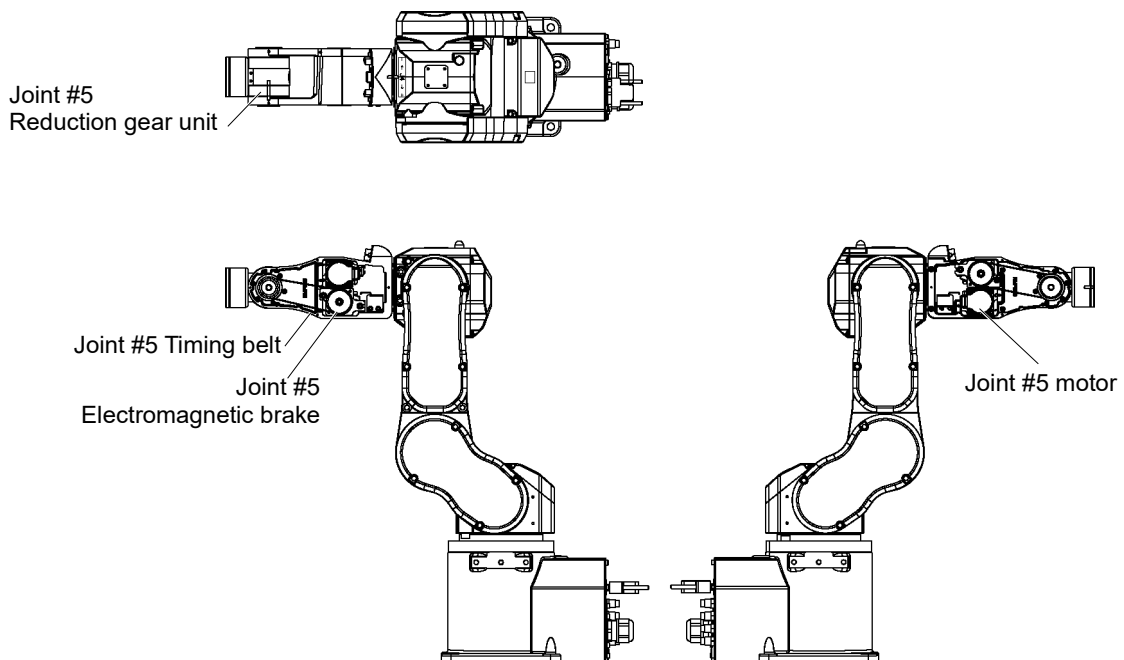

9.1 Joint #5 - Replacing the Motor

	Name	Quantity	Note	
Maintenance Parts	AC servo motor 50 W	1	2149265	
Tools	Hexagonal wrench	width across flats: 1.5 mm	1	For M3 hexagon socket set screws
		width across flats: 2 mm	1	For M2.5 hexagon socket head cap bolts
		width across flats: 3 mm	1	For M4 hexagon socket head cap bolts
	Cross-point screwdriver	1	For covers	
	Nippers	1		
	Force gauge	1	For belt tension adjustment	

The brake is mounted on the Joint #5 to prevent the arm from lowering due to its own weight while the Controller power is OFF or the motor is OFF status. However, the brake does not work during replacement.

Removal: Joint #5 Motor

1. Turn OFF the Controller power.
2. Remove the Arm #4 side cover.
For details, refer to *Maintenance: 3. Covers*.
3. Pull out the cables from the Arm #4 and disconnect the following connectors.

Connectors: X052, X152, BT52, BR052

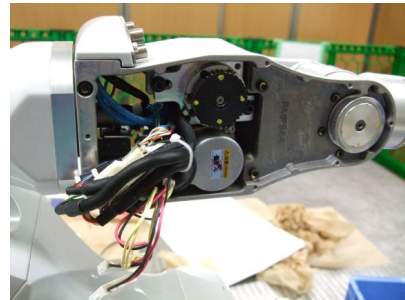

4. Loosen the bolts securing the Joint #5 motor unit and remove the belt.

Hexagon socket head cap bolts: 2-M4×15 (with a plain washer)



5. Remove the Joint #5 motor unit.

Hexagon socket head cap bolts: 2-M4×15 (with a plain washer)

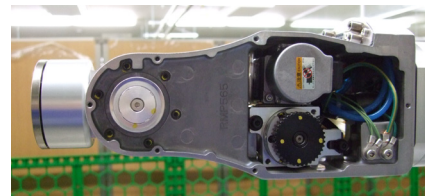

- Remove the Joint #5 pulley 1 and the drive boss from the motor shaft of the Joint #5 motor unit.

Drive boss and the pulley fixing screws:

Hexagon socket set screws: 2-M3×8 (with a brass bushing)

Pulley and the motor shaft fixing screws:

Hexagon socket set screws: 2-M3×8 (with a brass bushing)

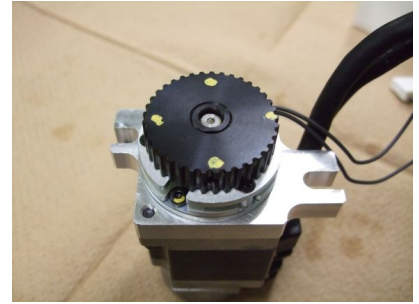

There is a brass bushing in one of the set screws fixing the drive boss and the pulley. Be careful not to lose it.

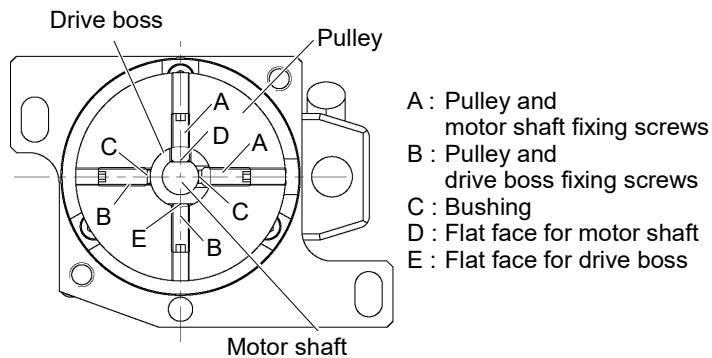

- Remove the Joint #5 electromagnetic brake.

Hexagon socket set screws: 3-M2.5×10

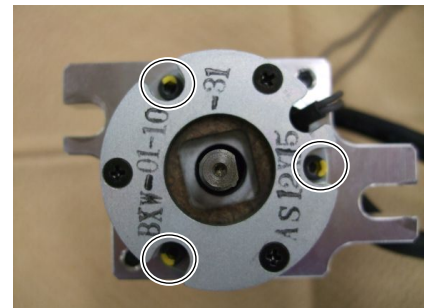

- Remove the motor plate from the Joint #5 motor.

Hexagon socket head cap bolts: 2-M4×12

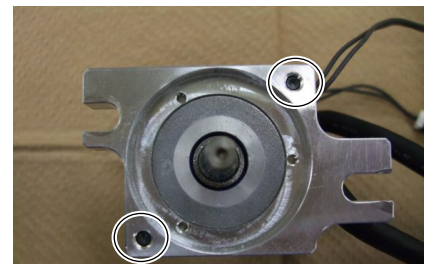

Installation: Joint #5 Motor

1. Install the motor plate to the Joint #5 motor.

Hexagon socket head cap bolts: 2-M4×12

Tightening torque: 4.9 N·m (50 kgf·cm)

Be careful of the direction of the motor plate. (See the photo.)

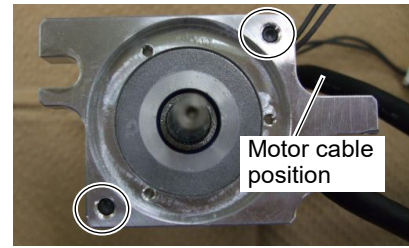

2. Mount the Joint #5 electromagnetic brake to the Joint #5 motor unit.

Hexagon socket set screws: 3-M2.5×10

Be careful of the direction of the Joint #5 electromagnetic brake wiring. (See the photo.)

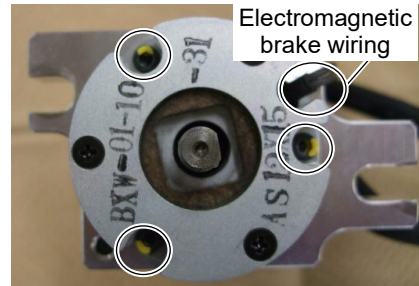

3. Mount the drive boss and the pulley 1 to the Joint #5 motor unit.

Set the drive boss and the pulley 1 so that their surfaces become flat.

Hexagon socket set screws: 2-M3×8 (with a brass bushing)

Fix the pulley 1 and the motor shaft.

Leave 0.5 mm for the electromagnetic brake.

Hexagon socket set screws: 2-M3×8 (with a brass bushing)

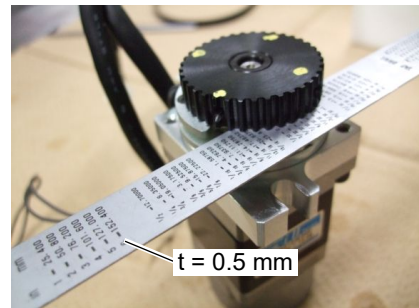

Set the set screws as indicated below.

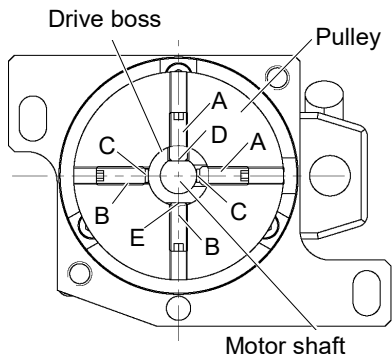

- A : Pulley and motor shaft fixing screws
- B : Pulley and drive boss fixing screws
- C : Bushing
- D : Flat face for motor shaft
- E : Flat face for drive boss



4. Put the Joint #5 motor unit to the Arm #4.
5. Place the timing belt around the pulley 1 and pulley 2.
Make sure that the teeth of the timing belt engage with these of the pulley.

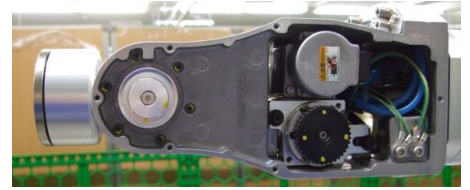

When securing the motor unit temporarily, make sure that the motor unit can be moved by hand, and it does not tilt when being pulled. If the unit is secured too loose or too tight, the belt will not have proper tension.

6. Apply tension to the Joint #5 motor unit and fix it.



Joint #5 Timing belt tension = $39.2 \text{ N} \pm 9.8 \text{ N}$ (4 kgf \pm 1 kgf)

Secure the Joint #5 motor unit by applying tension.

Hexagon socket head cap bolts: 2-M4 \times 15 (with a plain washer)

Tightening torque: 4.9 N \cdot m (50 kgf \cdot cm)

7. Connect the following connectors.
Connectors: X052, X152, BT52, BR052
8. Install the Arm #4 side cover.
For details, refer to *Maintenance: 3. Covers*.
9. Perform the calibration.
For details, refer to *Maintenance: 16. Calibration*.

9.2 Joint #5 - Replacing the Reduction Gear Unit

A reduction gear unit consists of the waveform generator, flexspline, and circular spline. When replacing the reduction gear unit, be sure to replace these parts all together as a set.

For details, refer to *Maintenance: 17. Maintenance Parts List*.

	Name		Quantity	Note
Maintenance Parts	Joint #5 reduction gear unit		1	1539260
Tools	Hexagonal wrench	width across flats: 1.5 mm	1	For M3 hexagon socket set screws For M2 hexagon socket head cap bolts
		width across flats: 2 mm	1	For M2.5 hexagon socket head cap bolts
		width across flats: 2.5 mm	1	For M3 hexagon socket head cap bolts
		width across flats: 3 mm	1	For M4 hexagon socket head cap bolts
	Cross-point screwdriver		1	For covers
	Wrench	width 7	1	
		width 8	1	
Force gauge		1	For belt tension adjustment	

Removal: Joint #5 Reduction gear unit

1. Turn OFF the Controller power.
2. Remove the Arm #4 side cover.
For details, refer to *Maintenance: 3. Covers*.
3. Loosen the set screws of the Joint #5 motor unit and remove the Joint #5 timing belt (6×315 mm).
Hexagon socket head cap bolts: 2-M4×15 (with a plain washer)
4. Loosen the set screws of the Joint #6 motor unit and remove the Joint #6 timing belt (6×324 mm).
Hexagon socket head cap bolts: 2-M4×15 (with a plain washer)

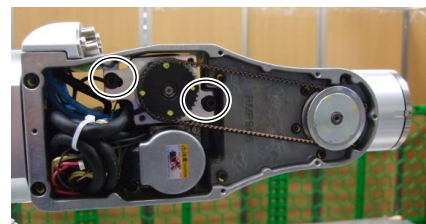
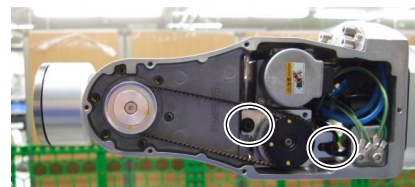

- Loosen the set screws of the pulley 2 and remove the Joint #5 pulley 2.

Hexagon socket set screws: 2-M3×5 (with a brass bushing)

There is a brass bushing in one of the set screws.
Be careful not to lose it.

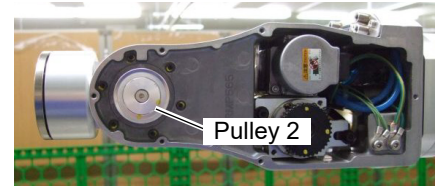

- Loosen the set screws of the pulley 2 and remove the Joint #6 pulley 2.

Hexagon socket set screws: 2-M3×5 (with a brass bushing)

There is a brass bushing in one of the set screws.
Be careful not to lose it.

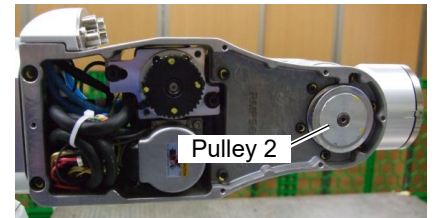

- Remove the bearing retainer plate.

Hexagon socket head cap bolts: 4-M3×6



- Pull out the gear unit.

If it is difficult to remove the gear unit, install the removed pulley 2 to the shaft and remove the parts.



The bearing of the gear unit has shim rings.
Check the position and the number of the shim rings.

When installing the gear unit, make sure to use the same number of the shim rings to the same position.



- Remove the Arm #4 plate.

Hexagon socket head cap bolts: 6-M3×12

Hexagon socket head cap bolts: 4-M4×10

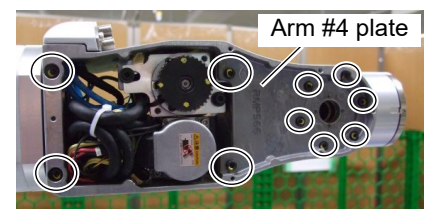

10. Remove the Joint #6 flange unit.

Hexagon socket head cap bolts: 6-M3×15

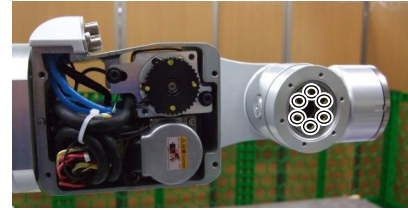

11. Loosen the set screws securing the Joint #5 reduction gear unit and remove the Arm #5 unit.

Hexagon socket head cap bolts: 6-M3×15



The parts are greased. Wipe grease on the parts while removing them.

12. Remove the O-rings.

The O-rings are on the installation surfaces of the Arm #4 and #5. The O-ring of the Arm #4 is on the Arm #4 plate which was removed in the step (9).

For the O-ring of the Arm #5, see the photo on the right.

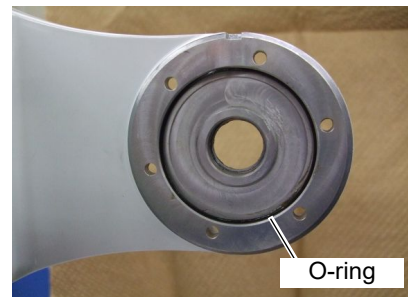

13. Remove the wave generator from the reduction gear unit.

If it is difficult to remove the wave generator unit, install the removed pulley 2 to the shaft and remove the parts.

When removing the wave generator, the bearing on the end of the shaft comes off together. Do not lose the bearing.

The parts are greased. Wipe grease on the parts while removing them.



14. Remove the wave generator from the shaft.

Remove the bearing. The bearing will be used again. Be careful not to lose it.

There is a washer between the nut and the wave generator.

Be careful not to lose it.

The parts are greased. Wipe grease on the parts while removing them.

Open-end wrench width for the shaft: 7 mm

Open-end wrench width for the nut: 8 mm

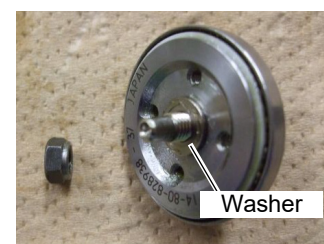

15. Unscrew the set screws of the circular spline and the flexspline.

Circular spline fixing bolts:

Hexagon socket head cap bolts: 3-M2×10

Flexspline fixing bolts:

Hexagon socket head cap bolts: 6-M3×8

The parts are greased. Wipe grease on the parts while removing them.



16. Remove the circular spline and the flexspline.

The parts are greased. Wipe grease on the parts while removing them.



17. Remove the O-ring of the housing.



Installation: Joint #5 Reduction gear unit

1. Unpack the new reduction gear unit package and check if it contains the parts on the right.

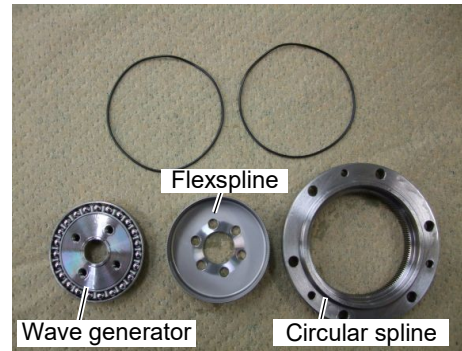

2. Grease all over the tooth surface of the flexspline.

Grease: SK-2

Grease amount: About to fill the tooth groove of the flexspline.



3. Grease all over the tooth surface of the circular spline.

Grease: SK-2

Grease amount: About to fill the tooth groove of the circular spline.

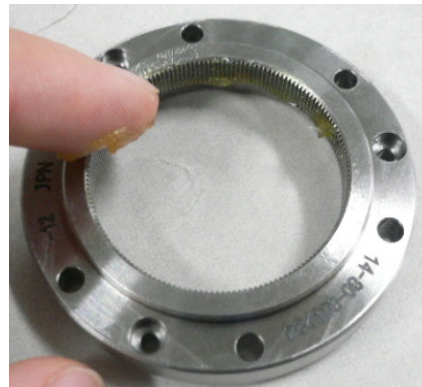

4. Install the removed bearing to the Arm #5.



5. Install the O-ring (of the Joint #5 reduction gear unit) to the housing.



6. Install the flexspline so that the hole on the inner side can match the bearing's outer ring.

Hexagon socket head cap bolts: 6-M3×8

Tightening torque: 2.5 N·m (25 kgf·cm)



7. Install the circular spline.

Hexagon socket head cap bolts: 3-M2×10



8. Grease the inner side of the flexspline.

Grease: SK-2

Grease amount: 3 g

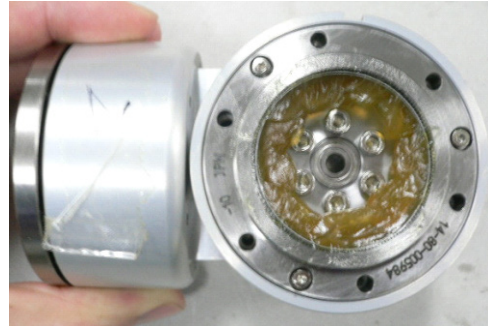

9. Install the wave generator to the shaft.

Insert the washer between the nut and the wave generator.

Set an open-end wrench to the shaft and turn the nut.

Open-end wrench width for the shaft: 7 mm

Open-end wrench width for the nut: 8 mm



10. Grease the bearing of the wave generator.

Grease: SK-2

Grease amount: About to fill space between the balls.



11. Insert the wave generator to the reduction gear unit.

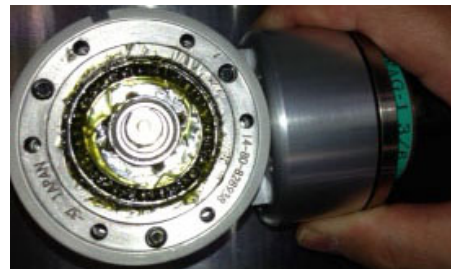

12. Install the O-ring (of the Joint #5 reduction gear unit) to the Arm #4.

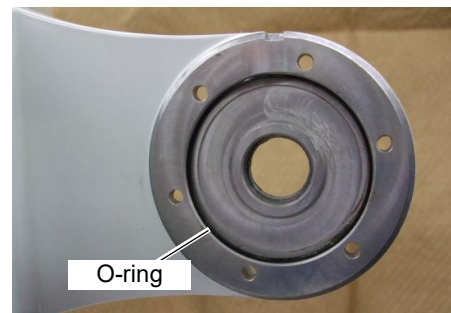

13. Install the Arm #5 unit to the Arm #4.

Hexagon socket head cap bolts: 6-M3×15

Tightening torque: 2.5 N·m (25 kgf·cm)

When installing the unit, insert the key to the groove and match the grooves of the Arm #4 and the housing, then tighten the screws. Return the key to its original position after tightening the screws.

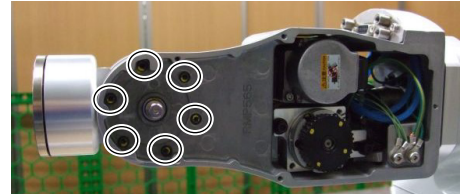
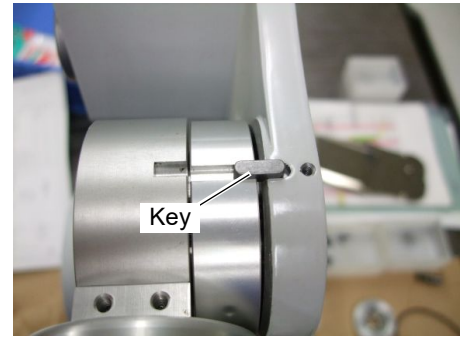

The key is on the Arm #1, under the Arm #1 upper cover.
Hexagon socket head cap bolts: M3×6

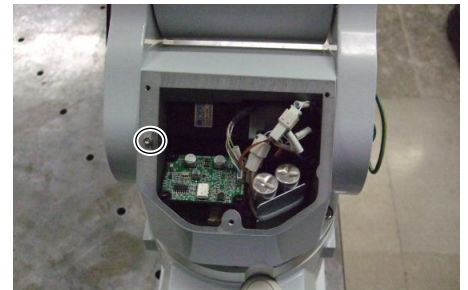

14. Install the Joint #6 flange unit.

Hexagon socket head cap bolt: 6-M3×15

Tightening torque: 2.5 N·m (25 kgf·cm)

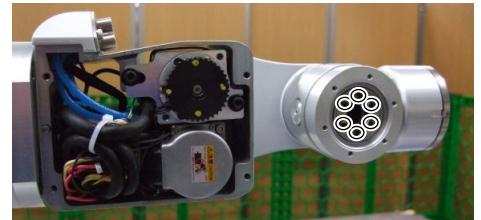

15. Install the Arm #4 plate.

Hexagon socket head cap bolts: 6-M3×12

Tightening torque: 2.5 N·m (25 kgf·cm)

Hexagon socket head cap bolts: 4-M4×10

Tightening torque: 4.9 N·m (50 kgf·cm)

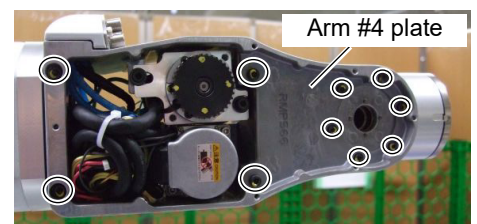

16. Insert the gear unit.

The bearing of the gear unit has shim rings. Insert them together.

Use the same number of the shim rings to the same position as removed shim rings.

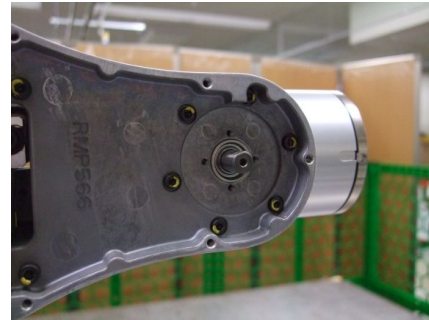

17. Install the bearing retainer plate.

Hexagon socket head cap bolts: 4-M3×6

Tightening torque: 2.5 N·m (25 kgf·cm)

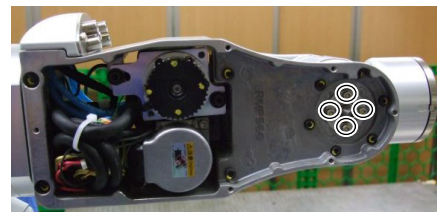

18. Install the Joint #6 pulley 2.

Hexagon socket set screws: 2-M3×5 (with a brass bushing)

Set the set screw on the flat face of the shaft. For the other set screw, insert the brass bushing to the end.

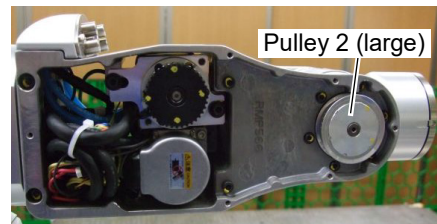

19. Place the Joint #6 timing belt (6×324 mm) to the Pulley 1 and 2 and fix it temporarily.

Check that the teeth of the timing belt engage with these of the pulley.

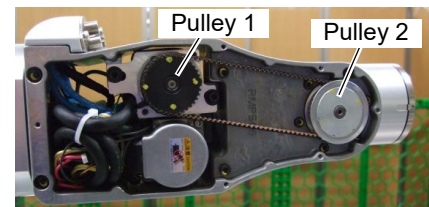

When securing the motor unit temporarily, make sure that the motor unit can be moved by hand, and it does not tilt when being pulled. If the unit is secured too loose or too tight, the belt will not have proper tension.

20. Apply tension to the Joint #6 motor unit and fix it.

Joint #6 timing belt tension = $39.2 \text{ N} \pm 9.8 \text{ N}$ (4 kgf \pm 1 kgf)

Secure the Joint #6 motor unit by applying tension.

Hexagon socket head cap bolts: 2-M4×15 (with a plain washer)

Tightening torque: 4.9 N·m (50 kgf·cm)

21. Install the Joint #5 pulley 2.

Hexagon socket set screw: 2-M3×5 (with a brass bushing)

Set the set screw on the flat face of the shaft. For the other set screw, insert the brass bushing to the end.

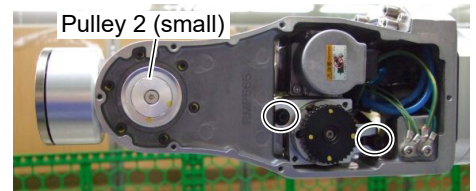

22. Place the Joint #5 timing belt (6×315 mm) around the Pulley 1 and 2 and fix it temporarily.

Check that the teeth of the timing belt engage with these of the pulleys.

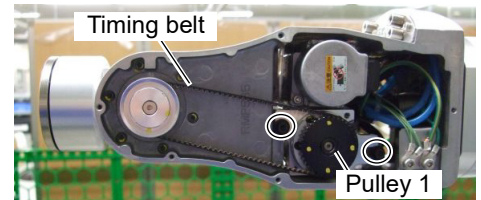

When securing the motor unit temporarily, make sure that the motor unit can be moved by hand, and it does not tilt when being pulled. If the unit is secured too loose or too tight, the belt will not have proper tension.

23. Apply tension to the Joint #5 motor unit and fix it.

Joint #5 timing belt tension = $39.2 \text{ N} \pm 9.8 \text{ N}$ (4 kgf \pm 1 kgf)

Secure the Joint #5 motor unit by applying tension.

Hexagon socket head cap bolt: 2-M4×15 (with a plain washer)

Tightening torque: 4.9 N·m (50 kgf·cm)

24. Install the Arm #4 side cover.

For details, refer to *Maintenance: 3. Covers*.

25. Perform the calibration.

For details, refer to *Maintenance: 16. Calibration*.

9.3 Joint #5 - Replacing the Timing Belt

	Name	Quantity	Note
Maintenance Parts	Joint #5 timing belt (315 mm)	1	1599367
Tools	Hexagonal wrench (width across flats: 2.5 mm)	1	For M4 hexagon socket head cap bolts
	Cross-point screwdriver	1	For covers
	Force gauge	1	For belt tension adjustment

Removal: Joint #5 Timing belt

1. Turn OFF the Controller power.
2. Remove the Arm #4 side cover.
For details, refer to *Maintenance: 3. Covers*.
3. Loosen the Joint #5 motor unit set screws.
Hexagon socket head cap bolts: 2-M4×15
(with a plain washer)
4. Remove the Joint #5 timing belt.

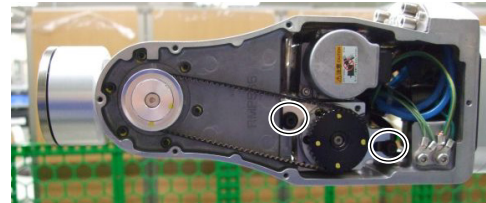

Installation: Joint #5 Timing belt.

1. Place the Joint #5 timing belt to the pulley 1 and the pulley 2 of the Joint #5.
2. Secure the Joint #5 motor unit.
For details, refer to *Maintenance: 9.1 Joint #5 – Replacing the Motor*, Installation steps (5), (6), (8), and (9).

9.4 Joint #5 - Replacing the Electromagnetic Brake

	Name	Quantity	Note
Maintenance Parts	Joint #5 electromagnetic brake	1	1605913
Tools	Hexagonal wrench (width across flats: 1.5 mm)	1	For M3 hexagon socket set screws
	Hexagonal wrench (width across flats: 2 mm)	1	For M2.5 hexagon socket head cap bolts
	Hexagonal wrench (width across flats: 3 mm)	1	For M4 hexagon socket head cap bolts
	Cross-point screwdriver	1	For covers
	Nippers	1	
	Force gauge	1	For belt tension adjustment

Removal: Joint #5 Electromagnetic brake

1. Remove the Joint #5 electromagnetic brake.
For details, refer to *Maintenance: 9.1 Joint #5 – Replacing the Motor*, Installation steps (1) through (7).

Installation: Joint #5 Electromagnetic brake

1. Mount the Joint #5 electromagnetic brake to the Joint #5 motor unit.
For details, refer to *Maintenance: 9.1 Joint #5 – Replacing the Motor*, Installation steps (2) through (9).

10. Joint #6

 WARNING	<ul style="list-style-type: none"> ■ Do not connect or disconnect the motor connectors while the power to the robot system is turned ON. Connecting or disconnecting the motor connectors with the power ON is extremely hazardous and may result in serious bodily injury as the Manipulator may move abnormally, and also may result in electric shock and/or malfunction of the robot system. ■ To shut off power to the robot system, disconnect the power plug from the power source. Be sure to connect the AC power cable to a power receptacle. DO NOT connect it directly to a factory power source. ■ Before performing any replacement procedure, turn OFF the Controller and related equipment, and then disconnect the power plug from the power source. Performing any replacement procedure with the power ON is extremely hazardous and may result in electric shock and/or malfunction of the robot system.
--	---

 CAUTION	<ul style="list-style-type: none"> ■ Be careful not to apply excessive shock to the motor shaft during replacement. The shock may shorten the life of the motors and encoder and/or damage them. ■ Never disassemble the motor and the encoder. Disassembled motor and encoder will cause a positional gap and cannot be used again.
--	--

After parts have been replaced (motors, reduction gear units, electromagnetic brakes, timing belts, etc.), the Manipulator cannot perform positioning properly because a gap exists between the origin stored in each motor encoder and its corresponding origin stored in the Controller.

Therefore, it is necessary to match these origins after replacing the parts.

The process of aligning the two origins is called “Calibration”.

Refer to *Maintenance 16. Calibration* and perform the calibration after the parts replacement.

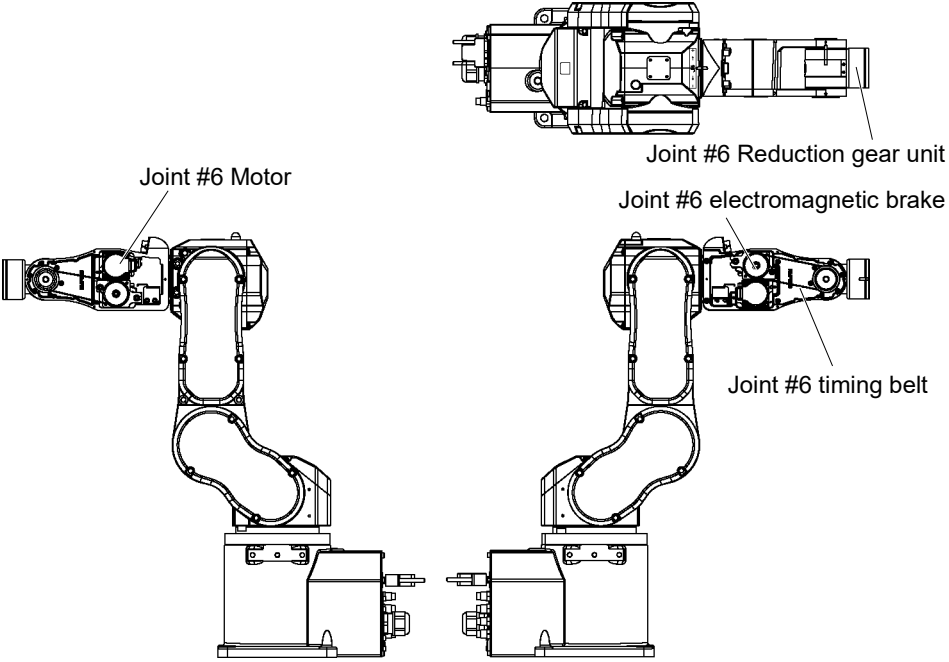

10.1 Joint #6 - Replacing the Motor

	Name	Quantity	Note	
Maintenance Parts	AC servo motor 50 W	1	2149265	
Tools	Hexagonal wrench	width across flats: 1.5 mm	1	For M3 hexagon socket set screws
		width across flats: 2 mm	1	For M2.5 hexagon socket head cap bolts
		width across flats: 3 mm	1	For M4 hexagon socket head cap bolts
	Cross-point screwdriver	1	For covers	
	Nippers	1		
	Force gauge	1	For belt tension adjustment	

The brake is mounted on the Joint #6 to prevent the arm from lowering due to its own weight while the Controller power is OFF or the motor is OFF status. However, the brake does not work during replacement.

Removal: Joint #6 Motor

1. Turn OFF the Controller power.
2. Remove the Arm #4 side cover.
For details, refer to *Maintenance: 3. Covers*.
3. Pull out the cables from the Arm #4 and disconnect the following connectors.

Connectors: X062, X162, BT62, BR062

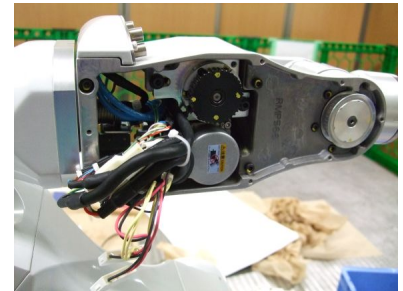

4. Loosen the bolts securing the Joint #6 motor unit and remove the belts.

Hexagon socket head cap bolts: 2-M4×15 (with a plain washer)

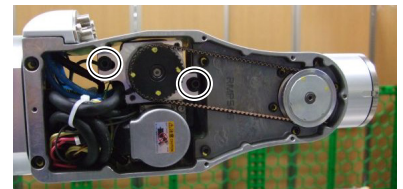

5. Remove the Joint #6 motor unit.

Hexagon socket head cap bolts: 2-M4×15 (with a plain washer)

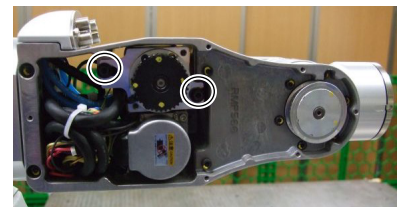

- 6. Remove the Joint #6 pulley 1 and the drive boss from the Joint #6 motor unit.

The drive boss and the pulley fixing screws:

Hexagon socket set screws: 2-M3×8 (with a brass bushing)

Pulley and the motor shaft fixing screws:

Hexagon socket set screws: 2-M3×8 (with a brass bushing)

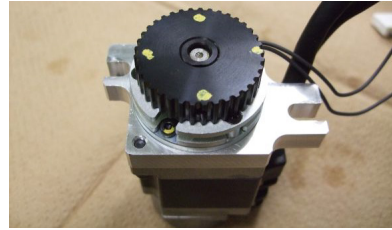

There is a brass bushing in one of the set screws fixing the drive boss and the pulley. Be careful not to lose it.

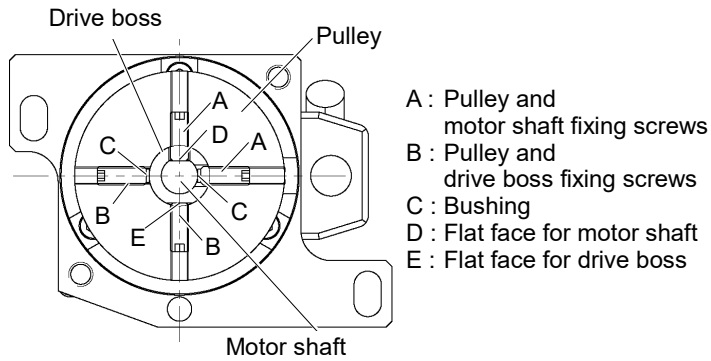

- 7. Remove the Joint #6 electromagnetic brake.

Hexagon socket set screws: 3-M2.5×10

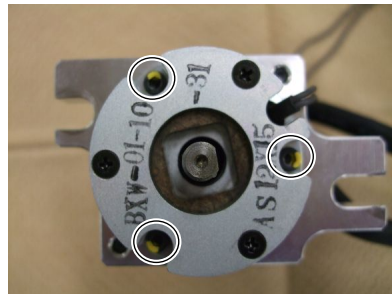

- 8. Remove the motor plate from the Joint #6 motor.

Hexagon socket head cap bolts: 2-M4×12

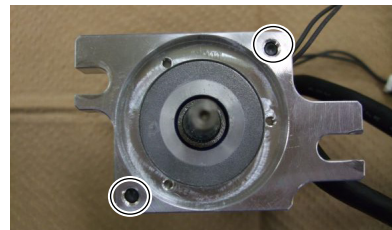

Installation: Joint #6 motor

1. Install the motor plate to the Joint #6 motor.

Hexagon socket head cap bolts: 2-M4×12

Tightening torque: 4.9 N·m (50 kgf·cm)

Be careful of the direction of the motor plate. (See the photo.)

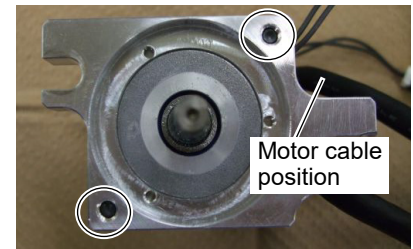

2. Mount the Joint #6 electromagnetic brake to the Joint #6 motor unit.

Hexagon socket set screws: 3-M2.5×10

Be careful of the direction of the Joint #6 electromagnetic brake wiring. (See the figure.)

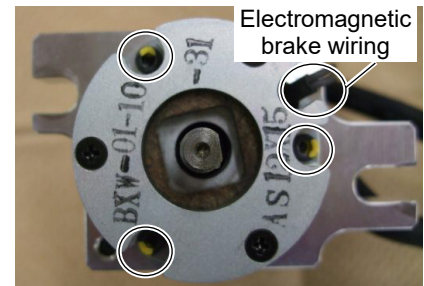

3. Mount the drive boss and the pulley 1 to the Joint #6 motor unit.

Set the drive boss and the pulley 1 so that their surfaces become flat.

Hexagon socket set screws: 2-M3×8 (with a brass bushing)

Set the pulley 1 and the motor shaft.

Leave 0.5 mm for the electromagnetic brake.

Hexagon socket set screws: 2-M3×8 (with a brass bushing)

Set the set screws as indicated below.

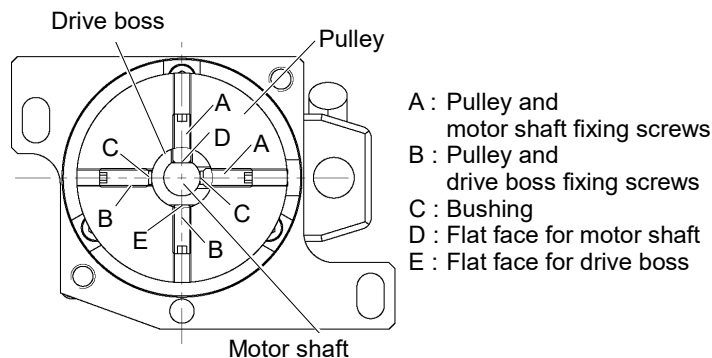
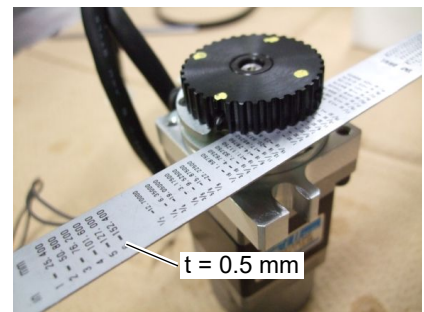

4. Put the Joint #6 motor unit to the Arm #4.
5. Place the timing belt around the pulley 1 and pulley 2.

Make sure that the teeth of the timing belt engage with these of the pulley.

When securing the motor unit temporarily, make sure that the motor unit can be moved by hand, and it does not tilt when being pulled. If the unit is secured too loose or too tight, the belt will not have proper tension.

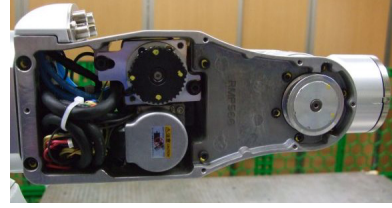

6. Apply tension to the Joint #6 motor unit and fix it.
Joint #6 timing belt tension = $39.2 \text{ N} \pm 9.8 \text{ N}$ (4 kgf \pm 1 kgf)

Secure the Joint #6 motor unit by applying tension.

Hexagon socket head cap bolts: 2-M4 \times 15 (with a plain washer)

Tightening torque: 4.9 N \cdot m (50 kgf \cdot cm)

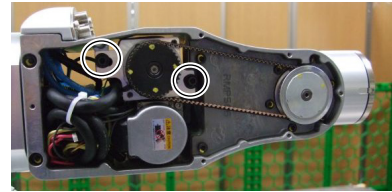

7. Connect the following connectors.
Connectors: X062, X162, BT62, BR062
8. Install the Arm #4 side cover.
For details, refer to *Maintenance: 3. Covers.*
9. Perform the calibration.
For details, refer to *Maintenance: 16. Calibration.*

10.2 Joint #6 - Replacing the Reduction Gear Unit

	Name		Quantity	Note
Maintenance Parts	Joint #6 reduction gear unit		1	1539261
Tools	Hexagonal wrench	width across flats: 1.5 mm	1	For M3 hexagon socket set screws For M2 hexagon socket head cap bolts
		width across flats: 2 mm	1	For M2.5 hexagon socket head cap bolts
		width across flats: 2.5 mm	1	For M3 hexagon socket head cap bolts
		width across flats: 3 mm	1	For M4 hexagon socket head cap bolts
	Cross-point screwdriver		1	For covers
	Wrench	width 5.5	1	
		width 8	1	
Force gauge		1	For belt tension adjustment	

Removal: Joint #6 Reduction gear unit

1. Turn OFF the Controller power.
2. Remove the Arm #4 side cover.
For details, refer to *Maintenance: 3. Covers*.
3. Remove the Joint #5 motor unit and the reduction gear unit.
For details, refer to *Maintenance: 9.2 Joint #5 – Replacing the Motor*, Installation steps (3) through (11).

4. Remove the O-ring on the installation surface of the Arm #4 and #5.
The O-ring of the Arm #4 is on the Arm #4 plate which was removed in the step (4).

For the O-ring of the Arm #5, see the photo on the right.

The O-ring will be used again. Be careful not to lose it.

5. Remove the Joint #6 flange.

Hexagon socket head cap bolts: 7-M3×6

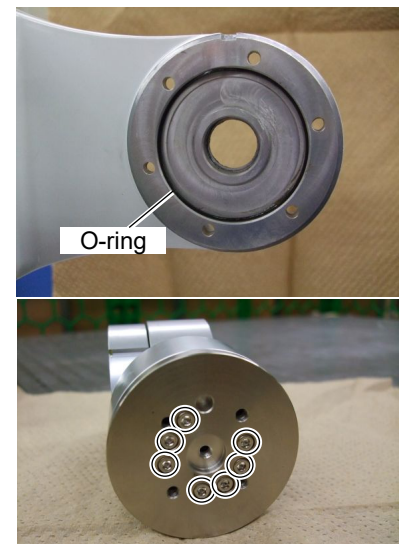

- 6. Remove the Joint #6 reduction gear unit from the Arm #5.
Use a wrench to move the through holes of the screws. Insert a tool from the back side of the arm to push the reduction gear unit.

Hexagon socket head cap bolt: 6-M3×28

The parts are greased. Wipe grease on the parts while removing them.

- 7. Remove the O-ring of the Arm #5.

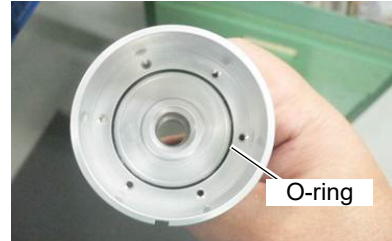

- 8. Unplug the Arm #5 plug.

Set the screw to the plug and pull out.

Recommended screw length: M4×15 mm or longer

The parts are greased. Wipe grease on the parts while removing them.



- 9. Remove the gear.

Remove the bearing. Set the open-end wrench to the nut on the Joint #6 reduction gear unit. Insert the tool to the hole where the plug was, and then turn the screw to remove.

Hexagon socket head cap bolt: 1-M3×8 (with a plain washer)

The parts are greased. Wipe grease on the parts while removing them.

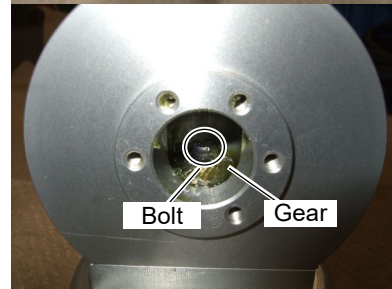
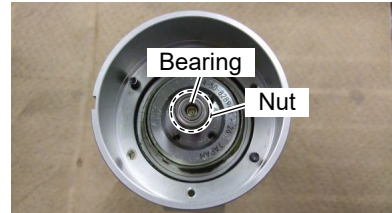

- 10. Remove the wave generator from the Arm #5.

The parts are greased. Wipe grease on the parts while removing them.



11. Remove the wave generator from the shaft.

If the shaft has a bearing, remove it. The bearing will be used again. Be careful not to lose it.

There is a washer between the nut and the wave generator.
Be careful not to lose it.

The parts are greased. Wipe grease on the parts while removing them.

Open-end wrench width for the shaft: 5.5 mm

Open-end wrench width for the nut: 8 mm



Installation: Joint #6 Reduction gear unit

1. Unpack the new reduction gear unit package and check if it contains the parts on the right.

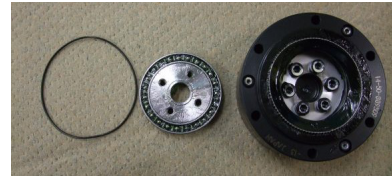

2. Install the wave generator to the shaft.

Insert the washer between the nut and the wave generator.

Set an open-end wrench to the shaft and turn the nut.

Open-end wrench width for the shaft: 5.5 mm

Open-end wrench width for the nut: 8 mm

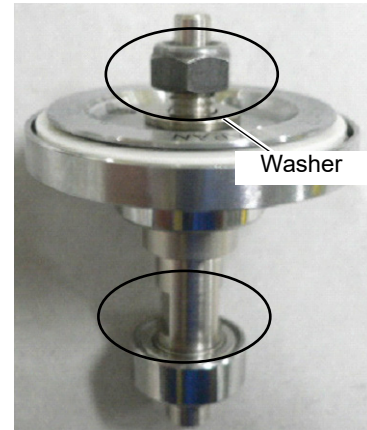

3. Install the O-ring (of the Joint #6 reduction gear unit) to the Arm #5.

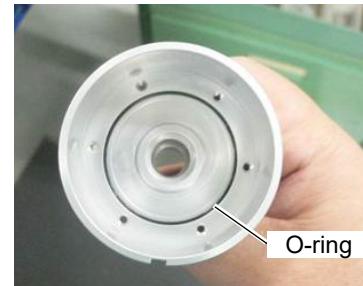

4. Insert the wave generator unit to the Arm #5.



5. Install the gear.

Set the open-end wrench to the nut on the Joint #6 reduction gear unit. Insert the tool to the hole where the plug was, and then tighten the screw.

Hexagon socket head cap bolt: 1-M3×8 (with a plain washer)

Tightening torque: 2.5 N·m (25 kgf·cm)

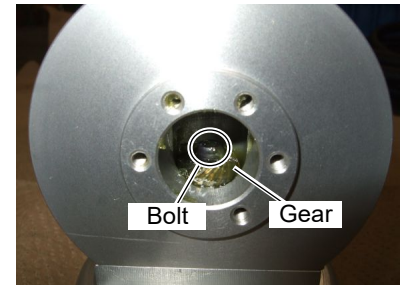

6. Install the Joint #6 reduction gear unit to the Arm #5.

Hexagon socket head cap bolts: 6-M3×28

Tightening torque: 2.5 N·m (25 kgf·cm)

There is a bearing on the back side of the flexspline. If you removed the bearing during the removal steps, install the bearing first and install the Joint #6 reduction gear unit to the Arm #5.



7. Install the Joint #6 flange.

Hexagon socket head cap bolts: 7-M3×6

Tightening torque: 2.5 N·m (25 kgf·cm)



8. Inject grease to the gear and insert the plug to the end.

Grease: SK-2

Grease volume: 2 g

9. Install the removed O-ring.

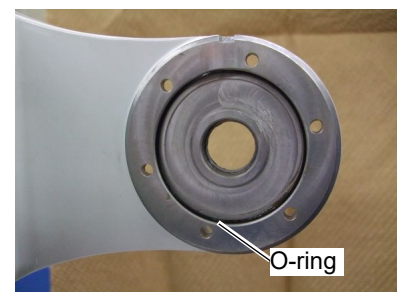

10. Install the Arm #5 unit to the Arm #4.

For details, refer to *Maintenance: 9.2 Joint #5 – Replacing the Motor*, Installation steps (13) through (25).

10.3 Joint #6 - Replacing the Timing Belt

	Name	Quantity	Note
Maintenance Parts	Joint #6 timing belt (324 mm)	1	1593701
Tools	Hexagonal wrench (width across flats: 3 mm)	1	For M3 hexagon socket head cap bolts
	Cross-point screwdriver	1	For covers
	Force gauge	1	For belt tension adjustment

Removal: Joint #6 Timing belt

1. Turn OFF the Controller power.
2. Remove the Arm #4 side cover.
For details, refer to *Maintenance: 3. Covers*.
3. Loosen the Joint #6 motor unit set screw.
Hexagon socket head cap bolt: 2-M4×15 (with a plain washer)
4. Remove the Joint #6 timing belt.

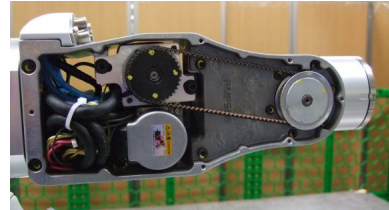

Installation: Joint #6 Timing belt

1. Place the Joint #6 timing belt around the pulley 1 and 2 of the Joint #6.
2. Secure the Joint #6 motor unit.
For details, refer to *Maintenance: 10.1 Joint #6 – Replacing the Motor*, Installation steps (5), (6), (8) and (9).

10.4 Joint #6 - Replacing the Electromagnetic Brake

	Name		Quantity	Note
Maintenance Parts	Joint #6 electromagnetic brake		1	1605913
Tools	Hexagonal wrench	width across flats: 1.5 mm	1	For M3 hexagon socket set screws
		width across flats: 2 mm	1	For M2.5 hexagon socket head cap bolts
		width across flats: 3 mm	1	For M4 hexagon socket head cap bolts
	Cross-point screwdriver		1	For covers
	Nippers		1	
Force gauge		1	For belt tension adjustment	

Removal: Joint #6 Electromagnetic brake

1. Remove the Joint #6 electromagnetic brake.
For details, refer to *Maintenance: 10.1 Joint #6 – Replacing the Motor*, Installation steps (1) through (7).

Installation: Joint #5 Electromagnetic brake

1. Mount the Joint #6 electromagnetic brake to the Joint #6 motor unit.
For details, refer to *Maintenance: 10.1 Joint #6 – Replacing the Motor*, Installation steps (2) through (9).

11. Replacing the Arm #5 O-ring

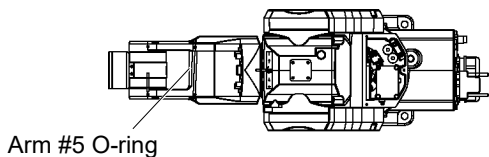

	Name	Quantity	Note
Maintenance Parts	O-ring (Arm #5)	1	1520374

Removal: Arm #5 O-ring

1. Turn ON the Controller power.
2. Move the Arm #5 to the angle where you can unplug the plug easily.
3. Turn OFF the Controller power.
4. Insert a screw to the plug.
5. While holding the screw, disconnect the plug.
6. Remove the O-ring from the plug.

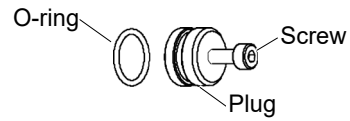
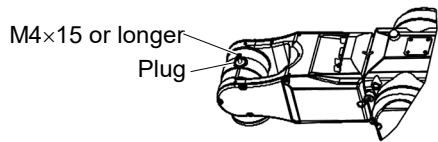
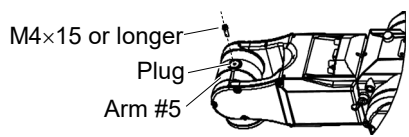

Installation: Arm #5 O-ring

1. Install the O-ring to the plug.
2. Insert the plug to the Arm #5.
Push the plug to the stopper at the end.
3. Remove the screw.
If you move the arm with the screw mounted, it may contact with the Manipulator body. Make sure to remove the screw.

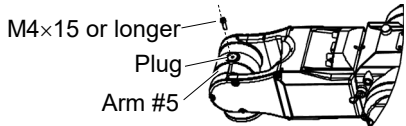
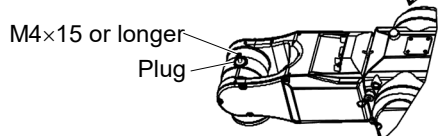
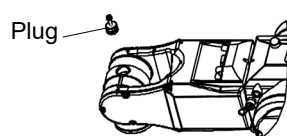
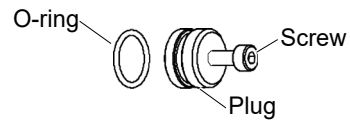

12. Replacing the Battery Unit



WARNING

- Do not connect or disconnect the motor connectors while the power to the robot system is turned ON. Connecting or disconnecting the motor connectors with the power ON is extremely hazardous and may result in serious bodily injury as the Manipulator may move abnormally, and also may result in electric shock and/or malfunction of the robot system.
- To shut off power to the robot system, disconnect the power plug from the power source. Be sure to connect the AC power cable to a power receptacle. DO NOT connect it directly to a factory power source.
- Before performing any replacement procedure, turn OFF the Controller and related equipment, and then disconnect the power plug from the power source. Performing any replacement procedure with the power ON is extremely hazardous and may result in electric shock and/or malfunction of the robot system.



WARNING

- Take meticulous care when handling the lithium battery. Improper handling of the lithium battery as mentioned below is extremely hazardous and may result in heat generation, leakage, explosion, or inflammation. It also may cause serious safety problems.
<Improper Handling>

Attempting to charge	Deforming by pressure
Disassembling	Short-circuit (Polarity; Positive/Negative)
Connecting batteries improperly	Heating (85 °C or more)
Exposing to fire	Soldering the terminal of the lithium battery directly
Forcing discharge	
- When disposing the battery, consult with the professional disposal services or comply with the local regulation. Make sure that the battery terminal is insulated, even for a used battery. If the terminal contacts with the other metals, it may short and result in heat generation, leakage, explosion, or inflammation.

In case of the low lithium battery power, the error to warn the voltage reduction occurs at the Controller startup (the software startup). All position data will be lost and you will need to calibrate all joints.

The life span of the lithium battery varies depending on the energizing hours and installation environment of the Controller. It is about 1.5 years as a rough guide (when the Controller is connected to power for 8 hours a day). When the Controller is not connected to power, the battery consumption will significantly increase compared to when the Controller is energized. If warnings of voltage reduction occur, replace the lithium metal battery even if it has not reached the above product life.



NOTE

For the EPSON RC+ 7.0 Ver. 7.2.x or later (firmware Ver.7.2.x.x or later), the recommended replacement time for the battery can be checked in the [Maintenance] dialog box of the EPSON RC+ 7.0.

For details, refer to the following manual.

Robot Controller RC700 / RC700-A Maintenance 6. Alarm

Maintenance 12. Replacing the Battery Unit

The battery may run out if it passes the recommended replacement time.

If no warnings of voltage reduction occur, the calibration for all joints is not necessary. You need to perform calibration if the position moves from the originals after replaced the battery.

Always use the lithium battery and battery board designated by us.

(Refer to *Maintenance: 14. Maintenance Parts List.*)

Be careful of the battery polarity to connect it correctly.

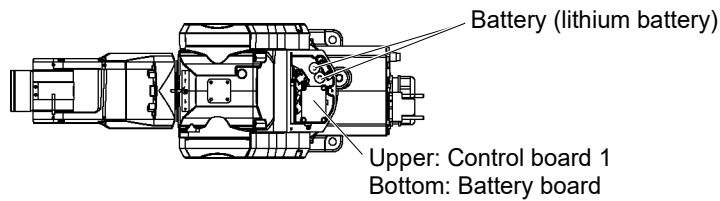

	Name		Quantity	Note
Maintenance Parts	Battery unit (Lithium battery)		1	1605912 (2 lithium batteries for replacement)
	Battery board		1	2177458
	Battery relay cable unit		1	1653173 (Reusable. See "Note" below)
Tools	Nippers		1	
	Cross-point screwdriver		1	For covers
	Hexagonal wrench	width across flats: 2.5 mm	1	For M3 hexagon socket head cap bolts
		width across flats: 3 mm	1	For M4 hexagon socket head cap bolts

Note: The battery relay cable unit is reusable. If the cable or the connector clip is broken during replacement of the cable unit and battery, replace the cable unit. For details on the replacement, refer to Removal step (10) and Installation step (55) in *Maintenance 4. Cable Unit.*

12.1 Replacing the Battery Unit (Lithium Battery)

1. Turn OFF the Controller power.
2. Remove the Arm #1 upper cover.
For details, refer to *Maintenance: 3. Covers*.
3. Loosen the screws fixing the L-shaped plate on the Arm #1 and remove the plate.

Hexagon socket head cap bolts: 2-M4×8

Be careful not to disconnect the battery connector.

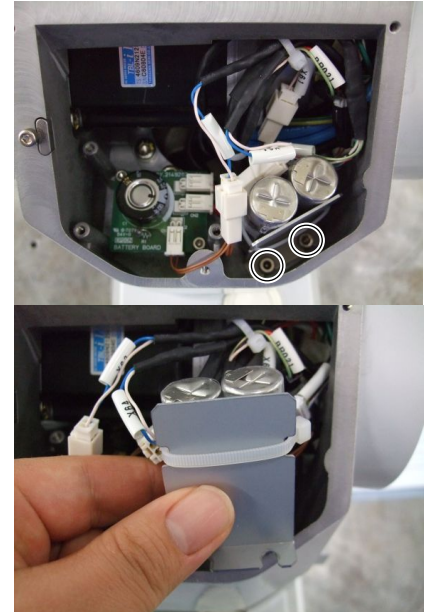

NOTE  If you removed all the batteries before connecting the new ones, the calibration data will be deleted and you will need to perform calibration. Follow the steps below to remove the lithium batteries.

4. Cut off the wire tie of the plate.
5. Disconnect the connector of one of two batteries. Then, connect the connector of the new battery.
6. Disconnect the connector of the other battery. Then, connect the connector of the new battery.



7. Bind two batteries to the plate using a wire tie.



Set the wire tie on the groove of the plate.



8. Fix the plate to the Arm #1.
Hexagon socket head cap bolts: 2-M4×8



9. Install the Arm #1 upper cover.
For details, refer to *Maintenance: 3. Covers*.
10. Turn ON the Controller power.
11. Check operation to see if the Manipulator's position and posture are out of position. Move the Manipulator to two or three points (poses) of the registered points.
12. If the Manipulator is out of position, calibrate all the joints and axes.
For details, refer to *Maintenance: 16. Calibration*.

12.2 Replacing the Battery Board

After parts have been replaced (motors, reduction gear units, brakes, timing belts, etc.), the Manipulator cannot perform positioning properly because a gap exists between the origin stored in each motor encoder and its corresponding origin stored in the Controller. Therefore, it is necessary to match these origins after replacing the parts.

The process of aligning the two origins is called “Calibration”.

Refer to *Maintenance 16. Calibration* and perform the calibration after the parts replacement.

Removal: Battery board

1. Turn OFF the Controller power.
2. Remove the Arm #1 upper cover.
For details, refer to *Maintenance: 3. Covers*.
3. Disconnect the connector from the control board 1.

Connector: GS01



4. Remove the control board 1.

Cross recessed head screws: 3-M3×8



5. Disconnect the three connectors from the battery board.

Connectors: 2 connectors for the batteries, CN3

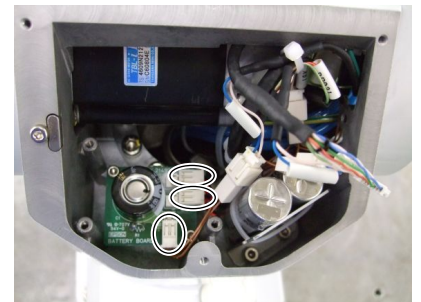

6. Remove the battery board fixed to the Arm #1.

Hexagon socket head cap bolts: 2-M3×8



Installation: Battery board

1. Install the battery board to the Arm #1.
Hexagon socket head cap bolts: 2-M3×8



2. Connect the connectors to the battery board.



3. Install the control board 1.
Cross recessed head screws: 3-M3×8

Be careful of the direction of the control board 1.
(See the photo.)



4. Install the connector to the control board 1.
Connector: GS01



5. Install the Arm #1 upper cover.
For details, refer to *Maintenance: 3. Covers*.
6. Turn ON the Controller power.
7. Check operation to see if the Manipulator's position and posture are out of position. Move the Manipulator to two or three points (poses) of the registered points.
8. Perform the calibration.
For details, refer to *Maintenance: 16. Calibration*.

13. Replacing the Control Board



- Do not connect or disconnect the motor connectors while the power to the robot system is turned ON. Connecting or disconnecting the motor connectors with the power ON is extremely hazardous and may result in serious bodily injury as the Manipulator may move abnormally, and also may result in electric shock and/or malfunction of the robot system.
- To shut off power to the robot system, disconnect the power plug from the power source. Be sure to connect the AC power cable to a power receptacle. DO NOT connect it directly to a factory power source.
- Before performing any replacement procedure, turn OFF the Controller and related equipment, and then disconnect the power plug from the power source. Performing any replacement procedure with the power ON is extremely hazardous and may result in electric shock and/or malfunction of the robot system.

Always use the control board designated by us.

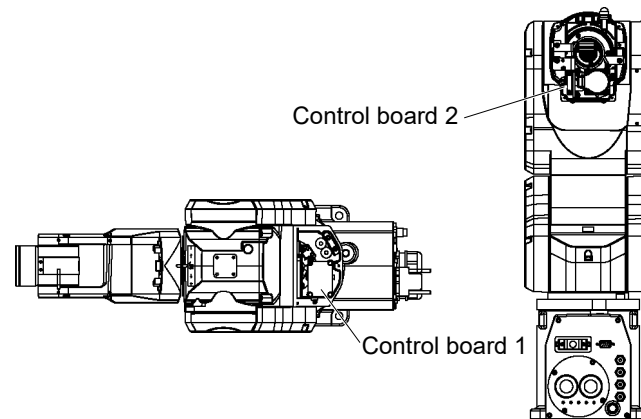

	Name	Quantity	Note
Maintenance Parts	Control board (1, 2)	1	2138032
Tools	Nippers	1	
	Cross-point screwdriver	1	For control boards
	Hexagonal wrench (width across flats: 2.5 mm)	1	For M3 hexagon socket head cap bolts
	Hexagonal wrench (width across flats: 3 mm)	1	For M4 hexagon socket head cap bolts

13.1 Replacing the Control Board 1

Removal: Control board 1

1. Follow *Maintenance: 12.1 Replacing the Battery Unit (Lithium Battery)* steps (1) through (4).

Installation: Control board 1

1. Follow *Maintenance: 12.1 Replacing the Battery Unit (Lithium Battery)* steps (11) through (14).

13.2 Replacing the Control Board 2

Removal: Control board 2

1. Turn OFF the Controller power.
2. Remove the Arm #3 head cover.
For details, refer to *Maintenance: 3. Covers*.
3. Remove the ground wire fixed to the plate.
Hexagon socket head cap bolts: 2-M4×5
4. Remove the connector connected to the control board 2.
Connector: GS02
5. Remove the plate fixed to the Arm #3.
Hexagon socket head cap bolt: M4×10
Hexagon socket head cap bolt: M3×8
6. Remove the control board 2 fixed to the plate.
Cross recessed head screw: 4-M3×8

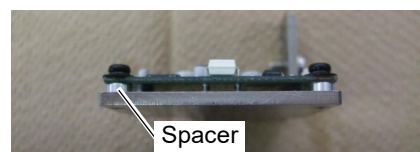
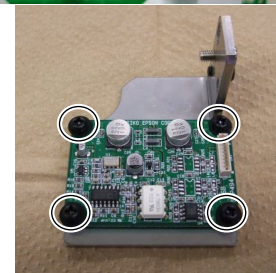
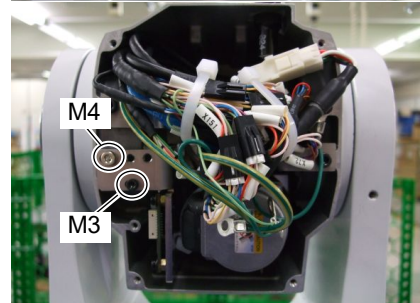
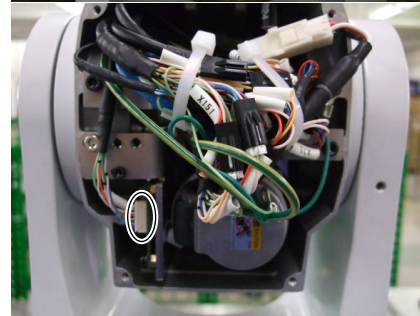
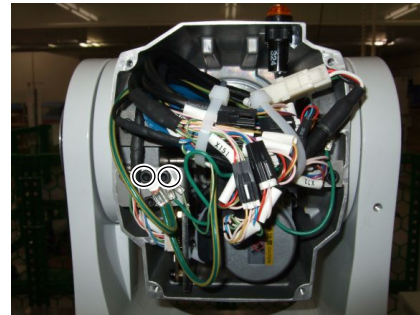

There is a spacer between the plate and the control board 2.
The spacer will be used again. Be careful not to lose it.

Spacer: 4 spacers

Installation: Control board 2

1. Install the control board 2 to the plate.

Cross recessed head screws: 4-M3×8

Insert the spacer between the plate and the control board 2.

Be careful of the direction of the control board 2.

(See the photo.)

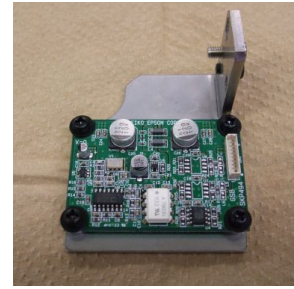

2. Install the plate with the control board 2 to the Arm #3.

Hexagon socket head cap bolt: M4×10

Hexagon socket head cap bolt: M3×8

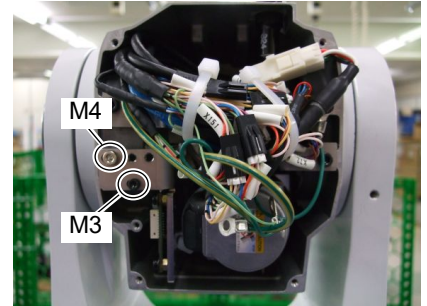

3. Connect the connector to the control board 2.

Connector: GS02

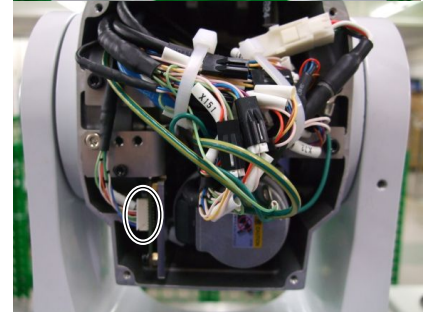

4. Install the removed ground wire to the plate.

Hexagon socket head cap bolt: 2-M4×5

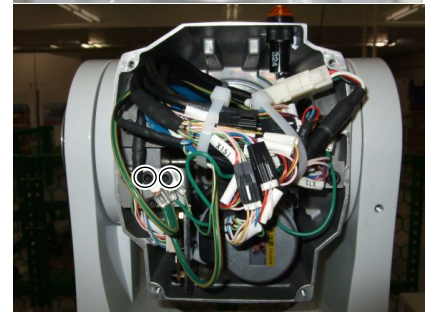

5. Install the Arm #3 head cover.

For details, refer to *Maintenance: 3. Covers*.

6. Turn ON the Controller power.
7. Check operation to see if the Manipulator's position and posture are out of position.
Move the Manipulator to two or three points (poses) of the registered points.
8. If the Manipulator is out of position, calibrate all the joints and axes.
For details, refer to *Maintenance: 16. Calibration*.

14. Replacing the LED Lamp



- Do not connect or disconnect the motor connectors while the power to the robot system is turned ON. Connecting or disconnecting the motor connectors with the power ON is extremely hazardous and may result in serious bodily injury as the Manipulator may move abnormally, and also may result in electric shock and/or malfunction of the robot system.
- To shut off power to the robot system, disconnect the power plug from the power source. Be sure to connect the AC power cable to a power receptacle. DO NOT connect it directly to a factory power source.
- Before performing any replacement procedure, turn OFF the Controller and related equipment, and then disconnect the power plug from the power source. Performing any replacement procedure with the power ON is extremely hazardous and may result in electric shock and/or malfunction of the robot system.

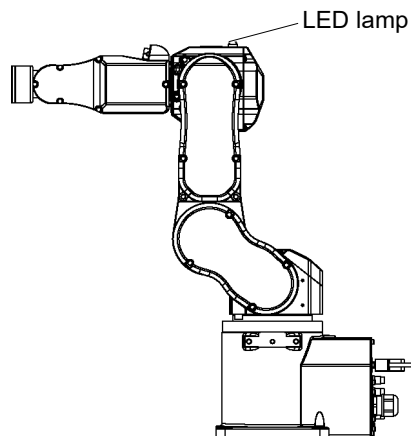

	Name	Quantity	Note
Maintenance Parts	LED lamp	1	1605919
Tools	Cross-point screwdriver	1	For covers

Removal: LED lamp

1. Turn OFF the Controller power.
2. Remove the Arm #3 head cover.
For details, refer to *Maintenance: 3. Covers*.
3. Remove the connector connected to the LED lamp.
The connector for the LED lamp (LED) is under the Arm #3 head cover.

Connector: LED

4. Remove the LED lamp from the Arm #3.

Turn the resin nut securing the LED lamp in the Arm #3 counter-clockwise.

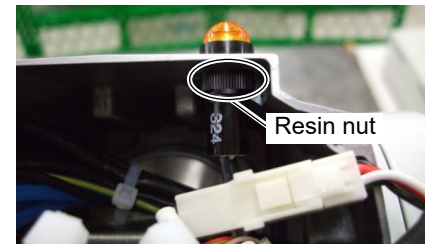



Installation: LED lamp

1. Install the LED lamp to the Arm #3.
Detach the resin nut from the LED lamp and pass the lamp through the Arm #3. Turn the nut clockwise from the inside of the Arm #3 and secure the lamp to the Arm #3.
2. Connect the following connectors.
Connector: LED
3. Install the Arm #3 head cover.
For details, refer to *Maintenance: 3. Covers*.

15. Replacing the M/C Cable

Each motor is fed power by the battery for backup. Therefore, position data is held even after turning OFF the Controller. The position data will be lost when the cable connector connected to the battery is disconnected. And the EPSON RC+ will display the error message of encoder alarm occurrence when the Controller is turned ON.

 WARNING	<ul style="list-style-type: none"> ■ Do not connect or disconnect the motor connectors while the power to the robot system is turned ON. Connecting or disconnecting the motor connectors with the power ON is extremely hazardous and may result in serious bodily injury as the Manipulator may move abnormally, and also may result in electric shock and/or malfunction of the robot system. ■ To shut off power to the robot system, disconnect the power plug from the power source. Be sure to connect the AC power cable to a power receptacle. DO NOT connect it directly to a factory power source. ■ Before performing any replacement procedure, turn OFF the Controller and related equipment, and then disconnect the power plug from the power source. Performing any replacement procedure with the power ON is extremely hazardous and may result in electric shock and/or malfunction of the robot system.
--	---

 CAUTION	<ul style="list-style-type: none"> ■ When disconnecting the connectors during the replacement of the cable unit, be sure to reconnect the connectors to their proper positions by referring to the connector pin assignments. Improper connection of the connectors may result in improper function of the robot system. For details on the connections, refer to the <i>Maintenance 4.2 Connector Pin Assignments</i>. ■ When installing the cover, be careful not to allow the cables to interfere with the cover mounting and do not bend these cables forcibly to push them into the cover. Unnecessary strain on cables may result in damage to the cables, disconnection, and/or contact failure. These are extremely hazardous and may result in electric shock and/or improper function of the robot system. When routing the cables, check the cable locations after removing the cover. Be sure to place the cables back to their original locations. ■ Be sure to connect the cables properly. Do not allow unnecessary strain on the cables. (Do not put heavy objects on the cables. Do not bend or pull the cables forcibly.) Unnecessary strain on cables may result in damage to the cables, disconnection, and/or contact failure. These are extremely hazardous and may result in electric shock and/or improper function of the robot system.
--	---

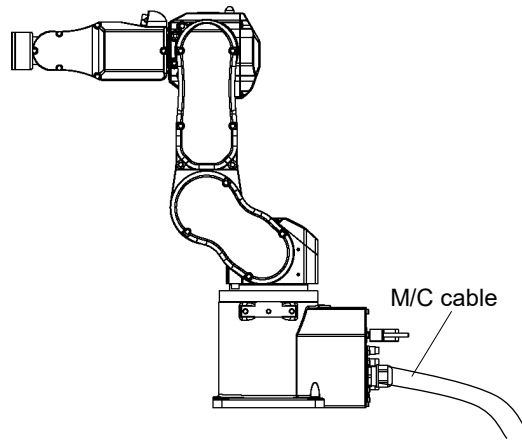

NOTE  Make sure to calibrate after the cable replacement.
For details, refer to *Maintenance: 16. Calibration.*

	Name		Quantity	Note		
Maintenance Parts	M/C cable	3 m	Straight	1	1605915	
			L-shaped	1	2169647	
		5 m	Straight	1	1605916	
			L-shaped	1	2169648	
		10 m	Straight	1	1605917	
			L-shaped	1	2169649	
		15 m	Straight	1	2185605	
			L-shaped	1	2185614	
		20 m	Straight	1	2185495	
			L-shaped	1	2185615	
		M/C cable (UL specification)	3 m	Straight	1	2182509
			5 m	Straight	1	2182510
10 m	Straight		1	2182511		
Tools	Hexagonal wrench (width across flats: 3 mm)		1	For M4 hexagon socket head cap bolts		

Removal: M/C cable

1. Turn OFF the Controller power.
2. Disconnect the following connectors from the Controller.
 - Power cable connector
 - Signal cable connector

3. Remove the connector sub plate.
 - For details, refer to *Maintenance: 3. Covers*.

NOTE



Do not pull the sub plate forcibly.

Do not disconnect the M/C cable from the connector sub plate.

4. Remove the connectors.

Connectors: X11, X12, X13, X14, X15, X16, XGND*, BR010, BR020, BR030, BR040, BR050, BR060
X010, X020, X030, X040, X050, X060, LED, GS01, GS02

* No XGND connector for UL specification.

NOTE



Each connector is numbered. Each connector has a different shape.

Do not disconnect the battery connector (BT1*). Otherwise, you will need to calibrate.

Installation: M/C cable

1. Connect the connectors of the new M/C cable to these of the cable unit.
 - Connect the connectors with the same number.
2. Install the connector sub plate to the connector plate.
 - For details, refer to *Maintenance: 3. Covers*.
3. Connect the following connectors to the Controller.
 - Power cable connector
 - Signal cable connector
4. Turn ON the Controller power.
5. Check operation to see if the Manipulator's position and posture are out of position.
 - Move the Manipulator to two or three points (poses) of the registered points.
6. If the battery connector (BT1*) was disconnected, perform the calibration.
 - For details, refer to *Maintenance: 16. Calibration*.
7. If the Manipulator is out of position, calibrate all the joints and axes.
 - For details, refer to *Maintenance: 16. Calibration*.

16. Calibration

16.1. Overview

After parts have been replaced (motors, reduction gear units, timing belts, etc.), the Manipulator cannot perform positioning properly because a gap exists between the origin stored in each motor encoder and its corresponding origin stored in the Controller.

Therefore, it is necessary to match these origins after replacing the parts.

The process of aligning the two origins is called “Calibration”. Note that calibration is not the same as teaching*.

* “Teaching” means to teach the Controller coordinate points (including poses) anywhere in the operating area of the Manipulator.

 WARNING	<ul style="list-style-type: none"> ■ To ensure safety, a safeguard must be installed for the robot system. For details on the safeguard, refer to the <i>Installation and Design Precautions</i> in the <i>Safety</i> chapter of the <i>EPSON RC+ User's Guide</i>. ■ Before operating the robot system, make sure that no one is inside the safeguarded area. The robot system can be operated in the mode for teaching even when someone is inside the safeguarded area. The motion of the Manipulator is always in restricted (low speeds and low power) status to secure the safety of an operator. However, operating the robot system while someone is inside the safeguarded area is extremely hazardous and may result in serious safety problems in case that the Manipulator moves unexpectedly.
---	--

In EPSON RC+, a coordinate point including the arm pose is defined as “point” and its data is called “point data”.

There are two methods to move the Manipulator during calibration.

- Releasing the electromagnetic brake and moving the arms manually.

For details, refer to the *Setup & Operation 1.5 How to Move Arms with the Electromagnetic Brake*.

- Moving the Manipulator using Jog & Teach.

Moving the Manipulator while releasing the electromagnetic brake involves risk as described below.

It is recommended to move the Manipulator using Jog & Teach.

 CAUTION	<ul style="list-style-type: none"> ■ Normally, release the brake of joints one by one. Take extra care if you need to release the brakes of two or more joints simultaneously. Releasing the brakes of two or more joints simultaneously may cause hands and fingers to be caught and/or equipment damage to or malfunction of the Manipulator as the arms of the Manipulator may move in unexpected directions. ■ Be careful of the arm falling when releasing the brake. While the brake is being released, the Manipulator's arm falls by its own weight. The arm falling may cause hands and fingers to be caught and/or may cause equipment damage to or malfunction of the Manipulator.
---	---

For details on Jog & Teach, refer to *EPSON RC+ User's Guide 5.11.1 Robot Manager Command Tools: Robot Manager: Jog and Teach Page*.



- For details about the basic pose, refer to *Setup & Operation 3.7 Checking the Basic orientation*.
- Whenever possible, calibrate one joint at a time. (Also, replace parts of one joint at a time whenever possible.) If you calibrate the origins for multiple joints simultaneously, it will be more difficult to verify their origins and obtain the origin correct positions. However, joint #5 cannot be calibrated alone due to the structure of the Manipulator. Make sure you calibrate joint #5 and #6 at the same time.

Calibration Flowchart

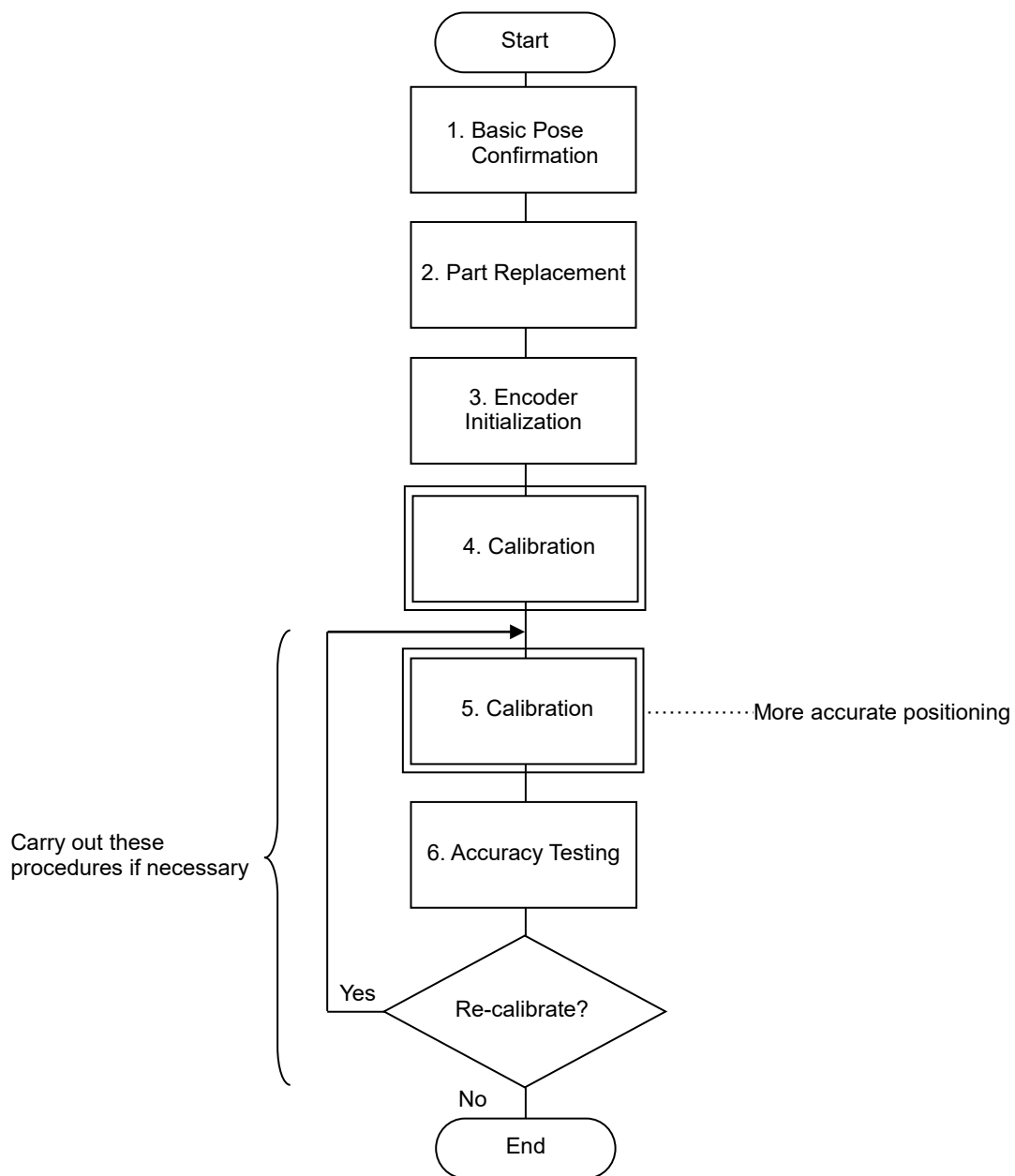

16.2. Calibration Procedure

Command Input

Command execution is required in some calibration procedures.

Select the EPSON RC+ menu-[Tools]-[Command Window].

This step is omitted in the calibration procedures.

Jog Motion

Setting of the jog motion is required in some calibration procedures.

Select EPSON RC+ menu-[Tools]-[Robot Manager] and select the [Jog & Teach] page.

The panel, window, and page above are indicated as [Jog & Teach] in the calibration procedures.

Follow steps 1 to 6 to calibrate the Manipulator.

1. Basic Pose Confirmation

Pose data (Point data) prior to the part replacement (motors, reduction gear unit, or belt) is necessary for the calibration.

Verify the recorded pulse values of the basic pose obtained in the *Setup & Operation 3.7 Checking the Basic orientation*.

2. Part Replacement

Replace parts as instructed in this manual.

Be careful not to injure yourself or damage parts during part replacement.

3. Encoder Initialization

Turn ON the Controller while all joints are in the motion range.

The error message “Encoder alarm has occurred. Check robot battery. EPSON RC+ must be restarted.” will be displayed.

Initialize the encoder at the current position and reset the error.

Initialize the encoder using one of the following procedures.

Execute the following command at the [Monitor Window].

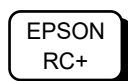

>Encreset [The joint number (1 to 6) of the encoder to be reset]

Select EPSON RC+ menu-[Tools]-[Controller], then click <Reset Controller>.

After resetting the error, the motor encoder of the joint whose parts have been replaced will be initialized.

Set the jog mode to “Joint” in [Jog & Teach] and operate the Manipulator in jog motion to match the home position marks (0 pulse position) of the joint accurately.

When the joint cannot move to the home position, operate the Manipulator to match the tram mark placed in *Setup & Operation 3.7 Checking the Basic Orientation* as accurate as possible.

Initialize the encoder when the joint matches the home position or the tram mark.

For the encoder initialization, refer to the procedure indicated above.



When the origin of the Joint #5 is calibrated, the Joint #6 will be out of position. (Due to the structure of the Manipulator, any offset in the position of the Joint #5 affects the Joint #6.)

Calibrate the origin of the Joint #6 together when calibrating the Joint #5.

4. Calibration

Position of grooves for calibration

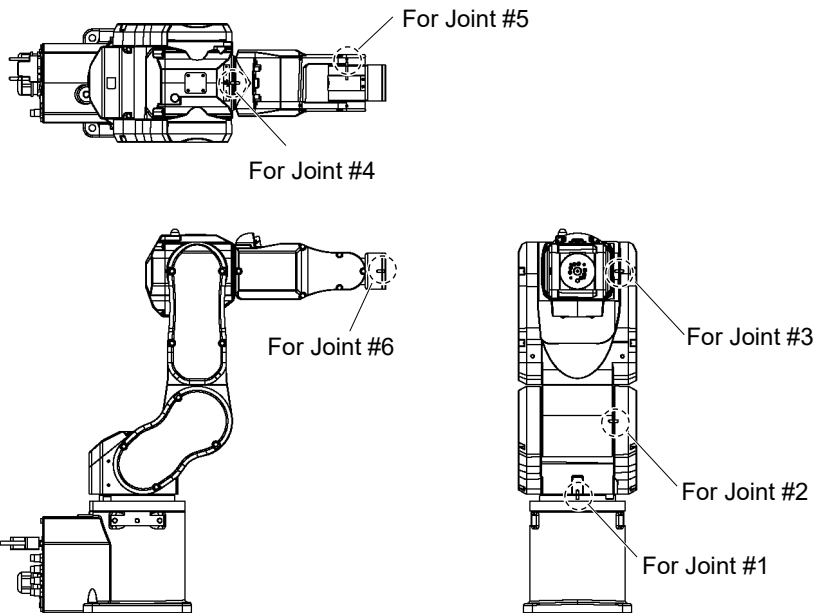

Position of the calibration key



The key is secured to the inside of the Arm #1 center cover using M4 screw.

Hexagon socket head cap bolts: M3×6
Be sure to put the key back to the original position after use.

4-1 Prepare the calibration key.

A calibration key is secured inside the Arm #1 center cover using the M4 screw.
Be careful not to lose the screw.

4-2 Move the arm you want to calibrate to the position of the calibration groove.

EPSON
RC+

Select menu-[Tool]-[Robot Manager]-[Jog & Teach] panel to move the Manipulator.

If an error occurs after replacing the motor and you cannot use the [Jog & Teach] panel or “Brake OFF, *” does not work (* is an axis number to calibrate.), go through the steps (4) and (5) now.

Then, [Jog & Teach] panel and “Brake OFF, *” will be available. Move the arm you want to calibrate to the position of the calibration groove and go on to the step 4-3.

4-3 Set the calibration key to the calibration groove (the grooves for Joints #1 to #6).

At this point, if the key cannot be set completely, the arm(s) is not in the origin. Move the arm until the key can be set completely.

The key will be broken if you move any arm with the key in the groove.

Do not move arm(s) once its position is fixed.

4-4 Reset the encoder.

EPSON
RC+

Execute one of the following commands to reset the encoder of the joint you want to calibrate from the menu-[Tool]-[Command Window].

```
Joint #1 >Encreset 1
Joint #2 >Encreset 2
Joint #3 >Encreset 3
Joint #4 >Encreset 4
Joint #5 >Encreset 5, 6
Joint #6 >Encreset 6
```

4-5 Reboot the Controller.

EPSON
RC+

Click EPSON RC+ menu-[Tool]-[Controller]-<Reset Controller>.

4-6 Input the command in the Command window and execute it.

EPSON
RC+

Execute one of the following commands to reset the encoder of the joint you want to calibrate from the menu-[Tool]-[Command Window].

```
>calpls 0,0,0,0,0,0
* Manipulator does not move.
```

4-7 Perform the calibration.

EPSON
RC+

Execute one of the following commands to reset the encoder of the joint you want to calibrate from the menu-[Tool]-[Command Window].

```
Joint #1 >calib 1  
Joint #2 >calib 2  
Joint #3 >calib 3  
Joint #4 >calib 4  
Joint #5 >calib 5, 6  
Joint #6 >calib 6
```

Move the arm to several points to check if the arm moves to the original positions properly.

Teach points if fine adjustment is necessary.

4-8 All joints are calibrated.

Put the calibration key back to the original position in the Arm #1 and secure it with the screw.

Hexagon socket head cap bolt: 1-M3×6



4-9 Mount the Arm #1 cover.

For details, refer to *Maintenance: 3. Covers*.

5. Calibration (More accurate positioning)

EPSON
RC+

Move the Manipulator to the selected point data by jogging in [Jog & Teach].

Move the joint* which is not calibrated to the specified point by motion command.

*When the Joint #5 is being calibrated, move the Joints #1 - #4 to the home positions.

For example, when the selected point data is “P1”, execute “Motor On” in [Control Panel] and execute “Go P1” in [Jog & Teach].

Position the calibrating joint* to the selected point data position accurately by jog command.

* When the Joint #5 is being calibrated, move the Joint #5 and #6 to the home positions.

Select the “Joint” jog mode from [Jog & Teach] to operate in the jog motion.

Enter the command below in the command window and execute it.

Execute the command below in the menu -[Tools]-[Command Window].

```
>calpls ppls(P1,1), ppls(P1,2), ppls(P1,3), ppls(P1,4),  
ppls(P1,5), ppls(P1,6)
```

*The Manipulator will not move.

Perform the calibration. Input one of the following commands according to the joint being calibrated.

```
Joint #1 : >calib 1  
Joint #2 : >calib 2  
Joint #3 : >calib 3  
Joint #4 : >calib 4  
Joint #5 : >calib 5,6  
Joint #6 : >calib 6
```

6. Accuracy Testing

Move the Manipulator to a different pose (point) to verify whether it moves back to the original position. If accuracy is inadequate, it is necessary to re-calibrate the origin using a different pose (point). You must set the pose (point) again if the Manipulator does not move back to the original position after re-calibration.

17. Maintenance Parts List

Name		Code	Old Code	Note	Reference in Maintenance	Overhaul **	
Motor	Joint #1, #2	2150748	R13N807011	400 W	5.1, 6.1	✓	
	Joint #3	2209414	–	150 W + Electromagnetic brake	7.1	✓	
	Joint #4, #5, #6	2149265	R13N807031	50 W	8.1, 9.1, 10.1	✓	
Reduction gear unit *	Joint #1	1687022	R13N810041		5.2	✓	
	Joint #2	1687023	R13N810051		6.2	✓	
	Joint #3	1593859	R13N810061		7.2	✓	
	Joint #4	1533648	R13B010023		8.2	✓	
	Joint #5	1539260	R13B010024		9.2	✓	
	Joint #6	1539261	R13B010025		10.2	✓	
Bevel gear		1667824	R13B031603			✓	
Electromagnetic brake	Joint #1, #2	1605914	R13N835021		5.4, 6.4	✓	
	Joint #4, #5, #6	1605913	R13N835011		8.4, 9.4, 10.4	✓	
Timing belt	Joint #1	C4-A601**	1520394	R13B030220	Width 10 mm	5.3	✓
		C4-A901**	1593695	R13N832031			
	Joint #2	C4-A601**	1520354	R13B030221	Width 10 mm	6.3	✓
		C4-A901**	1593696	R13N832041			
	Joint #3	C4-A601**	1593697	R13N832081	Width 7 mm	7.3	✓
		C4-A901**	1593698	R13N832091			
	Joint #4		1593699	R13N832051	Width 6 mm	8.3	✓
	Joint #5		1599367	R13N832061	Width 315 mm	9.3	✓
Joint #6		1593701	R13N832071	6 mm 324 mm	10.3	✓	

* Reduction Gear Unit: A reduction gear unit consists of the following three parts. When replacing the reduction gear unit, be sure to replace these parts all together as a set.

Waveform generator

The waveform generator consists of an ellipsoidal cam and ball bearings on outer circumference. The inner ring of the bearings is secured to the cam, while the outer ring is capable of flexible deformation through the ball bearings.

Flexspline

A thin, elastic, cup-shaped metal body with gear teeth around the outer circumference of the opening.

Circular spline

A rigid, ring-shaped body with gear teeth on the inner circumference.

The circular spline has two more teeth than the flexspline does.

The splines are greased. Be sure to keep the grease from being attaching to the clothes.

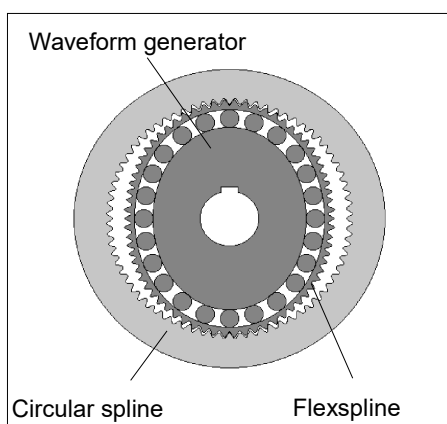

**** Overhaul**

As a rough indication, perform the overhaul (parts replacement) before reaching 20,000 operation hours of the Manipulator. The operation hours can be checked in [Controller Status Viewer] dialog box - [Motor On Hours].

For details, refer to *Maintenance 2.2 Overhaul (Parts Replacement)*.

Name		Code	Old Code	Note	Reference in <i>Maintenance</i>
Battery board		2177458	R13N84C011		12.1
Battery unit (Lithium battery)		1605912	R13N860011	(2 lithium batteries for replacement)	12.1
Seal	Joint #4	1213320	R13A031200100		8.2
Grease ***	Joint #1, #2, #3, #4 : SK-1A	—	—	For purchasing grease, please contact the supplier of your region.	2.3, 5.2, 6.2, 7.2, 8.2
	Bevel gear Joint #5, #6 : SK-2	—	—		2.3, 9.2, 10.2
	Cable : GPL-224	—	—		4.1
Oil seal	Joint #1	1480855	R13B031224		
	Joint #6	1520625	R13B031248		
Grease seal	Joint #1, #2	1213292	R13B031249		
	Joint #3	1520361	R13B031250		
Control board 1, 2	Arm #1, #3	2138032	R13B040502		13
Noise dissipative diode	Joint #1, #2, #3	2167709	R13N823011		5.4, 6.4, 7.1
O ring	Joint #1	1480857	R13B031223		5.2
	Joint #2	1510528	R13B031242		6.2
	Joint #3	1520370	R13B031243		7.2
	Joint #4	1520372	R13B031244		8.2
	Arm #3, #4	1520371	R13B031245		
	Arm #5	1520374	R13B031247	For plug	11
LED lamp		1605919	R13N830011		14

***** Regarding purchase of grease**

Due to the chemicals regulations of individual countries (the UN GHS), we are requesting our customers to purchase grease required for maintenance from the manufacturers listed in the table below as of April 2015.

Regarding purchase of grease, please contact the following manufacturers. If there is anything unclear, please contact the supplier of your region.

Product name	Manufacturer	URL
Harmonic Grease SK-1A Harmonic Grease SK-2	Harmonic Drive Systems Inc.	http://www.harmonicdrive.net/
Krytox®GPL-224	DuPont	http://www2.dupont.com/Our_Company/en_US/worldwide/us_country.html

Maintenance 17. Maintenance Parts List

Name		Code	Old Code	Note	Reference in Maintenance		
M/C cable	3 m	Straight	1605915	R13N824011	15		
		L-shaped	2169647	R13NZ910EW			
	5 m	Straight	1605916	R13N824021			
		L-shaped	2169648	R13NZ910EX			
	10 m	Straight	1605917	R13N824031			
		L-shaped	2169649	R13NZ910EY			
	15 m	Straight	2185605	–			
		L-shaped	2185614	–			
	20 m	Straight	2185495	–			
		L-shaped	2185615	–			
	M/C cable (UL specification)	3 m	Straight	2182509		–	
		5 m	Straight	2182510		–	
10 m		Straight	2182511	–			
M/C power cable	3 m	Straight	2155584	R13N824041			
		L-shaped	2169357	R13NZ910EZ			
	5 m	Straight	2150707	R13N824051			
		L-shaped	2169358	R13NZ910F1			
	10 m	Straight	2155586	R13N824061			
		L-shaped	2169359	R13NZ910F2			
	15 m	Straight	2185612	–			
		L-shaped	2185620	–			
	20 m	Straight	2185496	–			
		L-shaped	2185621	–			
M/C power cable (UL specification)	3 m	Straight	2181813	–			
	5 m	Straight	2181914	–			
	10 m	Straight	2181915	–			
M/C signal cable	3 m		2150712	R13N827011			
	5 m		2150713	R13N827021			
	10 m		2150714	R13N827031			
	15 m		2185613	–			
	20 m		2185497	–			
Cable Unit	C4-A601**		2149411	R13N820011			
	C4-A901**		2155583	R13N820021			
	C4-A601**-UL		2182507	–			
	C4-A901**-UL		2182508	–			
Battery relay cable unit			1653173	–			
Radiation Sheet		Joint #2	1549699	R13B031905	6.1		
Cover	Arm #1	Center cover	2165173	R13N834011	3		
		Side cover	2165174	R13N834021			
	Arm #2	Side cover	2165175	R13N834031			
	Arm #3	Head cover	2165176	R13N834041			
	Arm #4	Side cover (right)	2165177	R13N834051			
		Side cover (left)	2165178	R13N834061			
	Arm #1	Center cover	1658607	R13N834131		Plated 3	
		Side cover	2165179	R13N834141			
	Arm #2	Side cover	2165180	R13N834151			
	Arm #3	Head cover	2165181	R13N834161			
	Arm #4	Side cover (right)	2165182	R13N834171			
		Side cover (left)	2165183	R13N834181			

18. Option Parts List

Name	Code	Old Code	Note	Reference in <i>Setup & Operation</i>
Brake release unit (with cable and short connector)	R12NZ9006F	R12B120805	For Europe	6.1
	R12NZ900JE	R12B120806	For U.S. & Japan	
Brake release unit (Main unit only)	R12NZ900M2	R12B120803	For Europe	
	R12NZ900KV	R12B120804	For U.S. & Japan	
Camera plate unit	R12NZ9003F	R12B031922		6.2
PS compatible plate	R12NZ9003G	R12B031923		6.3
Base side angled fitting	R12NZ900HF	R12B031924		6.4
Base side fitting	R12NZ9003H	R12B031925		6.5
PS Compatible Plate (Base Adapter)	R12NZ900A5	R12N73L021		6.6
Adjustable Mechanical Stop	R12NZ900L1	R12N73L011		6.7

