

# EPSON

EPSON RC+ 7.0 Option

*Part Feeding 7.0*

*IF-380 & IF-530*

Rev.3

EM208S4397F

EPSON RC+ 7.0 Option Part Feeding 7.0 IF-380 & IF-530 Rev.3

EPSON RC+ 7.0 Option

**Part Feeding 7.0 IF-380 & IF-530**

Rev.3

Copyright © 2019-2020 SEIKO EPSON CORPORATION. All rights reserved.

## FOREWORD

Thank you for purchasing our robot system.

This manual contains the information necessary for the correct use of the EPSON RC+ PartFeeding option.

Please carefully read this manual and other related manuals before installing the robot system.

Keep this manual handy for easy access at all times.

## WARRANTY

The robot system and its optional parts are shipped to our customers only after being subjected to the strictest quality controls, tests, and inspections to certify its compliance with our high performance standards.

Product malfunctions resulting from normal handling or operation will be repaired free of charge during the normal warranty period. (Please contact the supplier of your region for warranty period information.)

However, customers will be charged for repairs in the following cases (even if they occur during the warranty period):

1. Damage or malfunction caused by improper use which is not described in the manual, or careless use.
2. Malfunctions caused by customers' unauthorized disassembly.
3. Damage due to improper adjustments or unauthorized repair attempts.
4. Damage caused by natural disasters such as earthquake, flood, etc.

Warnings, Dangers, Usage:

1. If the robot system associated equipment is used outside of the usage conditions and product specifications described in the manuals, this warranty is void.
2. If you do not follow the WARNINGS and DANGERS in this manual, we cannot be responsible for any malfunction or accident, even if the result is injury or death.
3. We cannot foresee all possible dangers and consequences. Therefore, this manual cannot warn the user of all possible hazards.

## TRADEMARKS

Microsoft, Windows, Windows logo, Visual Basic, and Visual C++ are either registered trademarks or trademarks of Microsoft Corporation in the United States and/or other countries. Other brand and product names are trademarks or registered trademarks of the respective holders.

## TRADEMARK NOTATION IN THIS MANUAL

Microsoft® Windows® 8 Operating system

Microsoft® Windows® 10 Operating system

Throughout this manual, Windows 8 and Windows 10 refer to above respective operating systems. In some cases, Windows refers generically to Windows 8 and Windows 10.

## NOTICE

No part of this manual may be copied or reproduced without authorization.

The contents of this manual are subject to change without notice.

Please notify us if you should find any errors in this manual or if you have any comments regarding its contents.

## MANUFACTURER

**SEIKO EPSON CORPORATION**

## CONTACT INFORMATION

Contact information is described in “SUPPLIERS” in the first pages of the following manual:

*Robot System Safety and Installation Read this manual first*



## Hardware (IF-380 & IF-530)

<b>1. Introduction</b>	<b>3</b>
1.1 Overview .....	3
1.2 Safety precautions .....	4
1.2.1 General safety precaution .....	4
1.2.2 Danger.....	5
1.3 Warranty information.....	6
<b>2. Description</b>	<b>7</b>
2.1 First glimpse of product.....	7
2.2 General characteristics .....	8
2.2.1 Technical features.....	8
2.2.2 Overall dimensions.....	9
2.2.3 Visual signals .....	10
2.2.4 Maximum permissible external force on the platform .....	11
2.2.5 Permissible platform weight .....	11
2.2.6 Maximum plate displacement .....	12
2.2.7 Plate Z repeatability .....	12
2.2.8 Work surface .....	12
2.3 Electrical interfaces.....	13
2.3.1 Overview .....	13
2.3.2 Power connection.....	14
2.3.3 Fuse.....	16
2.3.4 Communication .....	16
2.3.5 Digital output for hoppers 1 and 2.....	17
2.3.6 Purge Connector .....	17
2.4 Mechanical Interfaces .....	18
2.4.1 Mounting the IF-380 & IF-530 .....	18
2.5 Accessories and Optional modules .....	19
2.5.1 Platform .....	19
2.5.2 Backlight.....	20
2.5.3 Hopper.....	21
<b>3. Transportation, handling, and installation</b>	<b>25</b>
3.1 Packaging of the product, transportation and handling .....	25
3.2 Unpacking instructions.....	25
3.3 Installation and storage environment.....	26
3.3.1 Installation environment .....	26
3.3.2 Storage environment.....	26
<b>4. Maintenance and component replacement</b>	<b>27</b>
4.1 Safety precautions .....	27

4.1.1	General safety precautions.....	27
4.1.2	Specific warnings .....	27
4.2	Maintenance .....	28
4.2.1	Periodic maintenance schedule.....	28
4.2.2	Remove the platform module.....	29
4.2.3	Control in purge configuration.....	31
4.2.4	Checking and cleaning of the platform .....	32
4.2.5	Replacing the ball joints .....	32
4.3	Component replacement .....	35
4.3.1	Exchanging / installing the backlight.....	35
4.3.2	Recover IP address using default IP address .....	40



# Hardware (IF-380 & IF-530)







# 1. Introduction

## 1.1 Overview

The following document is the property of Epson and may not be copied or circulated without permission. The information contained in this document is subject to change without notice for the purpose of product improvement. Before operating your product, please read this document in order to ensure correct use of the product. Nevertheless, if you meet difficulties during operation or maintenance, please, feel free to contact the supplier of your region.

In this manual, the safety precautions that you must follow are classified as: “Danger”, “Warning” and “NOTE”; the following symbols are used:



 DANGER	Failure to observe the instruction may result in serious injury.
 DANGER	Failure to observe the instruction may result in electrocution or serious injury due to electric shock
 WARNING	Failure to observe the instruction may result in injury or property damage.

NOTE 	The user should read this information carefully to ensure the correct use of the product, although failure to do so would not result in injury.
---	---



REFER TO ...

For more information on a specific subject, the reader should read another manual, or refer to other paragraph.

 WARNING	Epson shall not be liable whatsoever for any loss or damage arising from a failure to observe the items specified in <i>Safety</i> precautions. The customer is responsible for providing the necessary instructions to the persons concerned.
NOTE 	All dimensions in this document are expressed in millimeters.







**1.2 Safety precautions**

**1.2.1 General safety precaution**

1.2.1.1 Transport

 DANGER	Be aware of the weight and take care when transporting the system. For more information, please refer to 3. <i>Transportation handling and installation.</i>
---	--

1.2.1.2 General

 DANGER	Be sure that all power sources and other cables to the unit are disconnected before working on the product.
 DANGER	Only qualified personnel (trained by Epson and with professional experience) are authorized to work on this device.
 DANGER	Do not access the housing of the system controls. Serious injury or death could result from electric shock. Only authorized personnel from Epson are allowed to access this part of the system for maintenance or for repair.
 DANGER	Do not plug or unplug cables of the system unless it is switched off.
 DANGER	Never modify the product. Unauthorized modification may cause the product to malfunction, resulting in injury, electric shock, fire, etc.
 DANGER	Turn off the power to the product in the event of power failure. Failure to do so may cause the product to suddenly start moving when the power is restored.
 DANGER	Do not use the product in a place where it may come in contact with water or oil droplets.

## 1.2.1.3 Disposal

When the product becomes no longer usable or necessary, dispose of it properly as industrial waste.

 <b>WARNING</b>	Observe the valid legal regulations for appropriate disposal protecting environment.
---	--

## 1.2.2 Danger

## 1.2.2.1 Safety equipment for operators

For safety reasons operators must wear protective eyewear when using the backlight.

<b>NOTE</b> 	It is the customer's responsibility to install warning signs informing that anyone working around the part feeder must wear safety equipment.
--	---

## 1.2.2.2 Specific danger

  Backlight

The part feeder has an integrated Backlight that uses LEDs (Light Emitting Diodes). These LEDs emit visible or non-visible radiation depending on the color of the Backlight. LEDs illumination can create discomfort, cornea, retinal and lens damage.

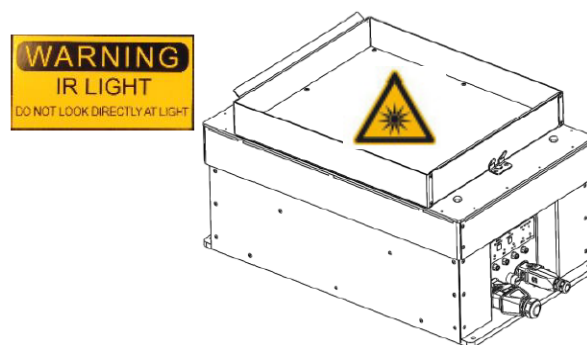

Figure 1-1: Specific warnings

The LEDs used are class 0 according to the norm EN 62471. It is the responsibility of customers to document their own application and instruct employees on procedures to limit exposure to LED radiation. The following prevention agent can be suggested:

- A Interpose, insofar as the job allows, a high pass filter at  $x$  nm depending on the color (see 2.5.2) under a fixed or adjustable connection between the source and the employee.
- B When the implementation of the foregoing is not possible, provide workers with goggles or face shield suitable for blocking radiation beyond 700nm.
- C Prohibit or limit as much as possible direct access to the source (exposure in the axis of radiation).
- D Establish a security perimeter to prevent operators from approaching the source at distances beyond the nominal ocular hazard recommended by the manufacturer.

### 1.3 Warranty information

---

E In all cases, ensure that the means used properly mitigate exposure variables (characteristics of screens or goggles to choose based on wavelength which operators are exposed).



#### Sound level

The sound level of the part feeder during intensive use without components in the platform is less than 72 dB(A). Depending on the components distributed in the platform, the sound level may be higher. In this case, it is the customer's or integrator's responsibility to implement the necessary measures to meet the safety requirements for operators.

### 1.3 Warranty information

You will find all the Epson warranty information (duration, scope of warranty ...) on the general conditions of sale.

## 2. Description

### 2.1 First glimpse of product

The Parts Feeder is composed of a platform capable of vibrating in 3 orthogonal directions in order to optimally distribute the components in the platform.

The vibrations of the Parts Feeder will be configured according to the type of components in order to guarantee an ideal process. The typical size of components that can be distributed in the platform ranges from 15 mm to 60 mm for IF-380 and from 30 mm to 150 mm for IF-530.

It consists of:

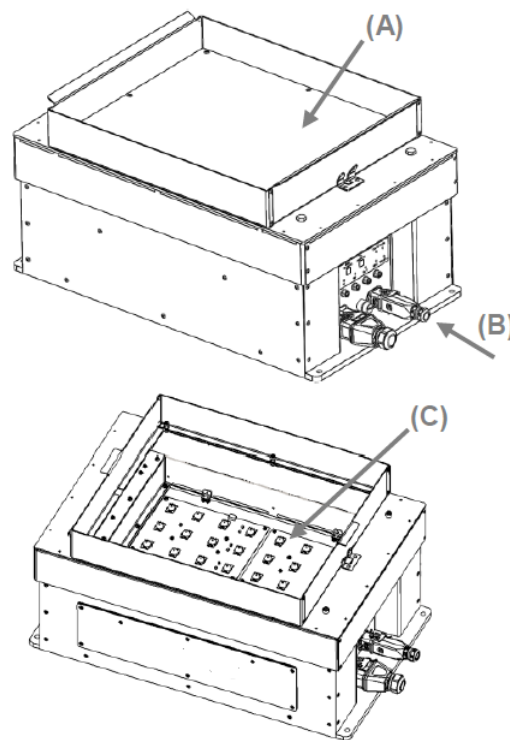

Figure 2-1: IF System overview

- (A) 3D vibrating platform
- (B) Electrical interfaces (communication, power supply, I/Os...)
- (C) An integrated backlight (optional) that allows an easy recognition of the parts from a camera placed above



For more information on electrical interfaces , refer to 2.4. *Electrical interfaces*.



For more information on how to remove or change the platform, refer to 4.2.2. *Remove the platform module*.

## 2.2 General characteristics



For more information on the backlight color and the procedure to exchange the backlight, refer to 4.3.1 *Exchanging / installing the backlight*.

## 2.2 General characteristics



WARNING

Do not use the product outside the specifications.  
In cases of non-conformity, the product warranty will be void.

### 2.2.1 Technical features

	IF-380	IF-530
Typical part size	length of side: 15 mm to 60 mm	length of side: 30 mm to 150mm
Integrated high power LED backlight	White	White
Interchangeable backlight color	(green, red, blue, white, Infrared) Please refer to 2.5.2 <i>Backlight</i> for more information.	(green, red, blue, white, Infrared) Please refer to 2.5.2 <i>Backlight</i> for more information.
Vibration frequency configurable	20 to 30 Hz	20 to 28 Hz
Maximum weight on the platformZ (components)	1.5 kg	2 kg
Digital Output for hoppers	2	2
Digital Input	2	2
Analog Output	2	2
RoHS	✓	✓

Before using parts, actually supply the parts to the feeder, move the feeder, will the parts be dispersed and move, and will the overlapping parts disentangle, etc.?

Parts that do not disperse and do not move and do not disentangle are not suitable for feeders.



## 2.2.2 Overall dimensions

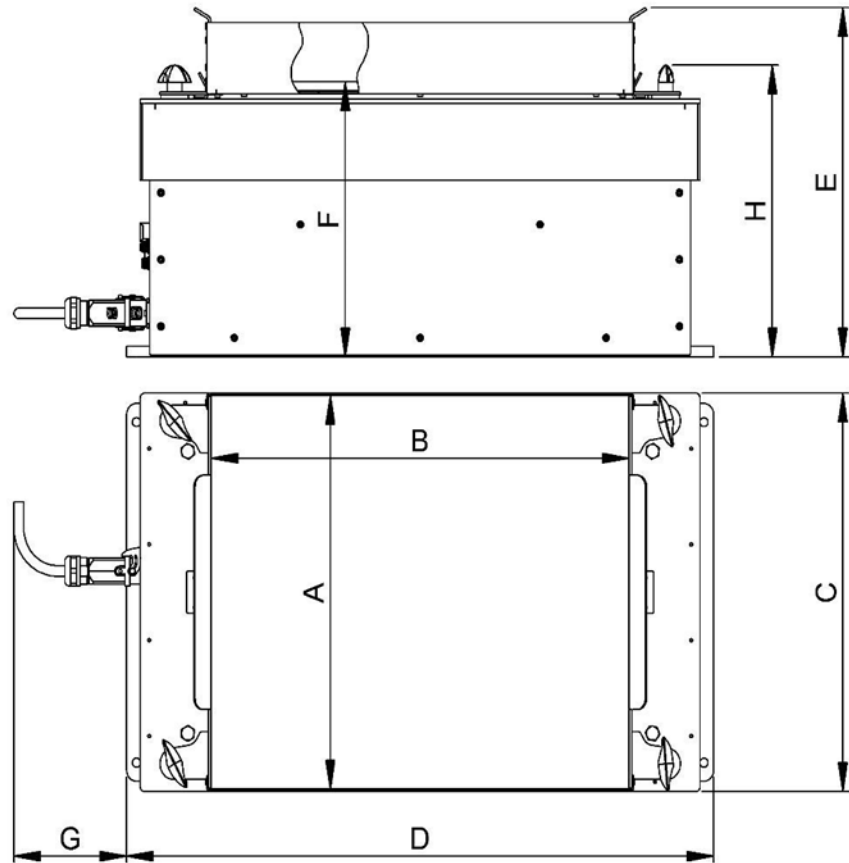

Figure 2-2: Overall dimensions

Characteristic		IF-380	IF-530
Footprint	C	257 mm	374 mm
	D	498.5 mm	600 mm
	G	147 mm	115 mm
Size of vibration platform	A	254 mm	370 mm
	B	325 mm	427 mm
	E ± low frame travel	308 ± 6 mm	328 ± 8 mm
	E ± high frame travel	333 ± 6 mm	360 ± 8 mm
	F (rest position)	245 mm	258.5 mm
	H	261 mm	274 mm
Weight with platform and backlight		20 kg	31 kg

2.2.3 Visual signals

The LEDs mounted on the unit give important information on the status:

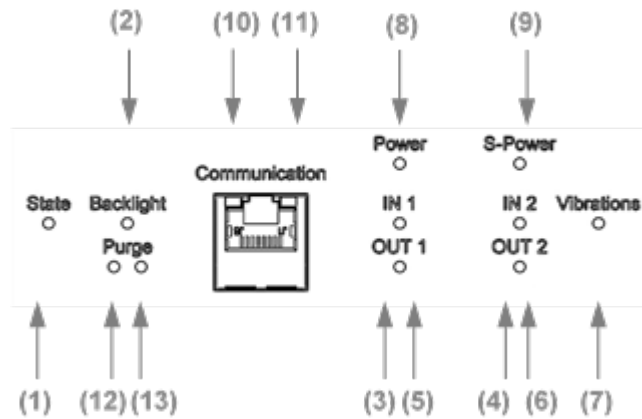

Figure 2-3: Operation Indicator LEDs

LED	State	Color	Meaning
1	Blinking Time on: 100ms	green	System in standby
	Blinking Time on: 900ms	green	System in service
2	On	green	24 V on backlight synchronization
3	On	green	24 V on input 1
4	On	green	24 V on input 2
5	On	yellow	24 V on output 1
6	On	yellow	24 V on output 2
7	On	green	Platform vibrating
8	On	green	24 V on power input
9	On	green	24 V on S-power input
10	On	green	Connection detection
11	Blinking	yellow	Communication in progress
12	On	green	24 V purge input
13	On	green	24 V purge input

### 2.2.4 Maximum permissible external force on the platform

The maximum permissible external force on a point of the platform (for example, with the gripper) is:

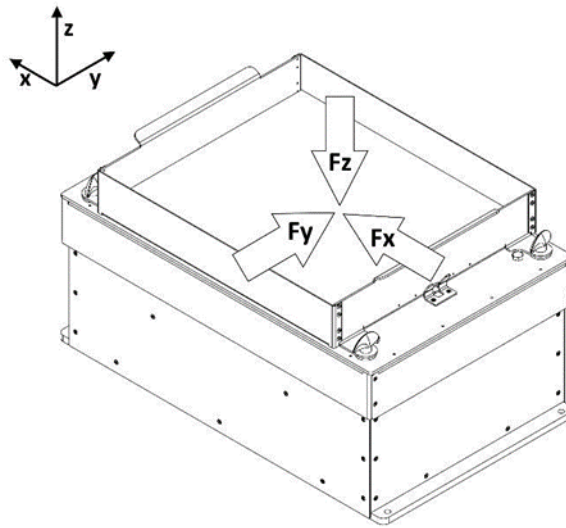

Figure 2-4: Maximum external force

$$F_x = 10 \text{ N}$$

$$F_y = 10 \text{ N}$$

$$F_z = 30 \text{ N}$$



Note that the shock/impact of the gripper may damage the surface of the platform.

### 2.2.5 Permissible platform weight

Characteristic	IF-380	IF-530
Maximum weight of the frame + platform assembly (without components)	4 kg	5 kg
Maximum weight of components (in addition to the maximum weight of the frame + platform assembly)	1.5 kg	2 kg

2.2.6 Maximum plate displacement

	IF-380	IF-530
Maximum displacement x	± 8 mm	± 8 mm
Maximum displacement y	± 10 mm	± 10 mm
Maximum displacement z	± 6 mm	± 8 mm

2.2.7 Plate Z repeatability

	IF-380	IF-530
Plate Z repeatability	≤ ± 0.4mm	≤ ± 0.3mm

2.2.8 Work surface

The surface corresponds to the size of the illustrated platform:

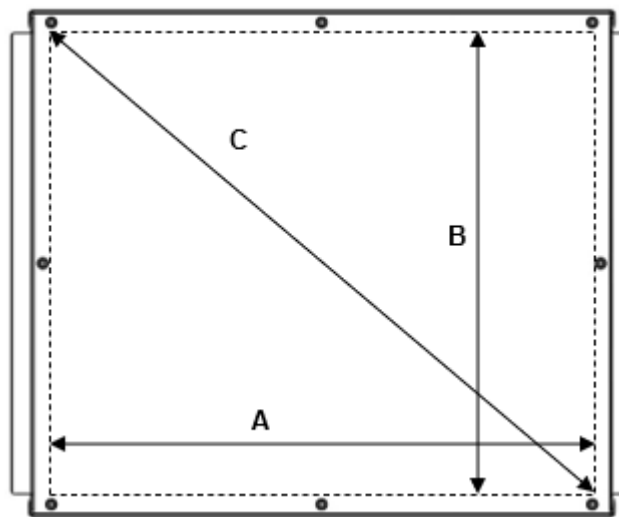

Figure 2-5: Work surface

	IF-380	IF-530
A	304 mm	403 mm
B	233 mm	347 mm
C	380 mm	530 mm

## 2.3 Electrical interfaces

### 2.3.1 Overview

The IF-380 and IF-530 are standalone modules with their own controllers. The electrical interfaces are located on the rear panel of the product:

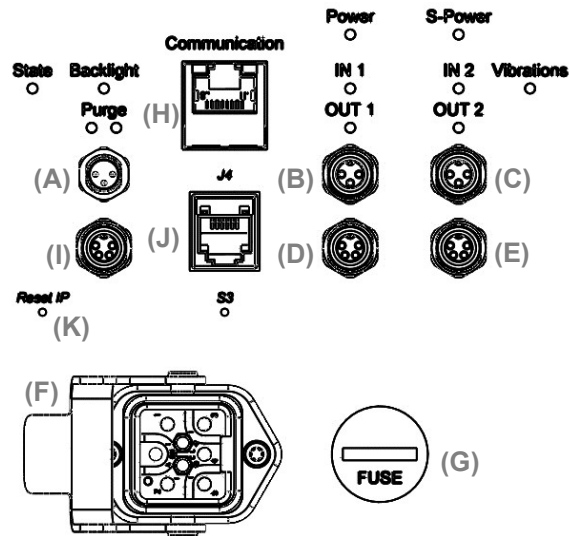



Figure 2-6: Electrical interfaces

- A Backlight synchronization
- B Digital input 1
- C Digital input 2
- D Digital and analog output 1 for hopper
- E Digital and analog output 2 for hopper
- F Power connection
- G Fuse
- H Ethernet connection (RJ45)
- I Purge connector
- J Programming connection (RJ12)
- K Reset IP address

2.3.2 Power connection

 <b>WARNING</b>	<ul style="list-style-type: none"> <li>- Before supplying power to the part feeder, check that the distribution voltage is the same as the nominal voltage.</li> <li>- Never disconnect the power cables when the unit is on. Always turn the machine off and then cut the power.</li> <li>- Use PELV (protected extra-low voltage) nominal voltage.</li> <li>- Unplug the main power plug when plugging / unplugging the cord.</li> <li>- Always connect the GROUND pin to the supply via the power cable.</li> </ul>
---	--

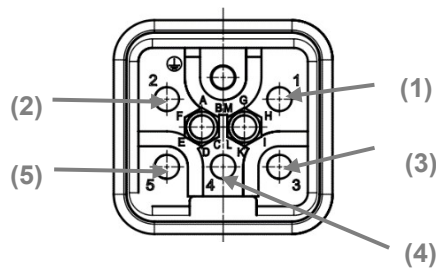



Figure 2-7: Power connection

Pin	Signal description	Cable
(1)	24V S-Power	1
(2)	0V GND S	2
(3)	24 V Power	3
(4)	0 V GND	4
(5)	Ground	PE

Connector type (on feeder side): Harting 09 12 005 3004

	IF-380	IF-530
Voltage	+24VDC ± 5%	+24VDC ± 5%
Consumption	4 A	6 A
S-power consumption	16 A	14 A

<b>NOTE</b> 	<p>Use a 20 A supply with a current reserve of 150% for 3 seconds                      The following power supplies have been tested:</p> <ul style="list-style-type: none"> <li>- PULS QS20.241</li> <li>- SIEMENS 6EP1336-3BA10</li> </ul>
--	--

<b>NOTE</b> 	<p>S-Power is the safety power for the backlight and actuators.                      Switching off this safety power ensures that the backlight stays OFF (e.g. to prevent against the risk of exposure to IR). Switching off this safety power deactivates the digital hopper outputs and the digital purge output.</p>
--	--

The following connection schematic shows the methods to connect to the feeder depending on if your application requires an external relay to ensure that the backlight is safely switched off or not. In any case, both “Power” and “S-Power” have to be supplied for using the backlight.

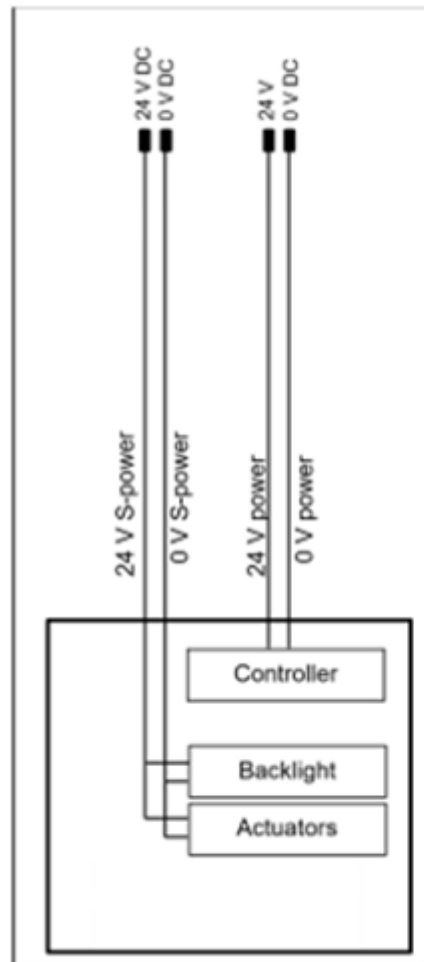

Figure 2-8:  
Power connection without safety relay

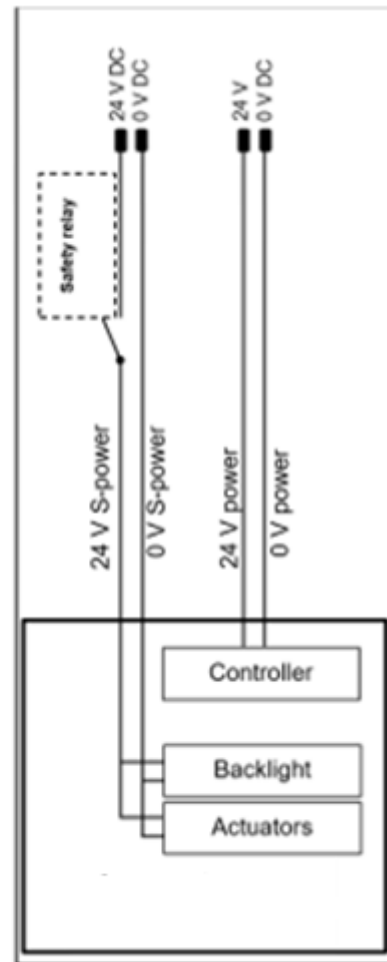



Figure 2-9:  
Power connection with safety relay

<p>NOTE</p> 	<p>Both Power and S-Power can be connected to a single power supply or to two different power supplies.</p> <p>The 0 V-GND and Earth signals of the two supplies are connected inside the feeder.</p>
---	---

2.3.3 Fuse

 <b>DANGER</b>	<p>Switch off the system and disconnect the power supply before opening the fuse holder.</p>
--	--

Time-delay fuse – 16 A

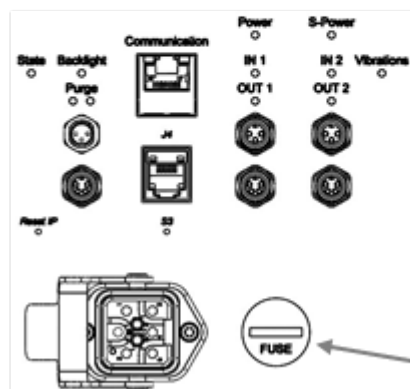
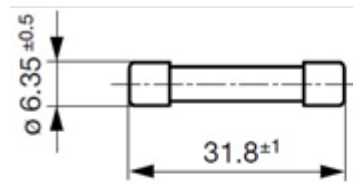

Figure 2-10: Fuse

2.3.4 Communication

The communication with the IF-380 & IF-530 is established by a standard Ethernet communication via RJ45 port.

Characteristic	Value
Default IP address	192.168.0.64
Default subnet mask	255.255.255.0
Port	4001
MAC address	Can be read by ARP request



For more information on the procedure to restore the default IP address, please refer to 4.3.2 *Recover IP address using default IP address.*



### 2.3.5 Digital output for hoppers 1 and 2

A standard M8 four-pins male cable enables transmission of the digital output signal to hopper. It must be connected as follows:



Figure 2-11: Digital output for hoppers

Pin	Signal description	Hopper
(1)	-	-
(2)	-	
(3)	0V GND	Digital Output 1
(4)	+24VDC	

Connector type (on feeder side): M8, 4P, female

### 2.3.6 Purge Connector

A standard M8 four-pin male cable is used to transmit the signals with the purge system.:



Figure 2-12: Purge Connector

Pin	Signal description
(1)	24 VDC
(2)	Digital input 24 VDC
(3)	0V GND
(4)	Digital output +24VDC 500 mA

Connector type (on feeder side): M8, 4P, female

## 2.4 Mechanical Interfaces

### 2.4.1 Mounting the IF-380 & IF-530

To guarantee correct operation, the IF-380 and the IF-530 must be securely attached (with four M8 screws) to a solid support, ideally a steel plate secured to a frame.

The total weight of the plate and frame, if they are not attached to the floor, should be at least 200 kg (IF-380) and 250 kg (IF-530) in order to dampen some of the vibrations.

<p>NOTE</p> 	<p>Depending on the weight of the system to which the feeder is secured, the vibrations of the feeder can interfere with the sensitive surrounding processes. These interferences can be reduced using a solid support or by securing it to the floor.</p>
---	--

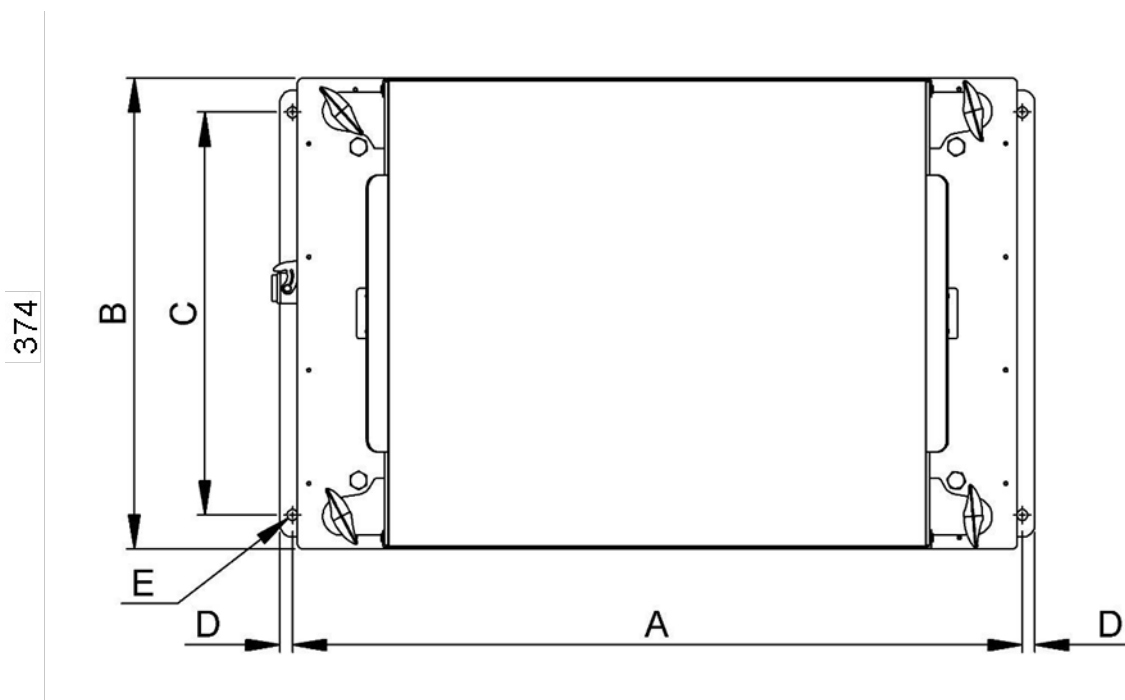

Figure 2-13: Mounting

	IF-380	IF-530
A	480 mm	580 mm
B	257 mm	374 mm
C	200 mm	320 mm
D	9.25 mm	10 mm
E	ø 8.5mm	ø 8.5mm

## 2.5 Accessories and Optional modules

### 2.5.1 Platform

The flat platform can be used for a large variety of components, mainly components with a flat surface allowing a stable resting position.

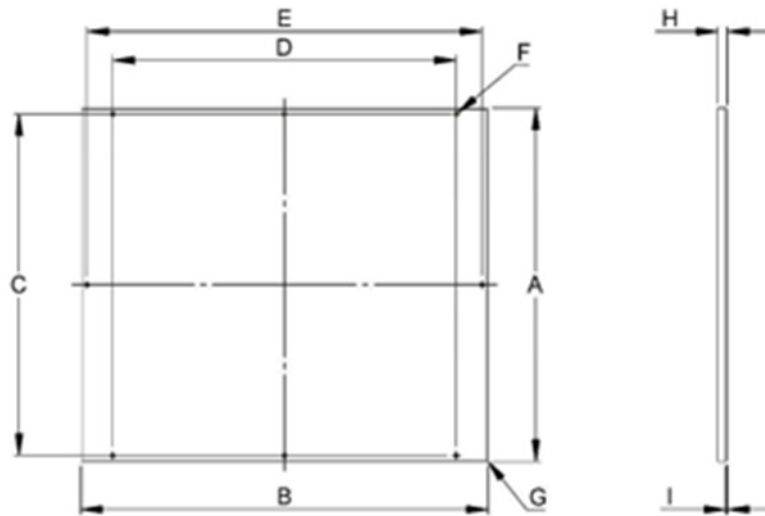

Figure 2-14: Dimensions of platform

	IF-380	IF-530
A	252.8 ± 0.5 mm	369.8 ± 0.5 mm
B	323.8 ± 0.5 mm	426.8 ± 0.5 mm
C	240 ± 0.15 mm	357 ± 0.15 mm
D	260 ± 0.15 mm	360 ± 0.15 mm
E	311 ± 0.15 mm	412 ± 0.2 mm
F	M3×6 mm	M3×6 mm
G	0.5×45° (4×)	0.5×45° (4×)
H	10 mm	10 mm
I	1.5×45° (4×)	1.5×45° (4×)

## 2.5.2 Backlight

The following backlights are available:

Backlight color	Wavelength
Blue	465 nm
Green	550 nm
Infrared	850 nm
Red	645 nm
White	6500 K

The backlight will be installed when it is ordered at the same time as the feeder.

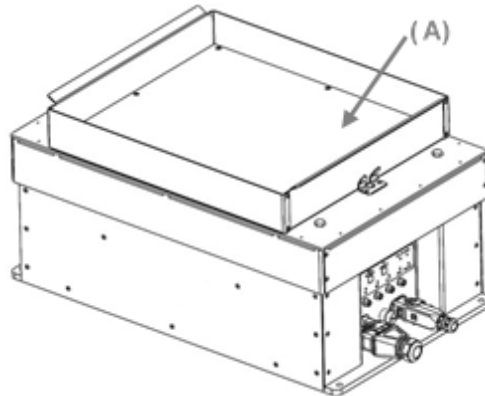

**DANGER:**

Infrared light (IR) is invisible to human eyes. NEVER use the infrared light without the platform (A). When the platform (A) is attached to the part feeder, the system does not pose a risk for the operator.

### 2.5.3 Hopper

An optional hopper is available in the 10 or 15 liters versions.

The stainless-steel type 1.4301 hoppers withstand a maximum filling load of 15 kg

Available products:

Product	Part Code
10 liter hopper	Please contact the supplier of your region.
15 liter hopper	

Each product comprises:

- The hopper
- The linear feeder
- The control unit
- The cable set

#### 2.5.3.1 Wiring diagram

The hopper is supplied with the controller and cables ready to be installed. Depending on the model chosen, the hopper should be supplied with

- 115V (+10%/–15%), 50Hz, 6A
- 115V (+10%/–15%), 60Hz, 6A
- 230V (+10%/–15%), 50Hz, 6A
- 230V (+10%/–15%), 60Hz, 6A

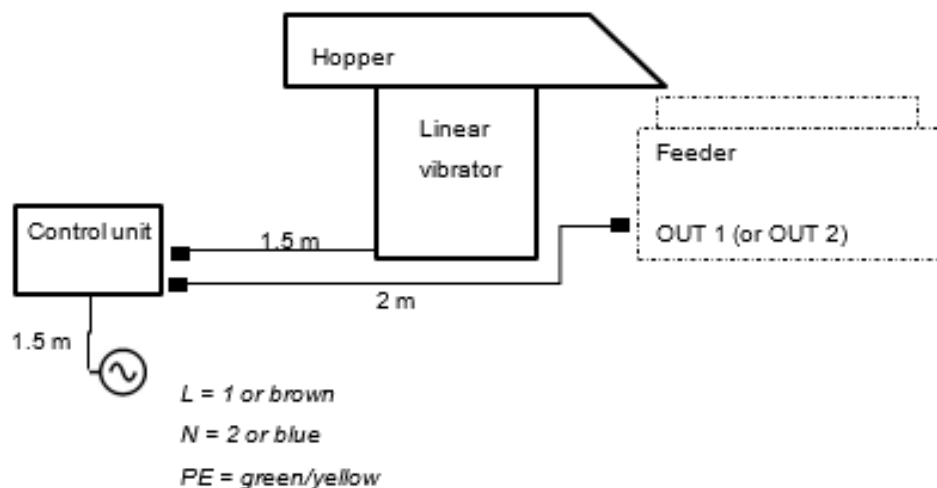

Figure 2-15: Wiring

## 2.5 Accessories and Optional modules

### 2.5.3.2 Control unit

The vibration intensity of the hopper can be adjusted with the potentiometer.



Place the control unit in a position that allows access to the potentiometer.

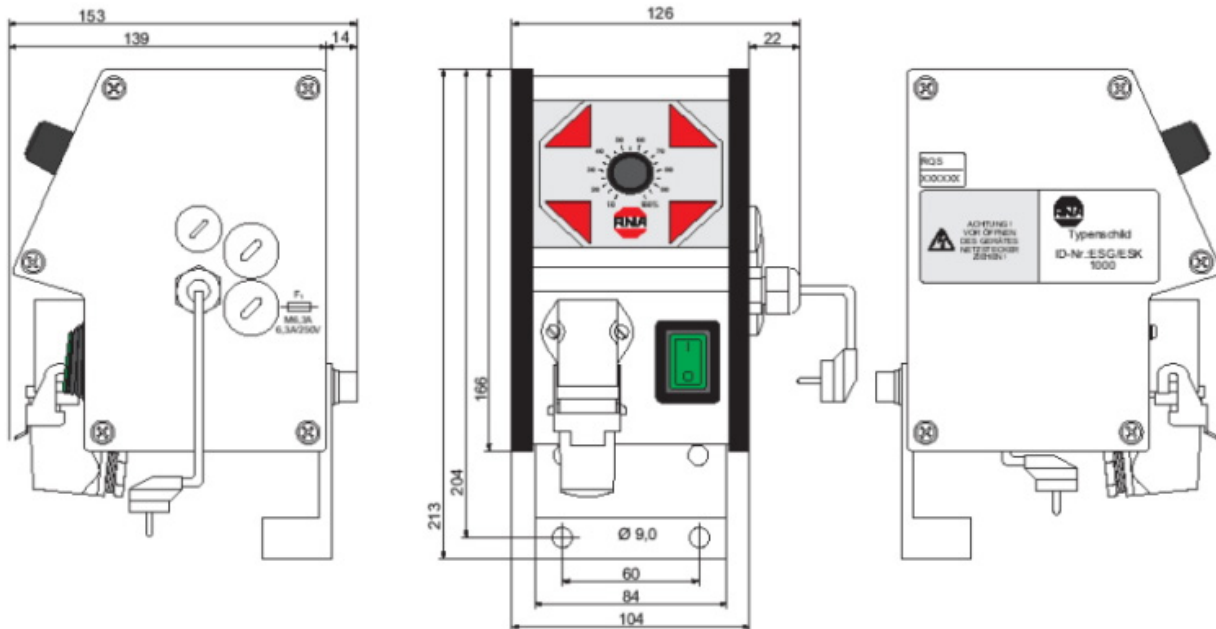

2.5.3.3 10L hopper mechanical interface for IF-380  
with hopper mounting kit (as an option depending on product list):

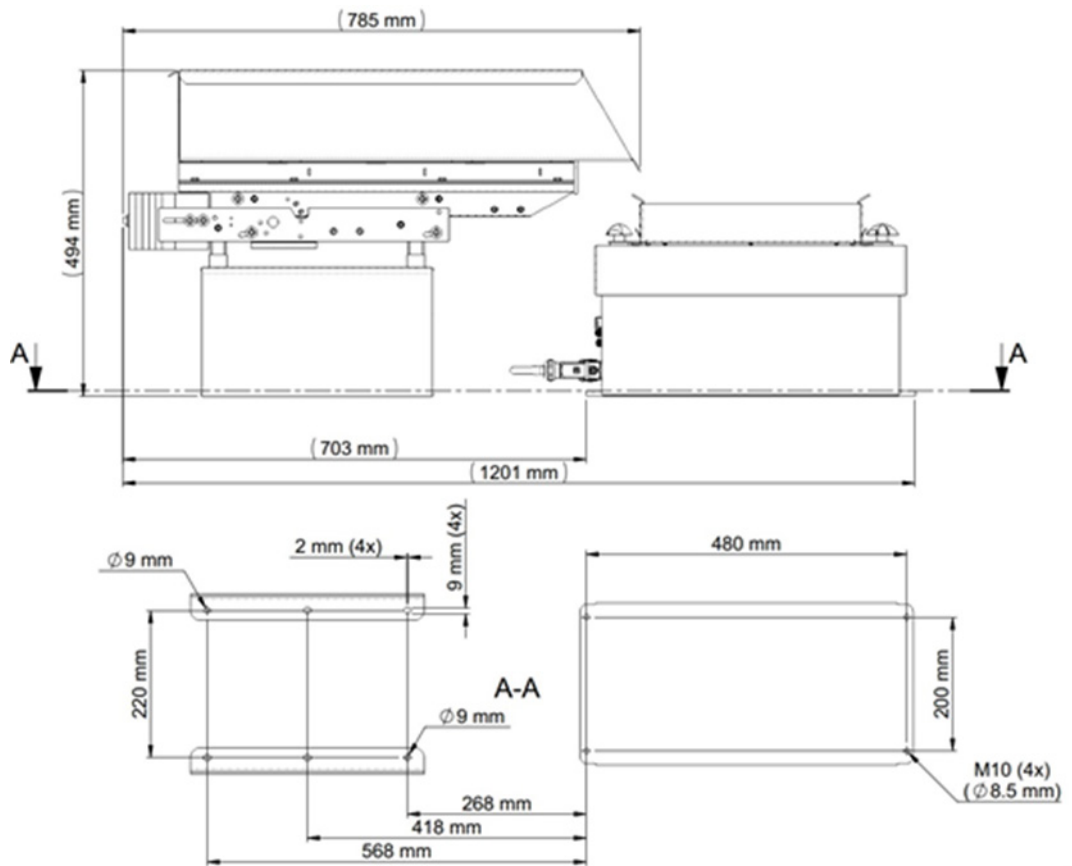

Without hopper mounting kit:

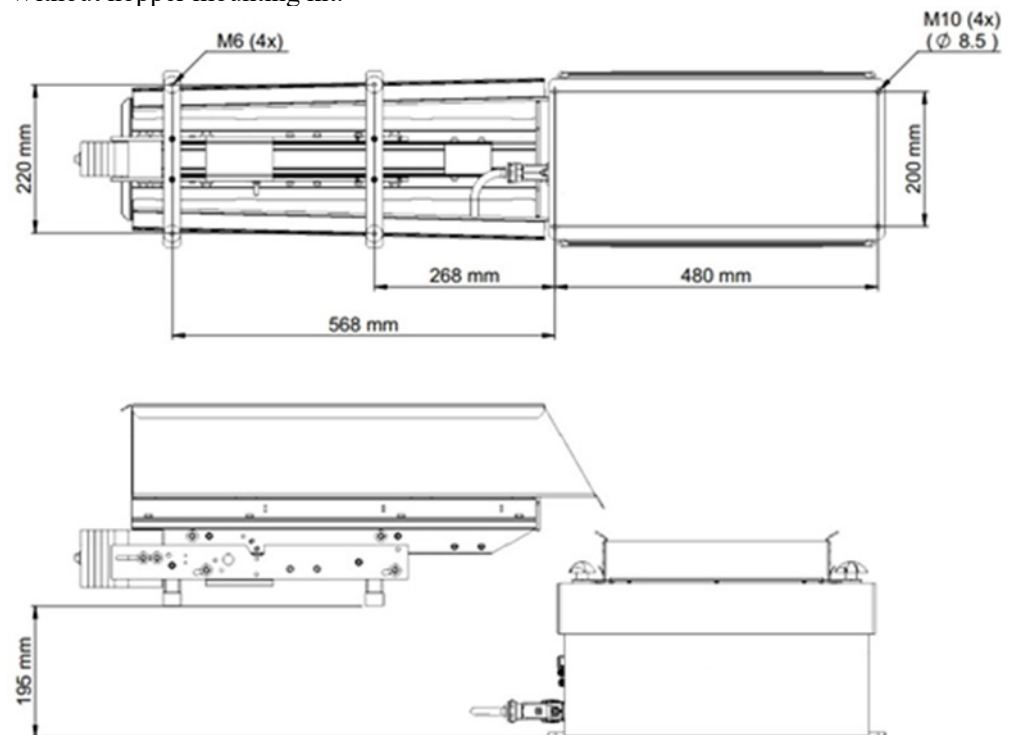

## 2.5 Accessories and Optional modules

### 2.5.3.4 15L hopper mechanical interface for IF-530

With hopper mounting kit (as an option depending on product list):

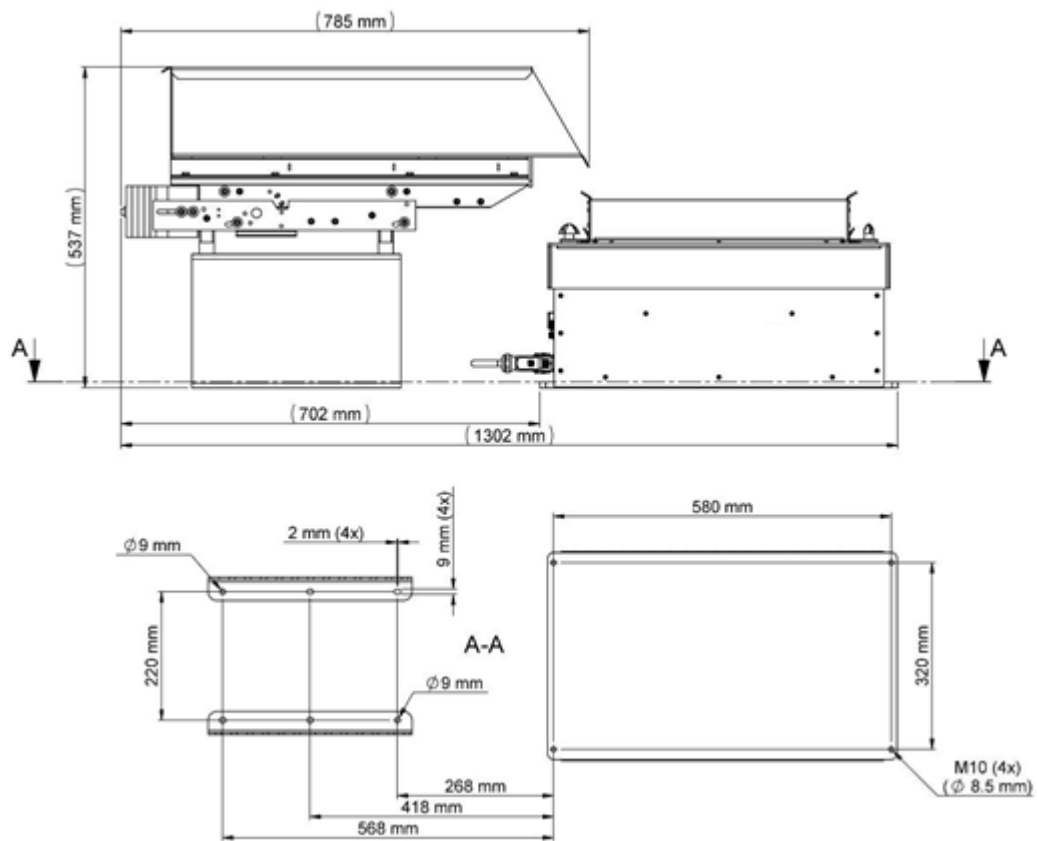

Without hopper mounting kit:

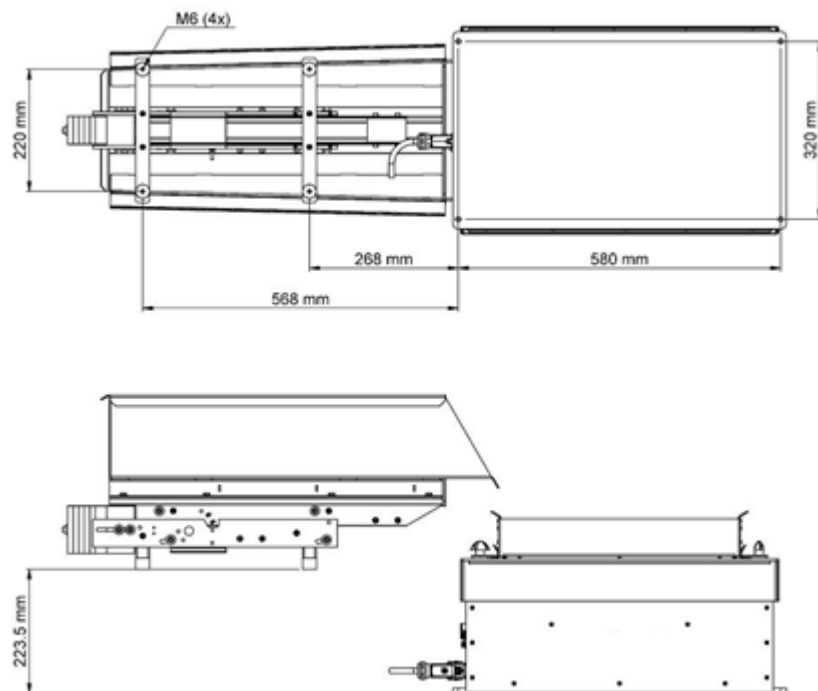



## 3. Transportation, handling, and installation

### 3.1 Packaging of the product, transportation and handling

The transportation of the product must be made in accordance with the specific terms indicated on the package (top, bottom, fragile, etc.). In addition, pay particular attention to the following points:

 <b>WARNING</b>	<ul style="list-style-type: none"> <li>- Be aware of the weight and take care when transporting the system.</li> <li>- Always hold the system firmly with two hands.</li> <li>- The operator should not carry heavy shipping boxes by himself.</li> <li>- If the shipping box is to be left standing, it should be in a horizontal position.</li> <li>- Do not climb on the shipping box.</li> <li>- Do not place heavy objects, on top of the shipping box.</li> </ul>
---	---

The IF-380 is shipped in a cardboard box. The IF-530 is shipped on a pallet. The dimensions are as follows:

	IF-380	IF-530
Dimensions	680400×450 mm	800×500×550 mm
Gross weight	28 kg	50 kg

Table 3-1: gross weight and dimensions of the product when packaged

### 3.2 Unpacking instructions

<b>NOTE</b> 	<p>Do not remove the part feeder from its packaging until you are ready to install it.</p>
--	--

 <b>WARNING</b>	<p>Keep the packaging material and the shipment box in case of need for return.</p>
---	---

Locate the identification sticker at the back of the product and ensure that the product you have received is the appropriate one.

Important information is on this sticker; such as the power consumption rating and the type name and serial number that you will need for any kind of correspondence with Epson.

### 3.3 Installation and storage environment

 <p>WARNING</p>	<ul style="list-style-type: none"><li>- The feeder must be mounted on a smooth, flat and solid surface. Ensure that the IF-530 is not submitted to mounting flexure. Failure to do so will degrade feeder performance.</li><li>- Be careful not to get hands or feet caught and/or have equipment damaged by a fall of the feeder. When working, please wear protective equipment including safety shoes.</li></ul>
--	---

#### 3.3.1 Installation environment

The feeder can be used under the following conditions:

- Protection class is IP50 compliant
- Working temperature: +5°C to +40°C
- Humidity: 30% to 80% max. non-condensing

 <p>WARNING</p>	<p>Variations in humidity or temperature may affect the global performance of the part feeder.</p>
--	--

- Avoid extreme electromagnetic waves, ultraviolet rays and radiation.
- Avoid using the product in a place where the main unit or controller may be exposed to water or oil droplets.

 <p>WARNING</p>	<p>Do not use the product in an atmosphere of corrosive gases. Rust may form and reduce the structural strength of the product.</p>
--	---





#### 3.3.2 Storage environment

The storage environment should be similar to the operating environment. In addition, you should protect the part feeder against dust

## 4. Maintenance and component replacement

### 4.1 Safety precautions

#### 4.1.1 General safety precautions

 WARNING	There are no user serviceable parts inside the product. Contact the supplier of your region or your local supplier for maintenance. In cases of non conformity, the product guarantee will expire.
 DANGER	Do not operate the system when it is damaged. Please ensure before use that there are no visual defects.
 DANGER	Failure to observe the instructions may result in electrocution or serious injury due to electric shock.
 DANGER	Power down the system and unplug it from the mains before any kind of maintenance.
 DANGER	Do not pour water or any other liquids onto the product. Spraying water over the product, washing it with water or using it in water may cause the product to malfunction, resulting in injury, electric shock, fire, etc.

#### 4.1.2 Specific warnings

 WARNING	Be sure that the platform is unloaded before any kind of maintenance.
--	---

## 4.2 Maintenance

 <b>WARNING</b>	For any kind of maintenance, always use Epson products.
---	---

### 4.2.1 Periodic maintenance schedule

The IF-380 & IF-530 are virtually maintenance-free. However, simple inspections should be done at regular intervals to ensure optimum performances, and safety operating of your product.

	Item	Period	Reference
General	Cleaning of the machine	Weekly	
	Visual check of electrical harness	Year	
	Visual check and cleaning of the plate	Weekly	Section 4.2.4
	Replacing the ball joints	2 years or 4000 h of vibrations	Section 4.2.5
Specific process	It is the customer's responsibility to schedule the maintenance of his specific process	/	/
Backlight	Visual check	Month	

Table 4-1: Periodic maintenance schedule

<b>NOTE</b> 	The information given in "Table 4-1: Periodic maintenance schedule" is only a guideline. Maintenance and times must be modified in accordance with your particular system, its operating environment and the amount of usage.
--	---

### 4.2.2 Remove the platform module



DANGER

Be sure that the backlight is off before removing the platform module.

Step 1

Unscrew the 4 handle screws

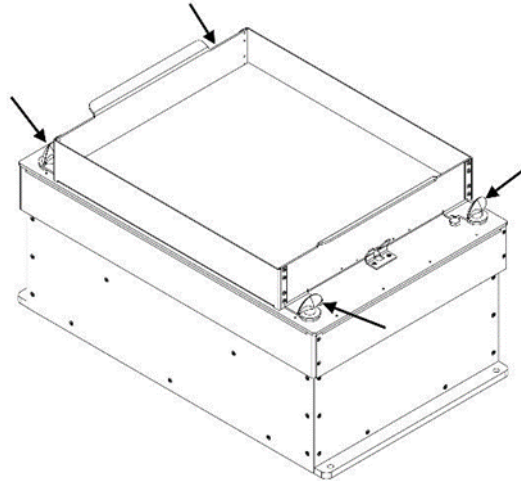

Step 2

Remove the platform assembly

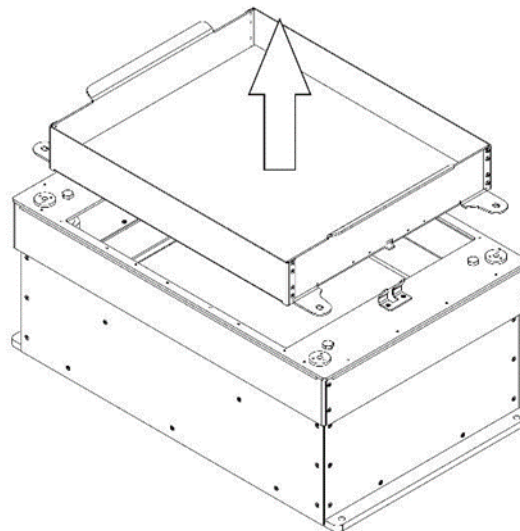

### Step 3

Unscrew the 8 screws and take the platform out of the frame

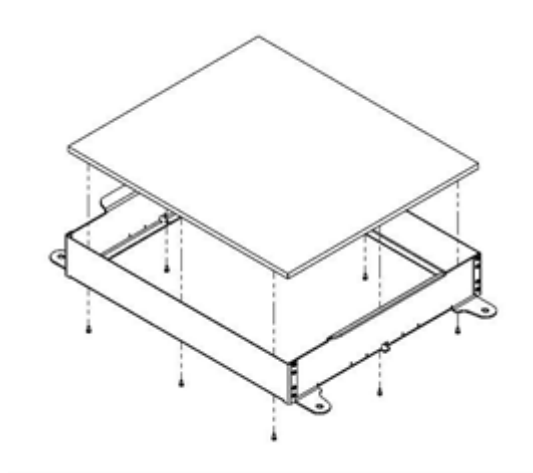

Figure 4-1: Remove the platform

### Step 4

Assembly: Position the platform in the frame (8 screws 0.8N·m).

Position the assembly on the part feeder. Tighten the 4 handle screws securely by hand

### 4.2.3 Control in purge configuration

#### Step 1

Completely unscrew the 8 screws (A) using a Torx 8 screwdriver and remove the flank (B)

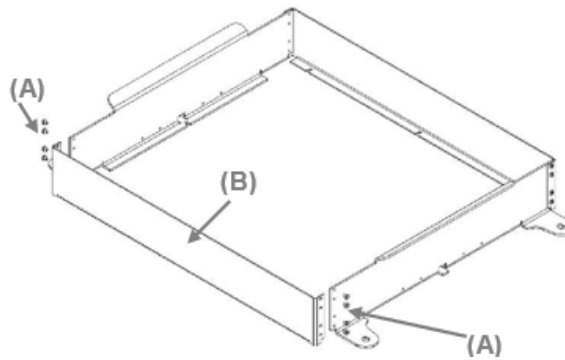

#### Step 2

Fit the adapter piece (C) and secure it using 4 screws (0.6 N·m)

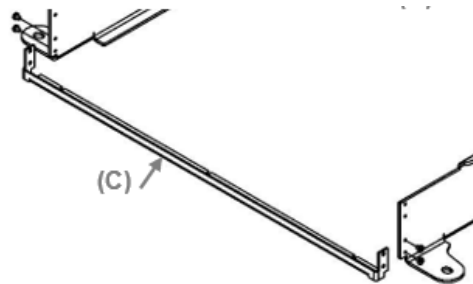

The part (C) is available as an option.

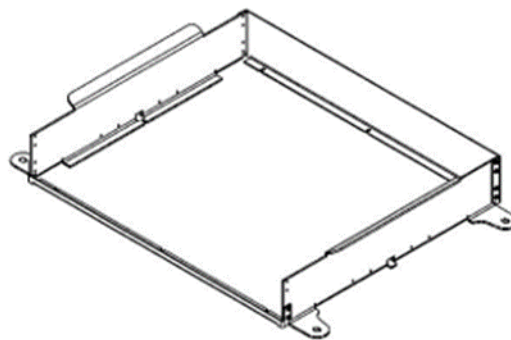

Option to attach a purge spout to the base of the part feeder using 4 screws (D) (0.6 N·m)

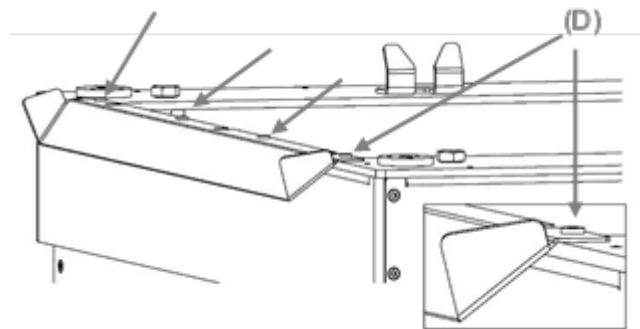

Figure 4-2: Platform in purge configuration

### 4.2.4 Checking and cleaning of the platform

Material needed:

- Lint-free cloth
- Isopropanol alcohol

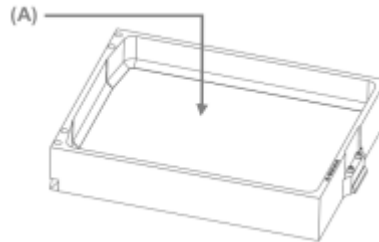

Figure 4-2: Platform

Step 1

Control the surface state of the platform (A) and be particularly careful of the following points:

- Dirt or spotted surface
- Oily or greasy surface



WARNING

If the surface is damaged so as to obstruct vision or the behavior of parts, its replacement must be preceded. For more information about maintenance parts, please contact the supplier of your region.

Step 2

Clean the surface of the platform.

### 4.2.5 Replacing the ball joints

Step 1

Remove the platform and completely unscrew the 4 nuts (A) whilst holding the hexagonal extension (B)

Use size 13 and 17 open-end wrenches

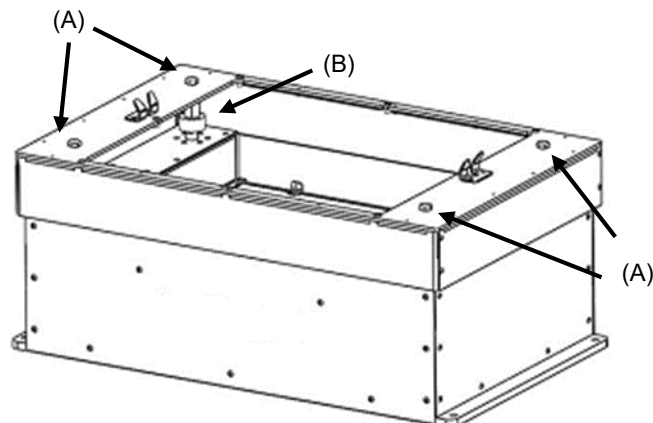



## Step 2

Remove the upper assembly (B)

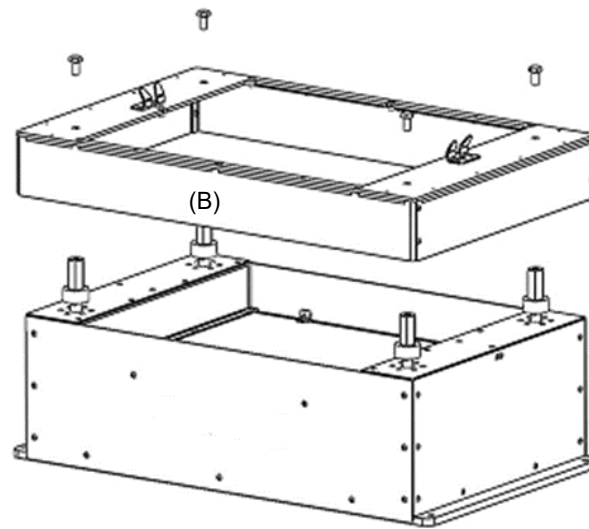

## Step 3

Hold the axis (C) with a size 10 open-end wrench whilst you loosen the ball joint (D)

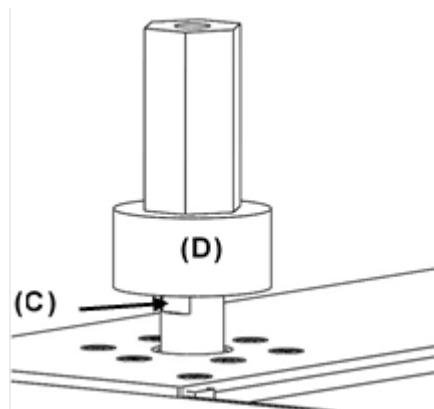

## Step 4

Apply a drop of adhesive (type: Loctite 243 or similar) to the outer thread of the new ball joint

Securely tighten the new ball joint (D) BY HAND (do not use a tool) (mounting bush + extension), while maintaining the axis (C) with a size 10 open-end wrench

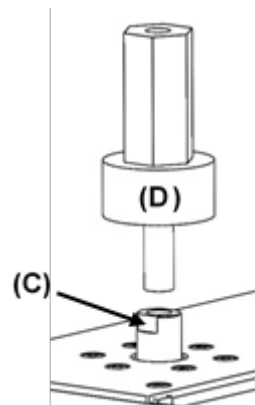

Step 5

Place the upper assembly (B) on the 4 ball joints and carefully align the holes opposite the threads

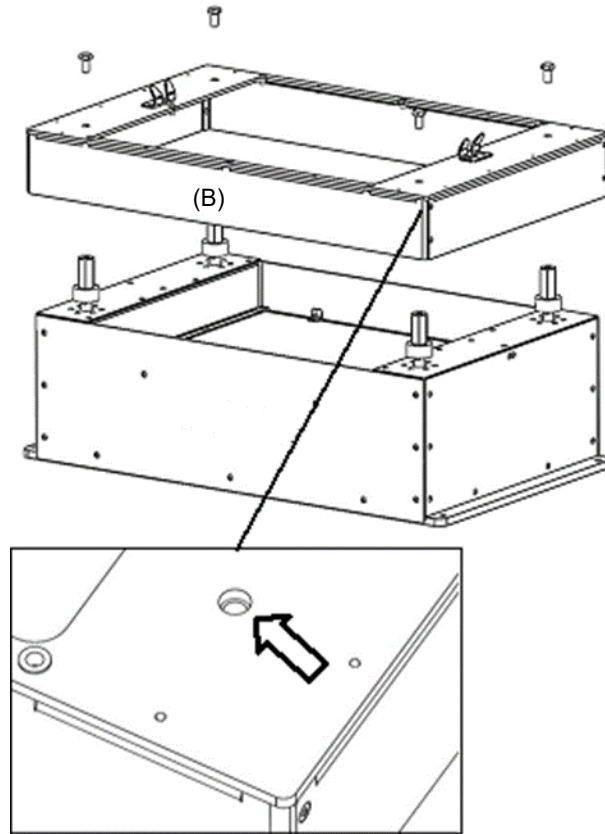

Step 6

Apply a drop of adhesive (type: Loctite 243 or similar) to the nuts  
Tighten (4.4 N·m) the four nuts WHILE HOLDING the hexagonal extension (H) with a size 17 open-end wrench

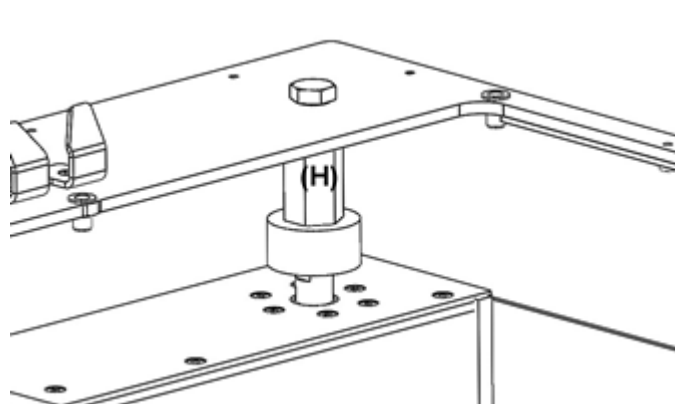

## 4.3 Component replacement

For a list of the components which can be replaced directly by the customer, please contact the supplier of your region. For any other repair, the product must be returned to the manufacturer.

 <b>WARNING</b>	<p>For any kind of replacement, always use Epson products.</p>
---	--

### 4.3.1 Exchanging / installing the backlight

 <b>DANGER</b>	<p>Be sure that all power sources and other cables to the unit are disconnected before changing the backlight.</p>
--	--

Material needed:

- New backlight assembly ordered from the supplier of your region. (Ask for the part code from the supplier.)
- Flat wrench size 5.5
- Torx key size 10

Step 1

Unscrew the 11 screws on both sides (A) and remove the two side covers. Use a Torx key size 10.

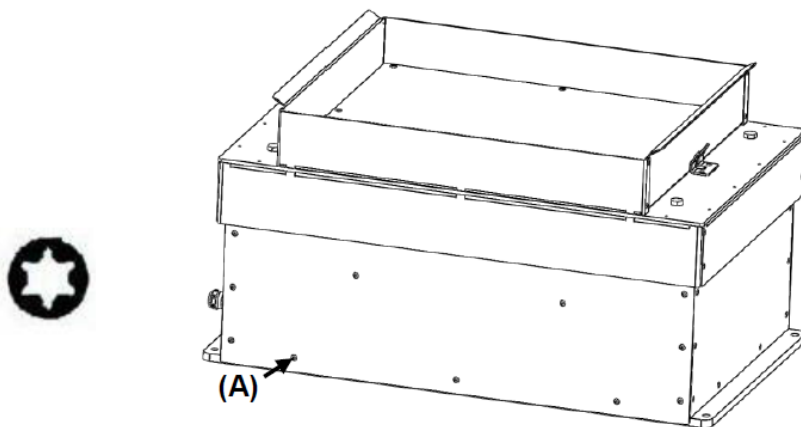

## 4.3 Component replacement

---

### Step 2

On both sides, unscrew the four bolts (B). Use a flat wrench size 5.5.

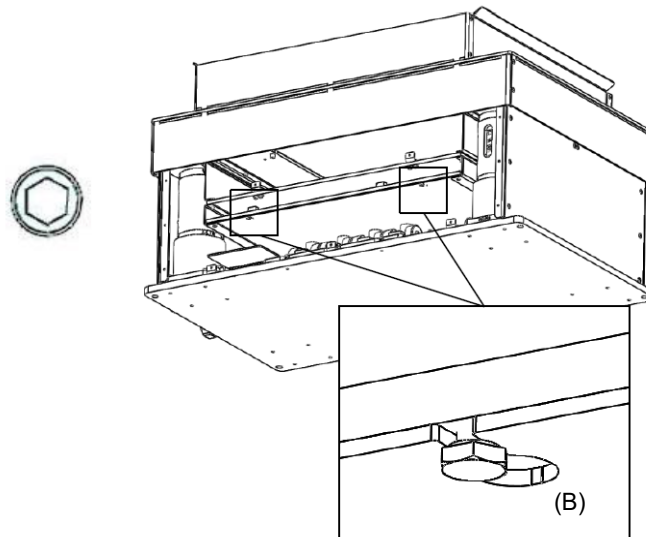

### Step 3

Carefully disconnect the connectors from the electronics.

Remove the old backlight assembly (D)

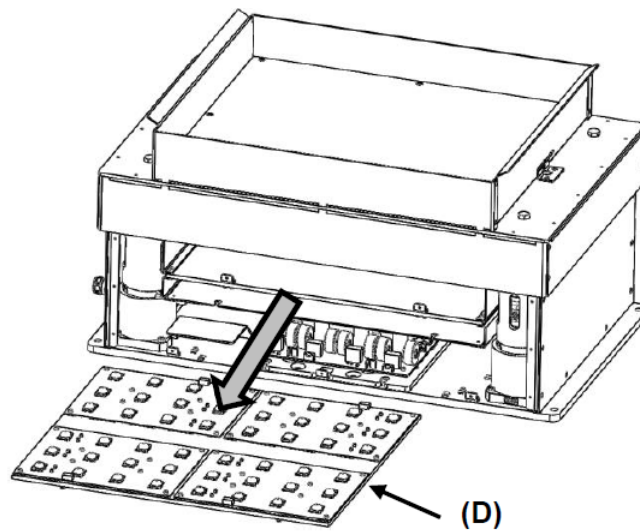

## Step 4

Replace the complete backlight assembly or only a backlight board by unscrewing the 8 screws (E) (it may be necessary to use a tool to detach the backlight print)



Use a torx key size 10

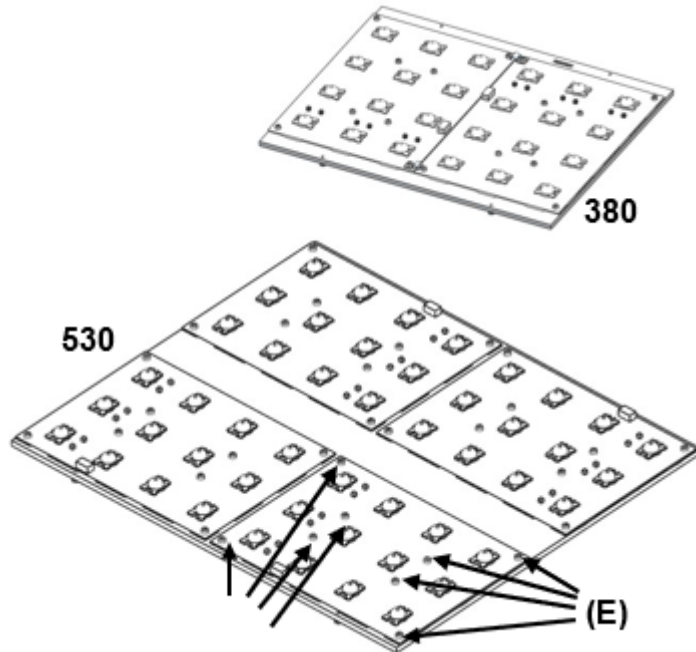

## Step 5

Replace the backlight boards respecting the position of the connector (F), and tighten the 8 screws (0.7 N·m)

Take care to remove the protective film on the underside of the backlight board



Use a torx key size 10

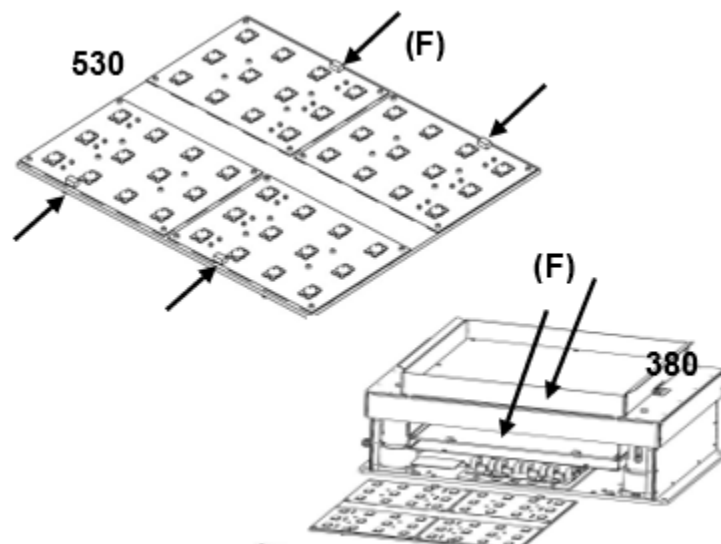

## 4.3 Component replacement

---

### Step 6

Insert the backlight assembly (G) and align it flush with the support.

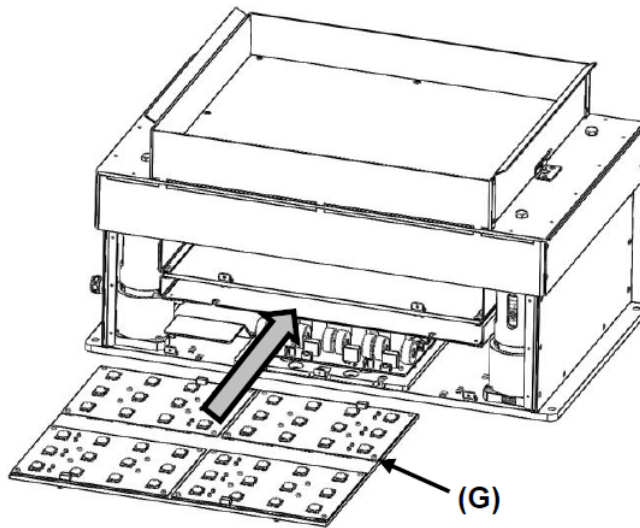

### Step 7

Tighten the four bolts (H).



Use a flat wrench size 5.5

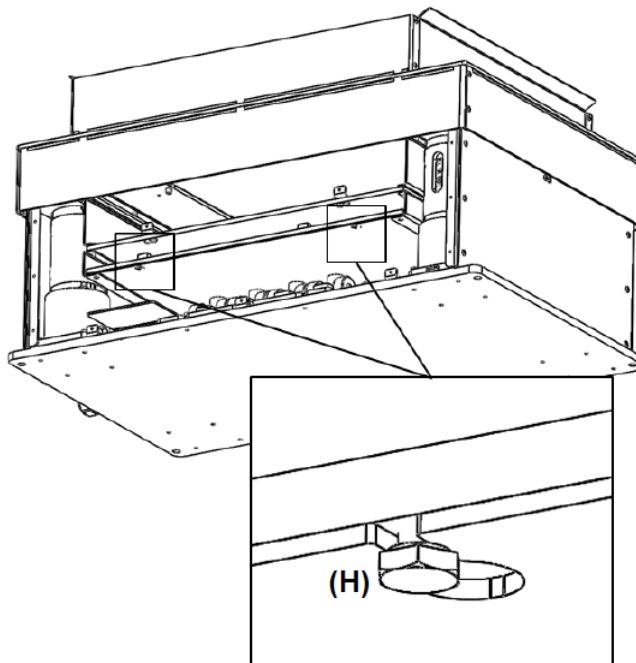

### Step 8

Connect the connectors to the electronics

## Step 9

Refit the covers (J) on both sides and tighten (1.3 N·m) the screws on both sides



Use a Torx key size 10 (0.8 N·m)

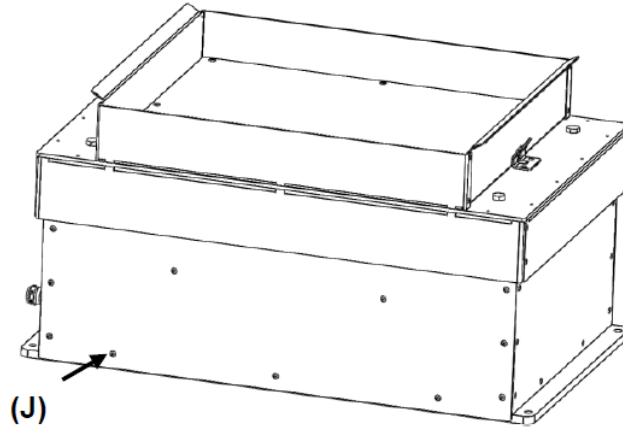

### 4.3.2 Recover IP address using default IP address

The following procedure explains how to reboot the feeder so that it uses the default IP address, subnet mask and TCP port number to be able to modify the IP address, subnet mask and TCP port number when they are unknown and cannot be found. Following this procedure, you are able to connect to the part feeder default parameters and then modify parameters as desired.

**Step 1**

Switch off the power or disconnect the power cable (A).

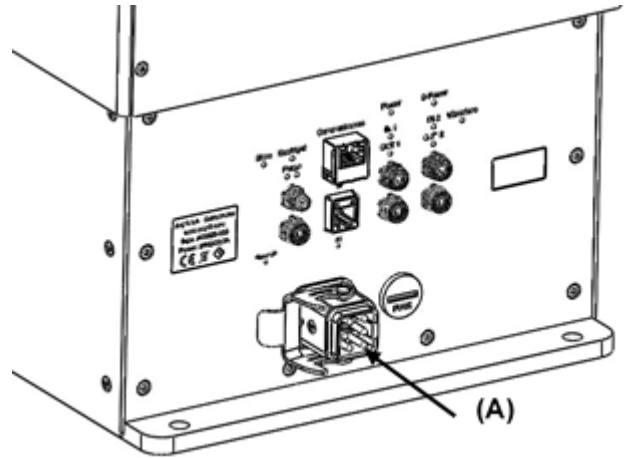

**Step 2**

Insert a tip in the “Reset IP” hole (B) and reconnect the power cable or switch on the part feeder.

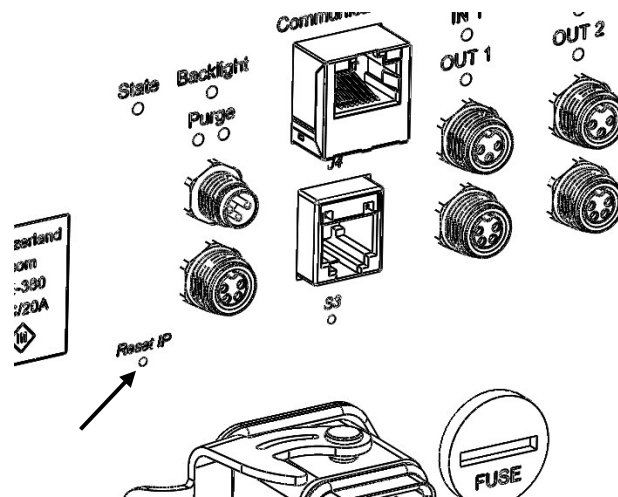

The part feeder will now use the following default parameters at startup:

- IP: 192.168.0.64
- SubnetMask: 255.255.255.0
- TCP Port: 4001

**Step 3**

Parameters in memory can now be modified by RC+  
For more details, refer to *software 2.1 System Settings*